Brushless Servo Amplifiers

ServoFlex-RES A Version

SFA-03A-RES
SFA-07A-RES

0101

Part Number 575-00021E

©MTS Systems Corporation 2001



2101 North Broadway

New Ulm, MN 56073

Telephone: 507-354-1616

Fax: 507-354-1611

TABLE OF CONTENTS

Application.....	1
Unpacking and Inspection.....	1
Warranty and Service.....	1
Service Under Warranty.....	2
Non-Warranty Service.....	2
General Provisions.....	2
Introduction.....	3
Features.....	3
Specifications.....	4
Mechanical Footprint.....	6
Feedback Wiring.....	7
Thermostat.....	7
Diagnostic Indicators.....	8
Configuration.....	9
Jumpers.....	10
TAC Polarity.....	10
JP1 = N.....	10
VELOCITY/TORQUE (current) Mode.....	10
JP2 = UP.....	10
Simulated Encoder Signals.....	12
I/O Wiring and Descriptions.....	13
Analog Input, Outputs and Adjustments.....	14
Input.....	14
Diagnostic Signals.....	15
TAC Gradient.....	15
Current Gradient.....	15
Analog Inputs (Specific Interface Requirements).....	16
AC Input and Internal Protection.....	17
Internal Protection.....	17
Grounding – Single Phase.....	18
Typical 220 VAC Single Phase.....	18
Step Down Transformer.....	18
Single Phase Amplifiers on Three Phase Power.....	19
Three Phase Line to Multiple Single Phase Amplifiers.....	20
Grounding – Three Phase.....	22
Typical WYE Secondary.....	22
Typical Delta Secondary.....	22
Delta Secondary.....	23
Power/Grounding Requirements.....	24
Stator Wiring.....	26
"-S" Separated Supply Option.....	27
Thermal Characteristics.....	28
Start-Up.....	29
Typical Wiring.....	30

SERVOFLEX AMPLIFIER

Application

This manual is designed to help you install the MaxPlus™ ServoFlex RES A Version amplifier.

Unpacking and Inspection

Carefully unpack the amplifier and inspect it for visible damage. Check items against the packing list. Report any missing or damaged items to your supplier.

Warranty and Service

The amplifier is warranted to be free from defects in workmanship and materials for a period of two years from the original shipment by MTS Automation.

During the warranty period, a defective amplifier unit will be repaired or replaced as outlined below.

Before requesting return authorization, please try to verify that the problem is within the amplifier, and not with external devices.

To arrange for repair or replacement, please contact:

MTS Automation Customer Service
(507) 354-1616
(800) 967-1785
Monday–Friday, 8:00–4:30 Central Time

- You must provide the model and serial number from the labels on the amplifier.
- You must provide an explanation as to why the unit is being returned.
- You will be issued a return authorization number which must be marked on the return shipment and on all correspondence.

Continued on next page

Warranty and Service (continued)

Service Under Warranty

- Return your defective unit, freight prepaid, and it will be repaired and returned within two weeks of receipt via regular UPS, freight prepaid.
- Upon request, a factory-repaired replacement unit will be sent via regular prepaid UPS, within 4 working days. Next day shipment for overnight delivery, freight collect, is available at an expediting charge of \$100. The defective unit is to be returned via regular UPS, freight prepaid, upon your receipt of the replacement.

Non-Warranty Service

- Return your defective unit, freight prepaid, and it will be repaired on a time and material basis and returned within three weeks of receipt.
- OR contact your local distributor or MTS Automation Customer Service for a factory-repaired exchange unit, which is available at a flat rate price, assuming the defective unit is in repairable condition and is returned freight prepaid. Next day shipment for overnight delivery, freight collect, is available at an expediting charge of \$100.

General Provisions

Except as specifically modified by this warranty statement, all MTS Automation Conditions of Sale and Warranty shall apply.

Introduction

The ServoFlex amplifier is high performance, reliable, and efficient. The amplifier is designed to be used with high performance brushless servo motors. Extreme care has been taken to assure robust operation. Design consideration for electrical transients have been implemented on the ac inputs and all I/O lines. The amplifier operates over an ac voltage range of 80 to 260 Vac from 45 to 65 Hz. The motor feedback device is a resolver to assure normal operation at elevated motor temperatures of 115° C for the case, and 155° C for the motor windings. The resolver allows for both position and velocity feedback. The motor is further protected by a thermal shutdown thermostat in the motor windings. The amplifier power switching devices are state of the art IGBT modules. The logic supply is a switch mode design reducing undesired heat. LED indicators for diagnostics are provided. Encoder simulated TTL compatible differential quadrature outputs plus an index output are provided for external pulse or position control. The amplifier has in-rush current protection to allow for normal turn ON. This is especially worthwhile for multiple axis. Consideration for dissipation of regenerative energy is included. The SFA-07A-RES is equipped with a shunt regulator for dissipation of regenerative energy.

Features

- Efficient power conversion
- High frequency switching
- Resolver feedback
- Simulated encoder signals
- ±10 volts for maximum velocity or torque
- 24 volt I/O for Enable, Reset and Fault output
- Differential analog channel
- LED diagnostic indicators
- Motor and amplifier thermal protection
- AC, I/O and bridge transient suppression
- Totally self contained space efficient design
- Simple screw terminal interface
- AC in rush protection
- Quasi Trapezoid operation

Specifications

Parameter	Specification
Operating Environment: Temperature Humidity	0 to 45°C (32 to 113°F) Maximum, Ambient 0 to 95% noncondensing
Power Input: SFA-03A-RES SFA-07A-RES	5 amps 10 amps 80 to 260 Vac or Vdc 45 to 63 Hz
Output: SFA-03A-RES SFA-07A-RES	3 amps continuous, 6 amps peak 7 amps continuous, 14 amps peak Peak = 5 second minimum PWM frequency = 18 kHz Commutation = 4-Pole, 6-Pole, 8-Pole and Brush (header pins) Current or Velocity operating mode (header pin) Motor inductance = 2 mH minimum
Diagnostic Indicators: Green LED Red LED	POWER/MARK MOTOR/FEEDBACK/AMPLIFIER/CONTINUOUS
Fault Protection: CONTINUOUS AMPLIFIER FEEDBACK THERMAL	This fault occurs if the amplifier has to produce current beyond its continuous rating. The power device is protected for shorts, excess thermal operation and under voltage. Non-logical commutation errors are detected. The motor and MPA-07A-RES shunt load are protected by thermal switches.
Fuses: AC INPUT SHUNT (SFA-07A-RES)	AC input fuses on L1 and L2. A 5-amp fuse is in series with the shunt load.
Adjustments: (25 turn potentiometer) BAL CUR RESP SIG LEAD	The balance adjustment is used to zero any unwanted input offset. The current limit adjustment limits the current. The response adjustment is used to maximize performance in the velocity mode. The signal adjustment is provided to scale the command input voltage ratio. Lead gain compensation is provided to stabilize excess inertia in the velocity mode.

Parameter	Specification
Inputs and Outputs: GND FAULT	Open collector NPN transistor output occurs if a fault condition exists (30 Vdc VCEO .125 A max).
RESET	This input is used to clear the fault status indicators.
ENABLE	Must be connected to GND for amplifier to operate.
GND SIG-/SIG+	Differential input amplifier for command signal. ±10 Vdc = maximum velocity/current.
Resolver Feedback: SHLD GND TS GND SIN GND COS GND REF	Shield connection Thermal switch return Thermal switch Sine return Sine signal Cosine return Cosine signal Reference return Reference signal
Simulated Encoder Signals: Hardware Signals Type Accuracy Resolver Cable Length 25 foot 50 foot 100 foot	9-pin Cannon D-type female connector TTL differential line driver with 510 ohm pull-up resistors. 90° 2-channel signals. 1024 or 4096 lines per channel (header pins). Mark is 5-bits of 12-bit mode. A, A\, B, B\, M, M\ Max. Error ±20 minutes ±30 minutes ±40 minutes
Miscellaneous: Weight Speed/Torque Regulation Max Speed	4 lbs maximum ±5% 6000 rpm in 14-bit mode 12000 rpm in 12-bit mode

Mechanical Footprint

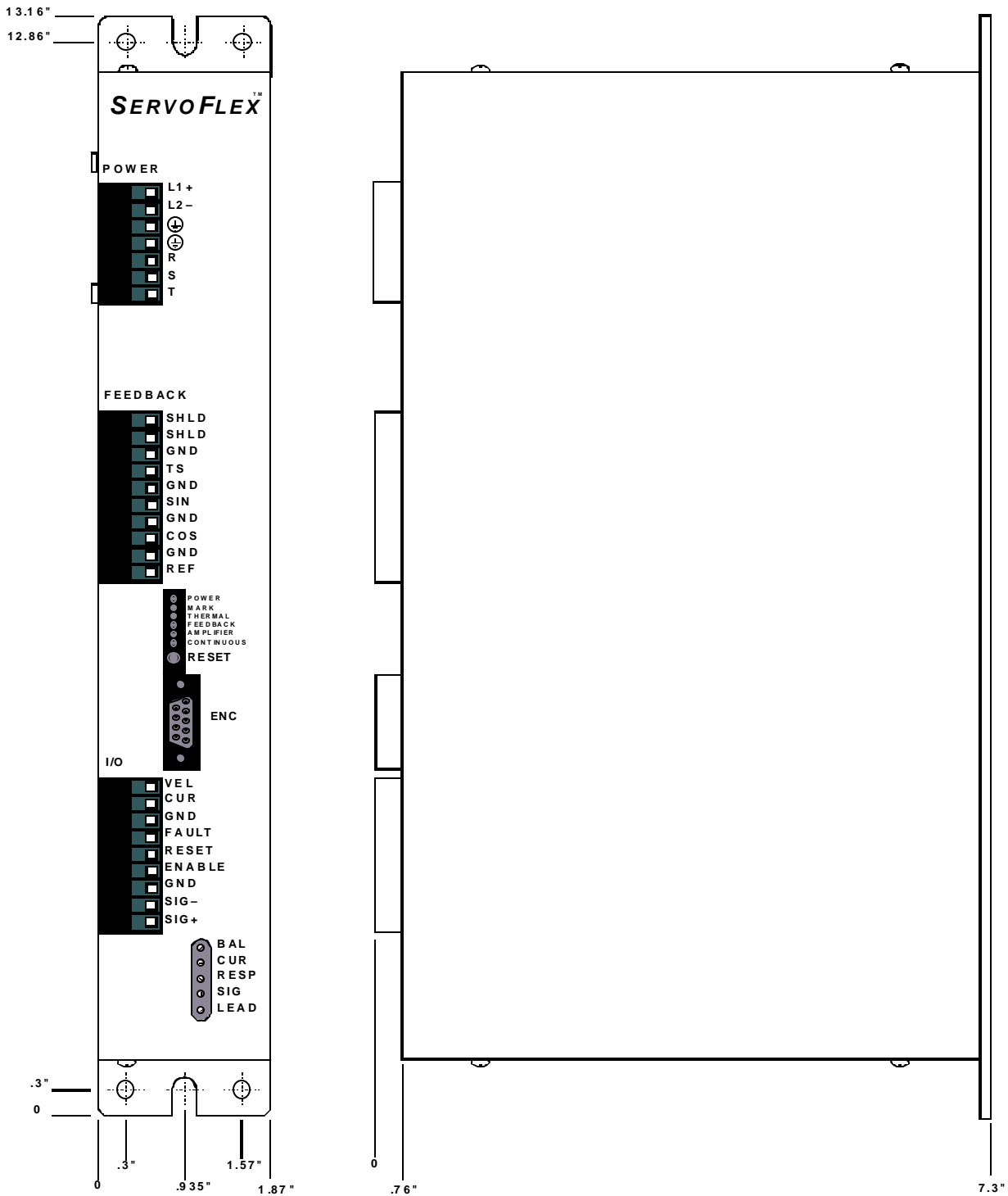

Feedback Wiring

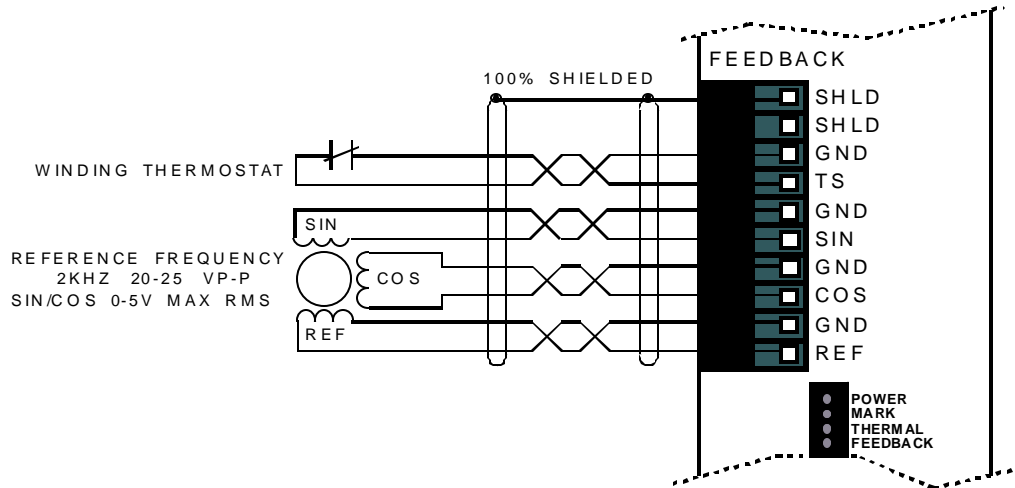

NOTE

100% shielded cable is foil and braid. The pairs do not have to be twisted. The resolver wiring should not be run adjacent to any non-shielded high voltage wires, such as the motor wires (RST). If the wiring cannot be separated then the RST motor leads should also be 100% shielded. It is highly recommended that factory cable sets or wiring be provided.

Thermostat

If the motor is equipped with a winding thermostat that is normally closed, it can be connected between terminals 7 and 8 of the feedback wiring connector. If an excess temperature thermal condition exists as indicated by an open thermostat, drive current is disabled.

If the motor does not have a thermostat, install a jumper from TS to GND.

Diagnostic Indicators

There are six faults that will reduce amplifier current to zero.

LED	INDICATION
CONTINUOUS (RED)	This fault occurs if the amplifier has to produce current beyond its continuous rating.
AMPLIFIER (RED)	The power device is protected for shorts, excess thermal operation, and under voltage. For the SFA-07A and its shunt load, Hi-bus voltages are sensed and this fault occurs if voltages of 440 Vdc occur. The actual shunt turn on voltage is 400 Vdc.
FEEDBACK (RED)	Non-logical feedback errors are detected.
THERMAL (RED)	A thermal switch in the motor windings opens at excess temperature. The SFA-07A has a shunt load resistor mounted in the base plate. This is protected with an 85°C thermal switch. If either a motor thermal fault or shunt load thermal fault occurs, this fault comes ON.
MARK (RED)	This is an output that comes ON at the resolver zero position and can be used in conjunction with alignment procedures. The zero position is about .5 degrees.
POWER (GREEN)	If logic +5 Vdc is ON then this LED is ON.

Configuration

The configuration can be changed before installation by removing the mating connectors and cover (four screws). The default configuration of the amplifier's header pins are as follows:

JP1 = N, JP2 = UP, JP4 = IN, JP5 = IN, JP6 = OUT
JP7 = LFT, JP8 = LFT, JP9 = IN, JP10 = OUT

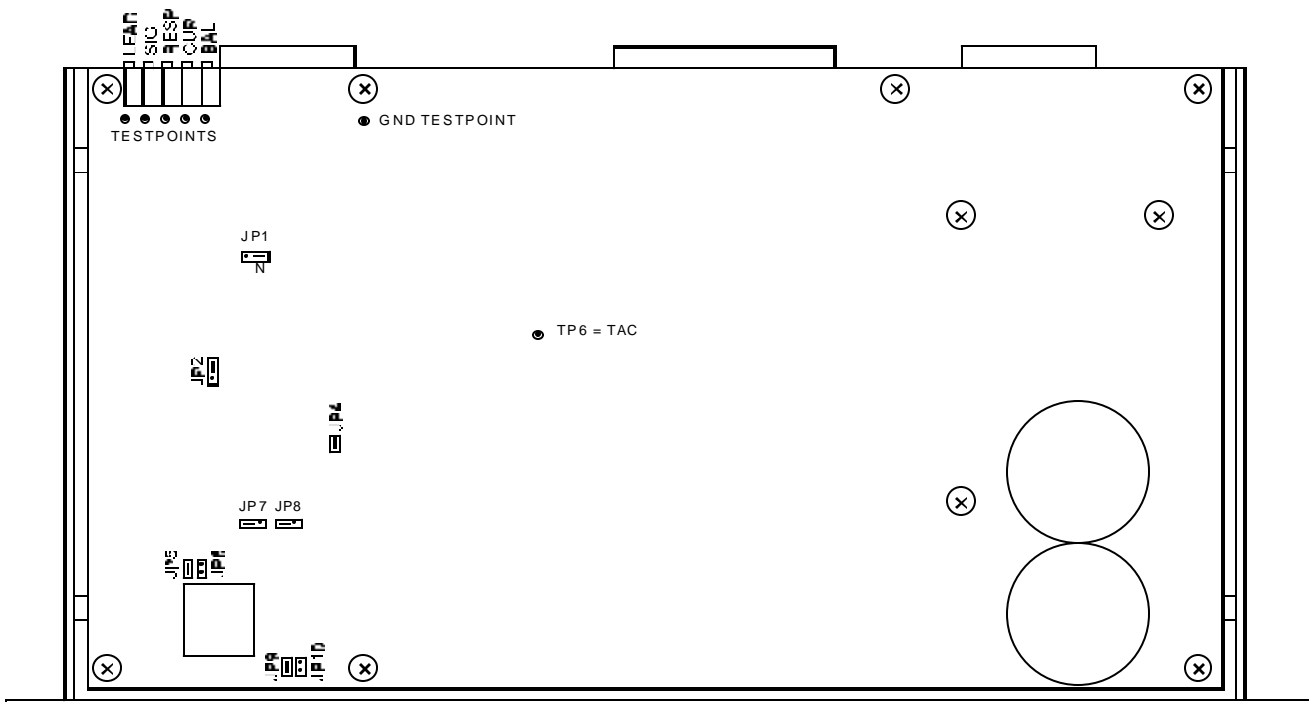

Jumpers

TAC Polarity

JP1 = N

The dc voltage proportional to velocity is at the I/O terminal marked VEL. With this jumper in the N position (right) the VEL voltage is negative for CW shaft rotation. By moving the jumper to the not N position (left) the VEL voltage would be positive for CW shaft rotation.

VELOCITY/TORQUE (current) Mode

JP2 = UP

With this jumper in the UP position, the amplifier is in the velocity mode. By placing this jumper in the DN position, the amplifier is in the TORQUE (current) mode of operation. The SIG and CUR adjustments control the amount of command voltages in either mode.

Torque Linearization

JP4 = IN

This jumper allows the amplifier to linearize the current in the motor based on shaft position. This feature allows the amplifier to compensate for the minor change in flux density that occurs as a result of the sine wave characteristic of the motor. With the feature enabled (standard jumper in) torque is linearized.

R-D Converter Resolution

JP5 = IN, JP6 = OUT

The amplifier is configured for operation in the 14-bit mode. The maximum tracking rate of the amplifier is limited to 6000 rpm. In the 12-bit mode of operation the tracking rate can be 12000 rpm. Although the operation and speed of the amplifier can be changed by relocating the jumpers the R-D converter has been normalized for 14-bit operation. JP5 = OUT and JP6 = IN is the jumper configuration for 12-bit operation. When 12-bit operation is used, it is not possible to have simulated encoder resolution of 4096 lines.

Simulated Encoder Resolution

JP7 = LEFT, JP8 = LEFT

The default resolution of encoder signals is 1024 lines per channel, two channel quadrature with mark. The resolution can be altered to 4096 lines by placing the JP7 and JP8 pins in the RIGHT position.

Motor Commutation

JP9 = IN, JP10 = OUT

The amplifier is set to commutate 6-pole motors. These jumpers allow for a multiple number of choices.

JP9	JP10	Motor Type
IN	IN	8-pole
IN	OUT	6-pole (default)
OUT	IN	4-pole
OUT	OUT	Brush

For brush motor operation, no resolver alignment is required. The R lead connects to armature (+) and the T lead connects to armature (-). Positive commands would cause CW rotation of the motor shaft.

Simulated Encoder Signals

For external counting or position control, a 9-pin D type female connector that has TTL differential outputs is provided. This simulates quadrature encoder channel A and channel B signals. A differential mark signal is also available.

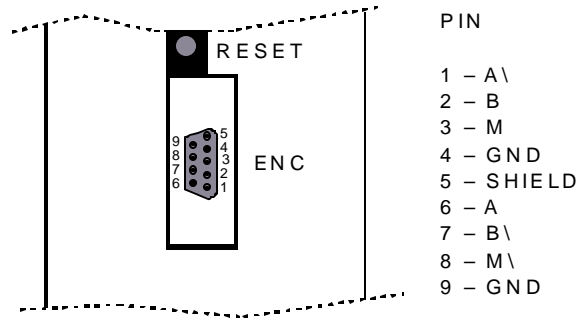

The phase relationship of channels A, B and M are as follows for CW rotation:

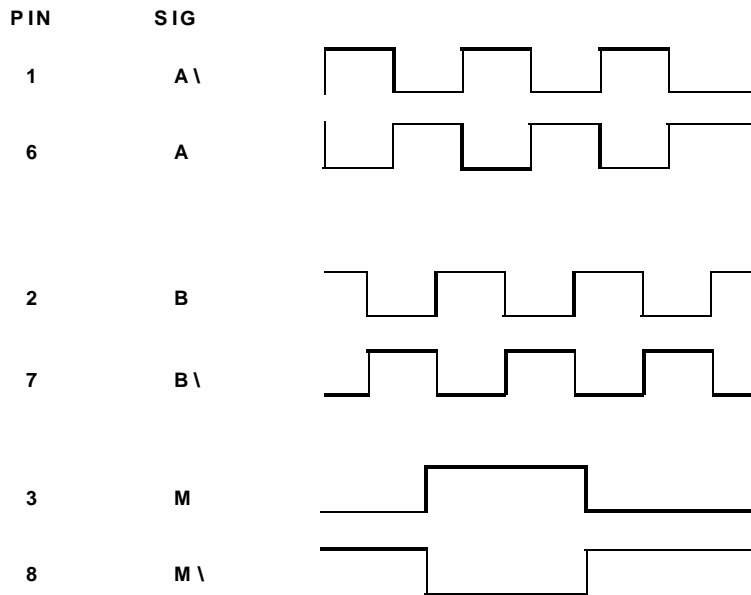

The marker pulse is about .5 degrees in width. The above illustration is for 1024 line condition (default).

The above signals are TTL differential outputs from a DS26LS31 differential driver. The logic 0 is typically between 0 and .5 volts and logic 1's are typically between 3.3 and 4 volts.

I/O Wiring and Descriptions

The amplifier has two inputs and one output. These inputs and outputs are designed to interface to a 5-24 volt logic system. The operation of the inputs and outputs is as follows.

The enable input must be connected to GND to enable the amplifier. If a fault occurs, the appropriate LED will turn ON, and the amplifier will become disabled. Faults can be cleared by pressing the reset button or by momentarily connecting the reset input to GND.

A fault is an open collector NPN transistor whose emitter is connected to GND. This transistor turns ON when a fault occurs and can be used as an interface control signal. The transistor can sink .125 amps, and the open circuit collector voltage can be 30 Vdc.

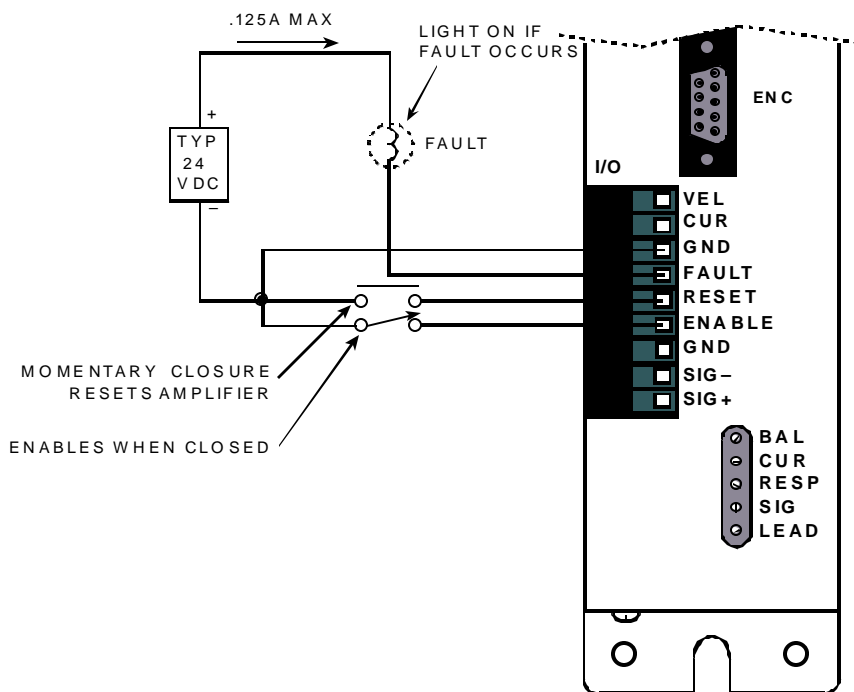

Analog Input, Outputs and Adjustments

Input

There is one analog input channel for command. This is a differential input amplifier. The amplifier is set at the factory to operate in the velocity mode.

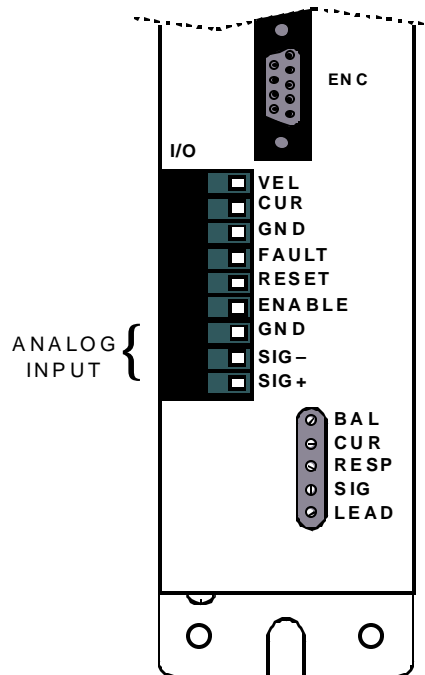

Normal operation of the command signal is to apply a + voltage to SIG+ with respect to GND and get clockwise rotation of the shaft. ± 10 volts is then used to control velocity, and the SIG pot is used for velocity adjustments. If the + COMMAND voltage is applied to the SIG- input, an opposite shaft rotation occurs.

Jumper pin JP2 is normally in the UP position (velocity mode). When this jumper is in the DOWN position, the command voltage controls motor current. The SIG and CUR pots can now be used to adjust the amount. Normal operation in this mode assumes that 10 volts is peak current and 5 volts is the continuous current rating of the amplifier.

The current limit of the amplifier can be adjusted with the CUR pot from 0 (full CCW) to 100% (peak full CW). It is a good idea during start-up to adjust the CUR pot to its full CCW position and increase it slowly CW to assure normal operation.

During start-up the BAL adjustment can be used to reduce/stop any low speed CW/CCW drift in the velocity mode caused by imbalance between the external command voltage and the amplifier.

Once connected to loads, the crispness of motion (step response) and stability can be optimized with the RESP pot. Full CW is maximum response.

Lead is a damping effect and should be turned full CCW to start tuning. A simple procedure is to increase response then increase lead. These adjustments change with load inertia. Large inertia usually requires less response and more lead. Low inertia usually requires more response and less lead.

Once desirable operation is achieved, the pot settings can be recorded. There are test points under each pot and a GND test point near the encoder connector. The pots are set when shipped as follows:

Pot	Setting
LEAD	0
SIG	5K
RESP	7K
CUR	5K

Diagnostic Signals

Ground is any GND connection or SHLD connection.

TAC Gradient

VEL at the I/O connector is the dc voltage proportional to velocity. In the 12 bit mode the TAC gradient is .375 volts per 1000 rpm. In the 14 bit mode the TAC gradient is 1.5 volts per 1000 rpm. CW rotation from the shaft end of the motor produces negative TAC voltage.

Current Gradient

CUR at the I/O connector is the dc voltage proportional to current. 10 volts equals peak. A plus voltage equals CW torque.

Analog Inputs (Specific Interface Requirements)

The analog input allows controllers that have differential output drivers a three wire connection that excludes potential ground loops. When differential modes of operation are used, the command input is based on 5 volts equaling maximum input, and the analog ground from the external controller must be connected to the amplifiers GND connection. A +5 volt connection to the SIG+ terminal and a -5 volt connection to the SIG- terminal is equal to a +10 command voltage. This is what a differential input is and an analog GND connection is required. The rotational direction of the motor will be CW viewed from the shaft end of the motor. To change directional rotation, the SIG+ and SIG- connections must be reversed.

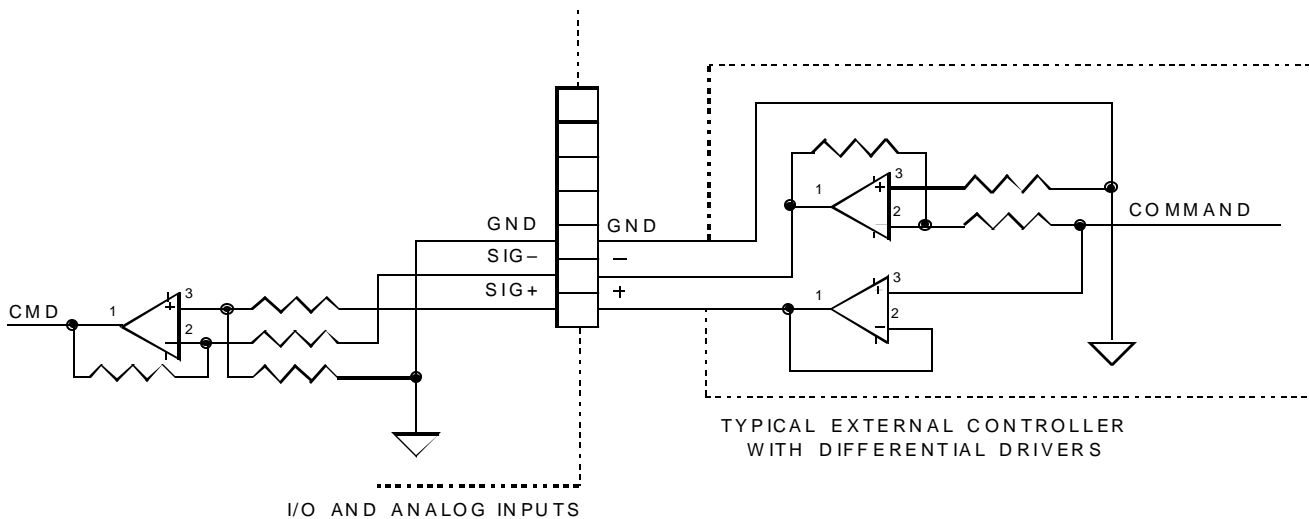

The most typical input to the command and auxiliary inputs is a simple two wire interface consisting of a command voltage with respect to a GND. The GND potential must be connected to the GND connection associated with the analog channel, and the command voltage can be connected to either the SIG+ or SIG- input to determine the rotational characteristic required. A positive command voltage with respect to GND connected to the SIG+ terminal will cause CW rotation as viewed from the shaft end of the motor. The unused input, SIG+ or SIG-, should be connected to GND.

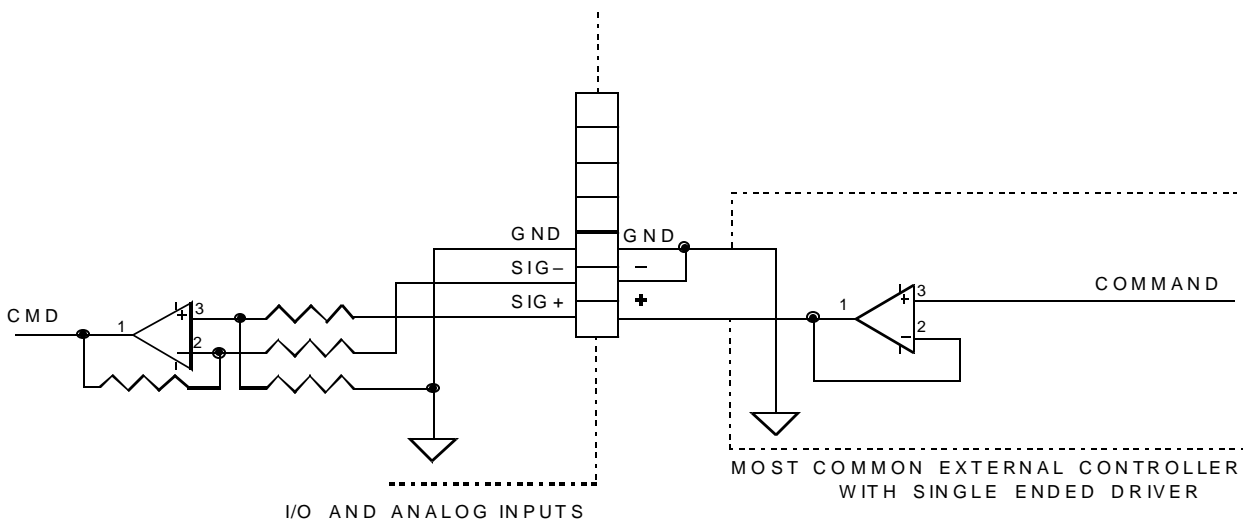

AC Input and Internal Protection

A branch circuit disconnect must be provided in front of the amplifier.

Model	Single Phase
SFA-03A-RES	5 amps
SFA-07A-RES	10 amps

AC power wiring must be consistent with any local codes, national electric codes, and be able to withstand the voltage current ratings applied.

A GND terminal is supplied and should be connected to earth ground.

Internal Protection

The SFA-03/07A-RES has AC Input fuses on the circuit board as a means of protection from catastrophic failures. These fuses are substantially larger than needed. The SFA-07A-RES has a 5 amp PC board in series with the shunt load. In the event that any fuse becomes defective, the amplifier must be repaired by a factory technician.

Grounding – Single Phase

Typical 220 VAC Single Phase

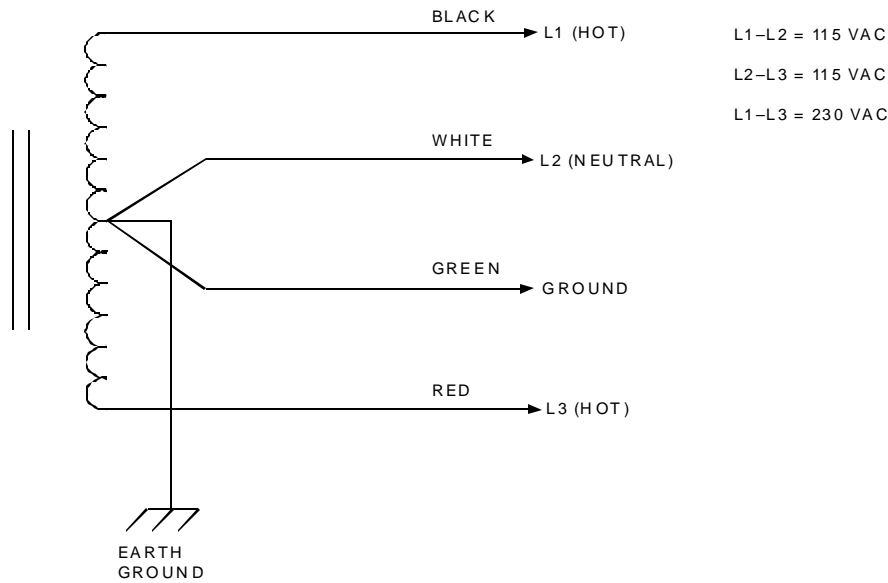

In the United States, the neutral connection is L2 and is a white wire. The green wire is ground. L1 and L3 can be almost any other color but white or green.

Step Down Transformer

Single Phase

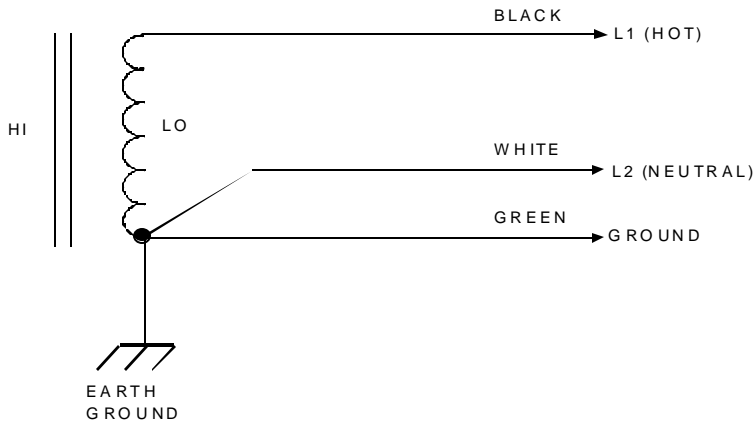

In the United States, the neutral connection is a white wire and the green wire is ground.

For single phase amplifiers, or three phase amplifiers that use a neutral (L2) connection, this connection does not require a switch, fuse, or other means to disconnect. The disconnects and fuses go in the hot leads.

Single Phase Amplifiers on Three Phase Power

In certain multiple single phase amplifier applications, a three phase power source exists. An assumption that the single phase amplifiers can be applied on a three phase transformer and balanced operation can be achieved, by connecting as follows, is incorrect.

NOT ACCEPTABLE:

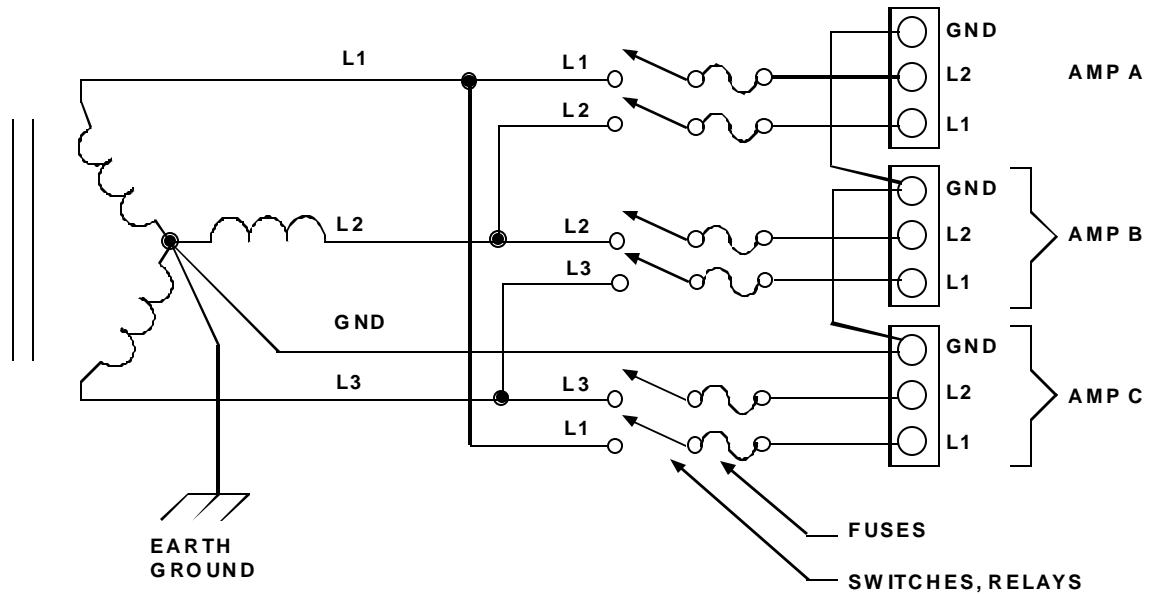

This is not acceptable and can become a major cause of amplifier failures when the transformer is undersized. The most common failure occurs as a result of inrush current at the time power is applied. There are no relays or switches that close at the same time. Therefore, the results are that imbalanced lines cause excess voltages that are destructive. Similar destruction can occur as a result of excessive loads on one axis imbalancing the lines.

Single phase amplifiers should be connected, in parallel, to a single phase line. The line must have sufficient power to drive as many amplifiers connected based on the sum of their continuous ratings.

Three Phase Line to Multiple Single Phase Amplifiers

Since the amplifier designs are based on switch mode techniques, they will operate on dc or pulsating dc voltages.

To balance the three phase transformer, a three phase rectifier can be placed between the amplifiers and the transformer.

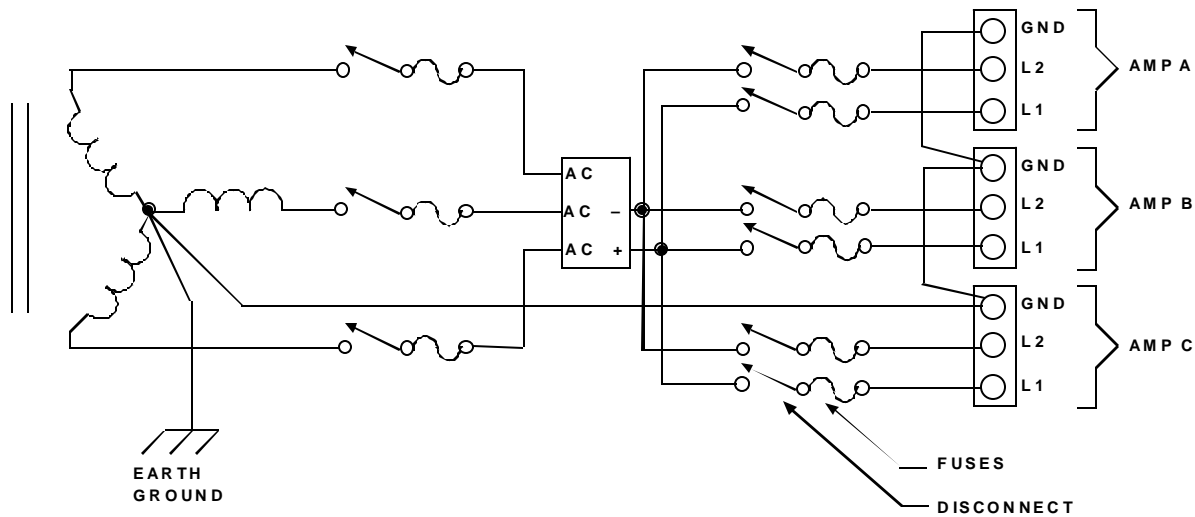

There are multiple acceptable ideas based on this concept. A three phase rectifier for each amplifier is also acceptable.

For multiple amplifiers, there are two choices of three phase bridges available:

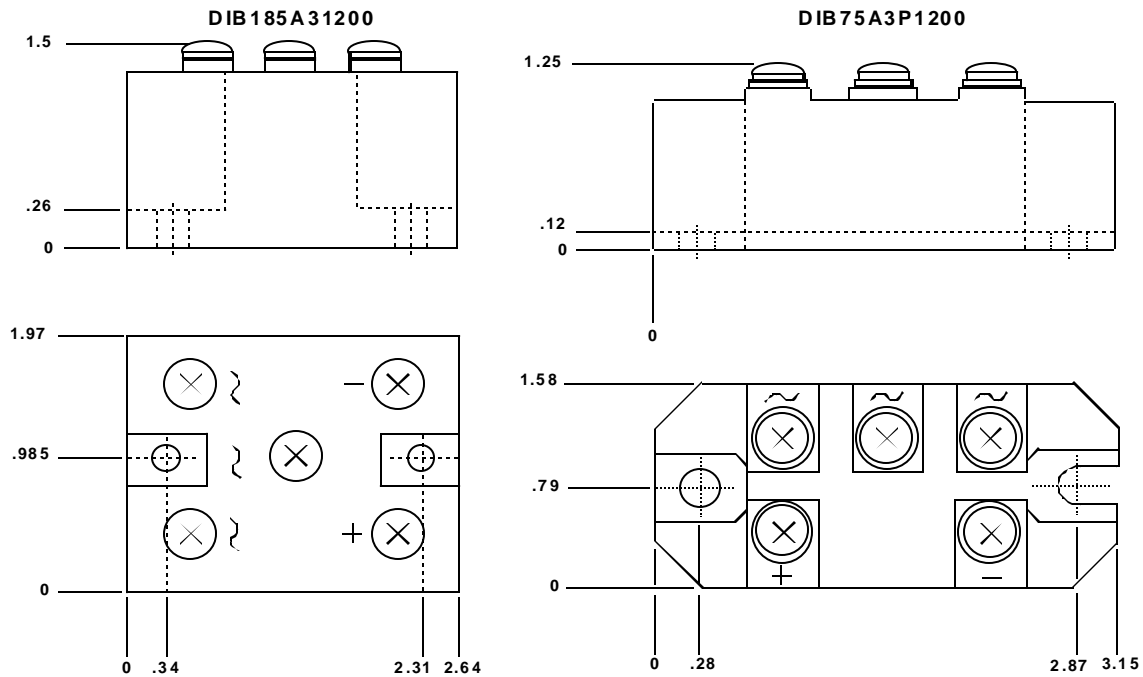

The DIB185A31200 is rated for 90 amps continuous, and the DIB75A3P1200 is rated for 40 amps continuous. The sum of the continuous ratings of the amplifiers divided into the bridge rating without a remainder determines the selection.

Grounding – Three Phase

The ac supply source for the amplifier is supposed to be bonded to earth ground.

Typical WYE Secondary

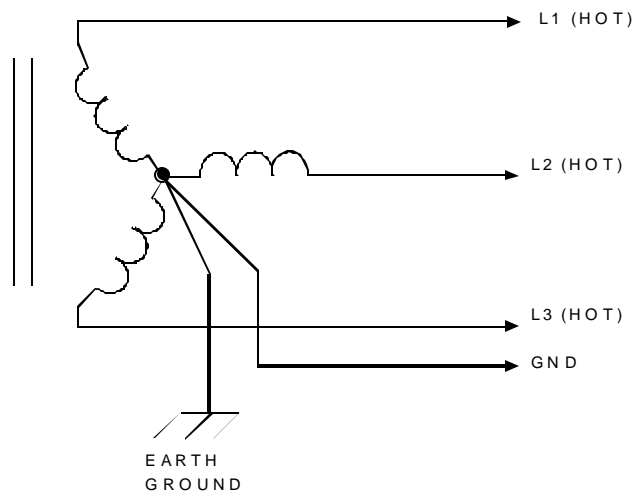

Typical Delta Secondary

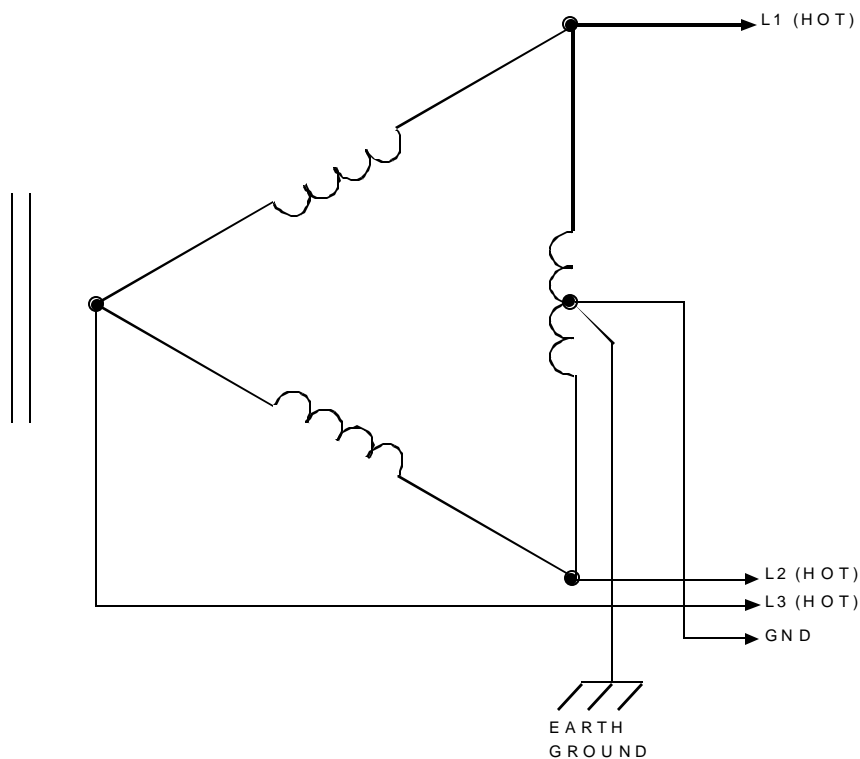

These are the two most typical transformer configurations, and failure to ground these properly could void warranty.

The amplifier does not care where the earth ground is. This example is a delta secondary.

Delta Secondary

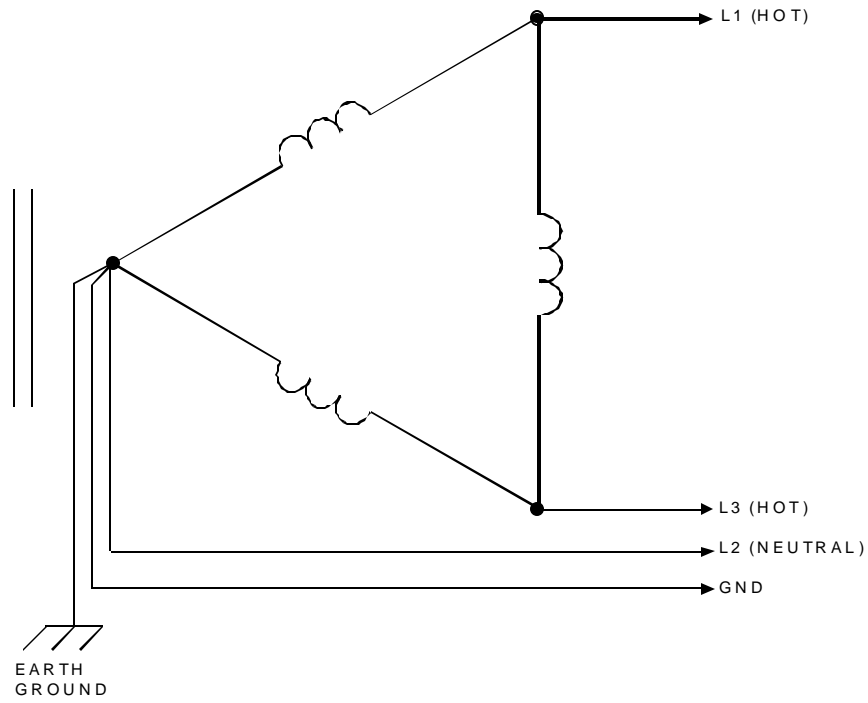

In this example L2 became ground.

Power/Grounding Requirements

The following information covers the grounding requirements of 3-phase servo amplifiers manufactured by MTS Automation. It has been found when an amplifier has been connected to a transformer with an ungrounded secondary, premature amplifier failure will occur.

The 3-phase MPA amplifiers require the AC power (L1, L2, L3, and Ground) be derived from a transformer which has its secondary intentionally bonded to earth ground. This means that some point on the secondary must be connected to an earth ground with no exceptions (see examples A1, A2, A3). Do not assume just because there are three power leads with a ground available at an installation, that this is a valid configuration. Some facilities are supplied with 13,200 volts AC which is reduced to 460 volts AC via a transformer. However, the secondary of this transformer usually is not grounded as in an ungrounded delta secondary (Example U3). Each installation or facility is unique and the power distribution must be inspected or measured to make sure the transformer secondary is, in fact, tied to earth ground. A machine or system built and tested at one facility, may fail at another site due to incorrect transformer configurations.

There are two common transformer secondary configurations. They are the Wye and the Delta secondary. Most problems are found with an ungrounded Delta secondary connection. The examples show acceptable (A1, A2, and A3) and unacceptable (U1, U2, U3) configurations.

If it is not possible to visually inspect the transformer configuration, you can electrically measure the line voltages to verify a correctly grounded transformer secondary.

A properly grounded secondary (wye or delta) will have certain voltage characteristics when measured with an AC volt meter:

- A properly grounded wye secondary will read the same voltages when measuring all three legs, phase to ground (A1).
- A properly grounded wye or delta secondary will read the same voltage when measuring all three legs phase to phase (A1, A2, A3).

A properly grounded delta with high leg (A2) and delta with grounded leg (A3) show different characteristics when measuring phase to ground.

- In example A2 (Delta with high leg), the two low legs (L1 and L2) must be the same voltage when measured phase to ground.
- In example A2 (Delta with high leg), the high leg (L3), when measured phase to ground, will read twice the value of L1 or L2 to ground.
- In example A3 (Delta with grounded leg), L1 and L2 must be the same voltage when measured phase to ground.

If the measured voltages at the installation do not correspond with the above, or the transformer secondary is, in fact, ungrounded, one of the following steps must be done:

- A) Ground the secondary of the transformer if it is electrically and mechanically possible.
- B) Add an isolation transformer and ground the secondary per acceptable connection.

If unsure, ask a licensed electrician to perform the above steps.

Example 1 shows a typical factory configuration. It shows a ungrounded delta secondary and there is existing equipment already running, on line. This equipment could be simple 3-phase induction motors where an ungrounded secondary is not an issue. However, before a 3-phase MPA amplifier, or a machine utilizing 3-phase amplifiers, can be connected, an isolation transformer, with a grounded secondary must be installed.

Everyone, (OEM's, End users, etc.) must be made aware of this possible situation when a machine is installed at a customer's site. The power distribution needs to be known and a transformer, with a grounded secondary, may need to be added to the system before power is applied.

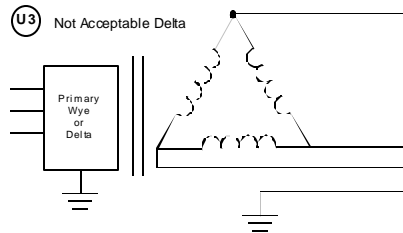
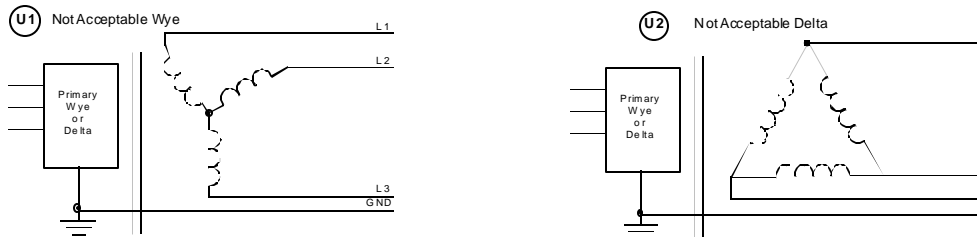
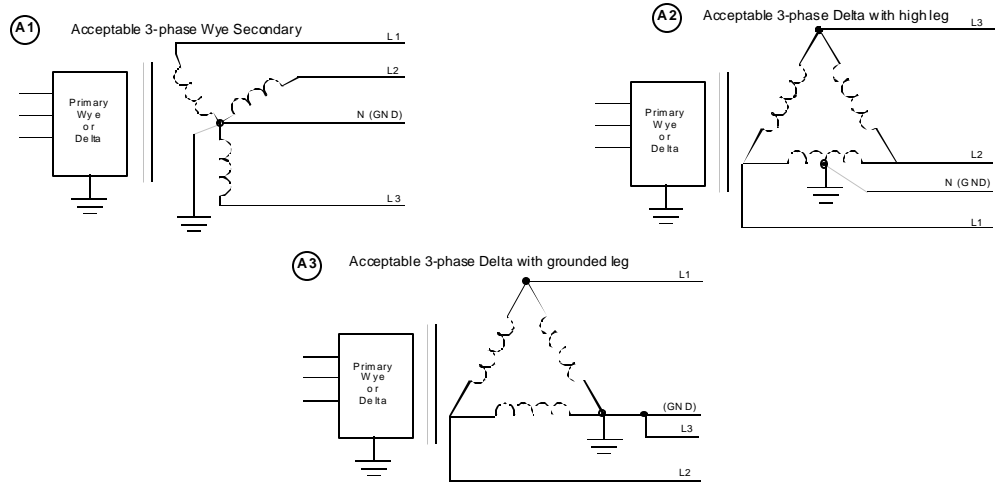

If you find one of the unacceptable connections above, you must:

- A. Ground the secondary if possible
- B. Add an isolation transformer per acceptable connection (See example 1 below)

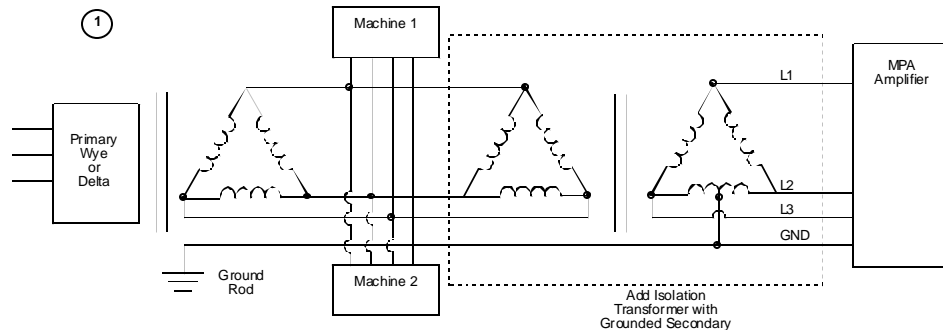

Stator Wiring

The locked rotor stator current is equal to the amplifiers continuous rating, and for either low speed or locked rotor conditions the stator must withstand this continuous rating. Derating the stator /wiring for three phase operation is not allowed.

Model	Locked Rotor
SFA-03A-RES	3 amps
SFA-07A-RES	7 amps

For operation at 230 Vac, it is recommended that the stator wiring insulation withstand 600 volts.

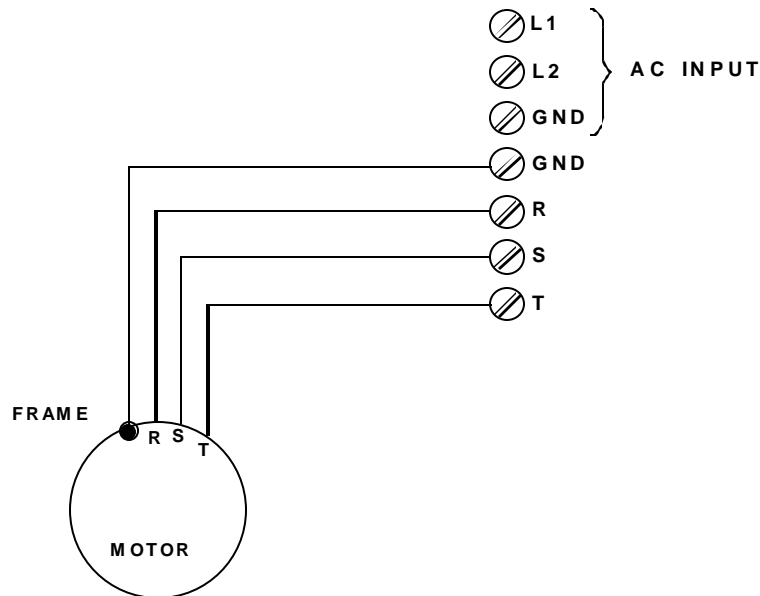

A GND connection is supplied as a means to ground the motor frame to earth ground.

If shielded cable is not used, it is recommended that the RST and GND wires be twisted.

NOTE

If the resolver feedback wiring is to be run adjacent to the RST motor wiring, then the motor wiring should be 100% shielded (foil and braid).

"-S" Separated Supply Option

The availability of a -S option is to allow the removal of power from the motor circuits connected to RST. During the time power is removed, the feedback device power is operational by having connected a separate AC line source to a 120 Vac connection on the drive.

When the normal power is removed, the drive will produce a fault because the normal DC bus power is removed, and the drive is not operational when this occurs. The AMPLIFIER fault comes on. This fault has to be cleared after the bus AC power is reapplied.

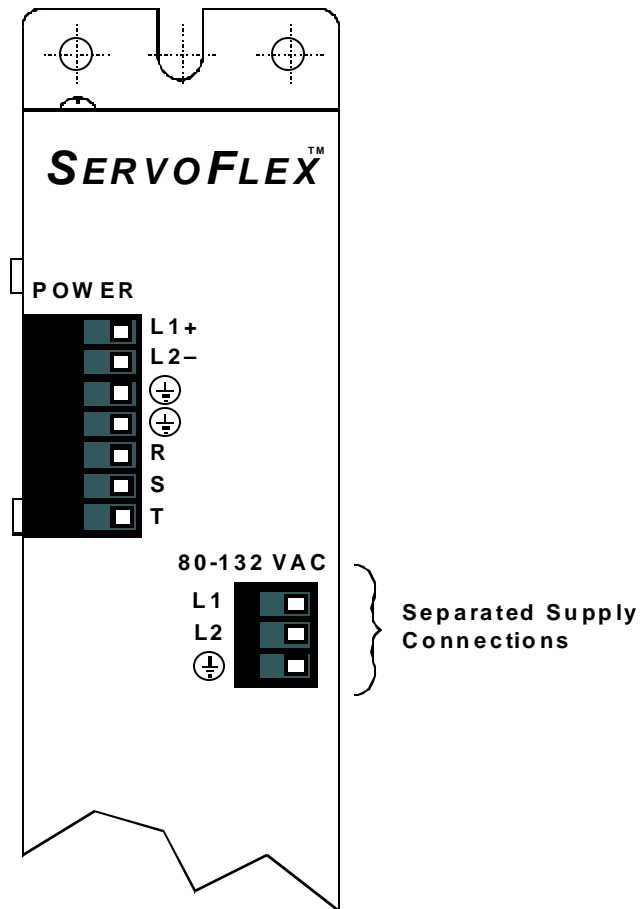

Thermal Characteristics

The amplifiers are specified to operate at a 45° C ambient. This is not a maximum safe operating specification. There are no parts in the amplifier that cannot operate at a 60° C temperature. The absolute maximum temperatures that the amplifier can operate at are determined by thermal switches on the bridge switch power devices (IGBTs) and on the shunt loads. These thermal switches open and disable the amplifier at 85° C.

At temperatures above 45° C, the amplifier's ability to produce its continuous rating is impaired by the heat rise from the ambient temperature. The amplifier will thermally shut down once the 85° C condition is sensed at either the bridge or the shunt load.

A guideline for enclosures would be to assume that the amplifier's thermal rise caused by the bridge is 16 times the continuous current rating of the amplifier plus 30 watts. The 30 watts is required for the logic supplies.

If the application is causing bus pumping, and the SFA-07A-RES with shunts is being used, the thermal rise from the shunts is restricted to 85° C. The thermal rise of the shunt would be equal to the bridge, and as a guideline, the shunt thermal rise could equal the bridge.

Example for a SFA-07A-RES in a highly regenerative application:

SFA-07A-RES = 7 amps continuous

7 x 16 = (bridge rise)		112 watts
plus 30 watts	+	30 watts
plus 112 watts regenerative	+	112 watts
		<hr/>
Total		254 watts

The shunt load in the amplifier is a 24 ohm resistor and it is protected with a 5 amp fuse. The shunt load is placed in parallel with the bus capacitors at 400 Vdc.

Start-Up

Once normal wiring is verified, power can be applied to the amplifier.

Assure the header pin settings are what are required. Default settings are for 6-pole motors.

The CUR and RESP adjustments are set to about one half.

It is recommended that CUR be turned to its full CCW position. Once power is applied, CUR can be slowly increased in a CW direction to achieve shaft torque. Crispness can be increased by a CW adjustment of RESP and damping occurs with a CW adjustment of LEAD.

For start-up verification of wiring with external position controls, the following simple test can be used to verify the phase relationship.

With the current limit turned full CCW, or with the RST wiring disconnected, a CW rotation of the motor shaft will produce a negative command voltage at SIG+ to GND on the I/O connector. For a CCW rotation, a positive command must occur. The rotation is started from a null, or a close to zero shaft position. If the relationship is wrong, there are two choices:

1. interchange the A, A\ and B, B\ signals at the simulated encoder.
2. use the command - input for signal and pin #11 is still ground.

Either method works, but the first method still assures that positive command voltages cause CW rotation of the motor shaft as viewed from the shaft end of the motor.

Typical Wiring

AC INPUT 80-260 VAC 47-63 HZ

NOTE: THE AC INPUT AND STATOR WIRING SIZE VARY BASED ON INSULATION TYPES. CHECK LOCAL CODES AND WIRE MANUFACTURER FOR SPECIFICATIONS.

