

# TABLE OF CONTENTS

---

---

## 1 Before Installation

Unpacking and Inspection .....	1-1
Warranty and Service.....	1-2
Service under Warranty .....	1-2
Non-Warranty Service.....	1-2
General Provisions .....	1-2
Symbols Used in This Manual.....	1-3
Introducing the 8031 Pulse and Direction Interface Card .....	1-4
Parts of the 8031 Pulse and Direction Interface Card .....	1-5

## 2 Status LEDs

Status LED Display .....	2-1
Status LED Location .....	2-1

## 3 Cabling

Connections .....	3-1
Connector Location, Pinouts, and Signal Names .....	3-1
J3 Inputs .....	3-2
J3 Input Circuitry .....	3-2
Typical External Connections to J3 (Set Up as Differential).....	3-4
Typical External Connections to J3 (Set Up as Current Sinking).....	3-4
Typical External Connections to J3 (Set Up as Current Sourcing) .....	3-4
J3 Output .....	3-5
J3 Output Circuitry .....	3-5
Typical Connections to J3 Using Internal +5 Vdc Supply .....	3-6
Typical Connections to J3 Using Internal +12 Vdc Supply.....	3-6
Typical Connections to J3 Using External Supply.....	3-7

## 4 DIP Switch Settings

DIP Switch Locations .....	4-1
Switch 1 .....	4-2
Switch 2.....	4-3
Switch 3.....	4-4

## 5 Tuning

Definitions .....	5-1
Tuning for Velocity Mode.....	5-2
Tuning for Torque Mode.....	5-2

## 6 Jumper Settings

Jumper Locations .....	6-1
Jumper X1 .....	6-2
Jumper X2 .....	6-2

## **7 Installing the EPROM**

Definition.....	7-1
Location .....	7-2
Procedure .....	7-2
EPROM Options .....	7-3

## **8 Troubleshooting**

Introduction .....	8-1
LED Symptoms .....	8-2
Non-LED Symptoms .....	8-3

## **9 8031 Pulse and Direction Interface Card Specifications**

## **10 Running with MPA-03SL or MPA-06SL Amplifiers**

Jumper Locations .....	10-1
TB1 Input/Output Pins .....	10-3
TB1 Input Circuitry .....	10-4
TB1 Output Circuitry .....	10-5
Typical External Connections to TB1.....	10-6

## **11 Running with MPA-230 or MPA-460 ANF3/8031 Amplifiers**

Switch and Jumper Locations .....	11-2
Input/Output Pins .....	11-3
Input Circuitry .....	11-4
Output Circuitry .....	11-5
Typical External Connections to I/O .....	11-6

# 1 BEFORE INSTALLATION

---

## **Application**

This manual is designed to help you install and operate the 8031 Pulse and Direction Interface Card. It also contains information on running the 8031 Pulse and Direction Interface Card with an MPA-03SL, MPA-06SL, MPA-230 ANF3/8031 or MPA-460 ANF3/8031 amplifier.

---

## **Unpacking and Inspection**

Carefully unpack the 8031 Pulse and Direction Interface Card and inspect it for visible damage. Check items against the packing list. Report any missing or damaged items to your supplier.

---

# Warranty and Service

---

The 8031 Pulse and Direction Interface Card is warranted to be free from defects in workmanship and materials for a period of 18 months from the original shipment by MTS Automation, or 12 months in service, whichever comes first.

During the warranty period, a defective 8031 Pulse and Direction Interface Card unit will be repaired or replaced as outlined below.

Before requesting return authorization, please try to verify that the problem is within the 8031 Pulse and Direction Interface Card, and not with external devices.

To arrange for repair or replacement, please contact:

**MTS Automation Customer Service**  
**(507) 354-1616**  
**(800) 967-1785**  
**Monday–Friday, 8:00–4:30 Central Time**

- You must provide the model and serial number from the labels on the 8031 Pulse and Direction Interface Card and the reason for returning the unit.
- You will be issued a return authorization number which must be marked on the return shipment and on all correspondence.

---

## Service Under Warranty

- Return your defective unit, freight prepaid, and it will be repaired and returned within two weeks of receipt via regular UPS, freight prepaid.
- Upon request, a factory-repaired replacement unit will be sent via regular prepaid UPS, within four working days. Next day shipment for overnight delivery, freight collect, is available at an expediting charge of \$100. The defective unit is to be returned via regular UPS, freight prepaid, upon your receipt of the replacement.

---

## Non-Warranty Service

- Return your defective unit, freight prepaid, and it will be repaired on a time and material basis and returned within three weeks of receipt.
- OR contact your local distributor or MTS Automation Customer Service for a factory-repaired exchange unit, which is available at a flat rate price, assuming the defective unit is in repairable condition and is returned freight prepaid. Next day shipment for overnight delivery, freight collect, is available at an expediting charge of \$100.

---

## General Provisions

Except as specifically modified by this warranty statement, all MTS Automation Conditions of Sale and Warranty shall apply.

---

# Symbols Used in This Manual

---

The following symbols are used in this manual to identify different kinds of information:

**NOTE**

This symbol indicates a note that gives you important additional information.



**CAUTION**

This symbol indicates that caution must be used to avoid losing valuable data or causing minor damage to equipment.



**WARNING**

This symbol indicates that extreme care must be used to avoid causing personal injury or equipment damage.

---

# Introducing the 8031 Pulse and Direction Interface Card

---

The 8031 Pulse and Direction Interface Card is a closed loop position controller that uses either pulse and direction or CW and CCW inputs as its source for motion commands. It plugs into various MTS Automation amplifiers to create a single package, stand-alone digital servo controller/amplifier providing a single axis of digital position control.

- 12 bit D/A for analog command.
  - 800  $\mu$ s position control loop update period.
  - Open collector fault output.
  - Switch selectable loop and feedforward parameters (Scale, Kp, Kd, Kff).
  - Switch selectable mode of operation (velocity, torque).
  - Three color LED status indicator.
  - Isolated inputs.
  - Maximum input pulse rate of 500 kHz.
  - Current sinking or sourcing pulse and direction inputs (CW and CCW inputs).
  - 12 bit analog output,  $-10$  V to  $+10$  V full scale.
-

# Parts of the 8031 Pulse and Direction Interface Card

---

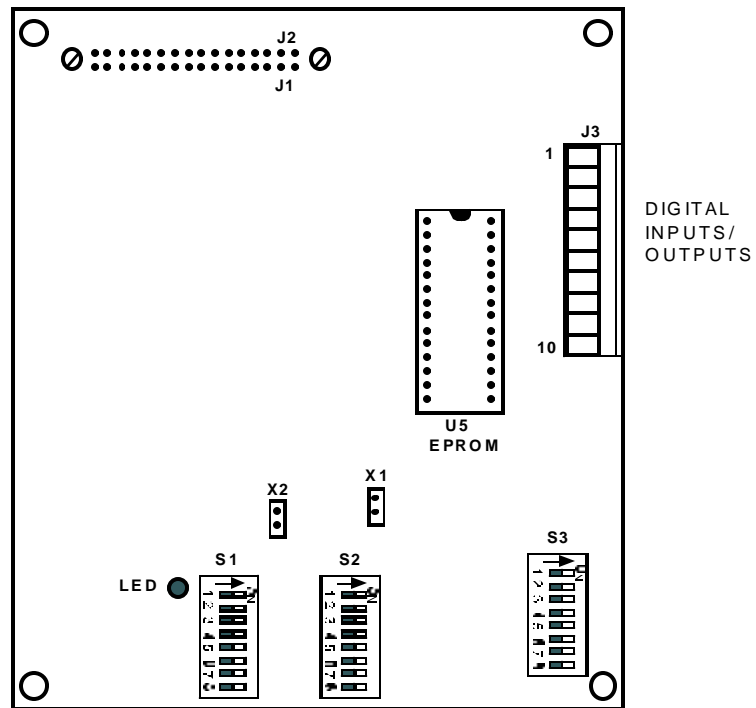

## 2 STATUS LED

---

### Status LED Display

The three color LED located on the 8031 Pulse and Direction Interface Card displays its status as shown in the following table:

LED Display	Condition
OFF	Power to the card is off.
ORANGE	State of the card after power-up/reset until the processor finishes power-up procedures.
BLINKING GREEN	Normal operating condition of the card.
BLINKING RED	An error condition was detected as follows: Blinking twice – Excess error was detected. An excess error occurs when the difference between the commanded and feedback positions is greater than 168 degrees.  When this error occurs, the command into the amplifier card is set to zero and the fault output turns on.

---

### Status LED Location

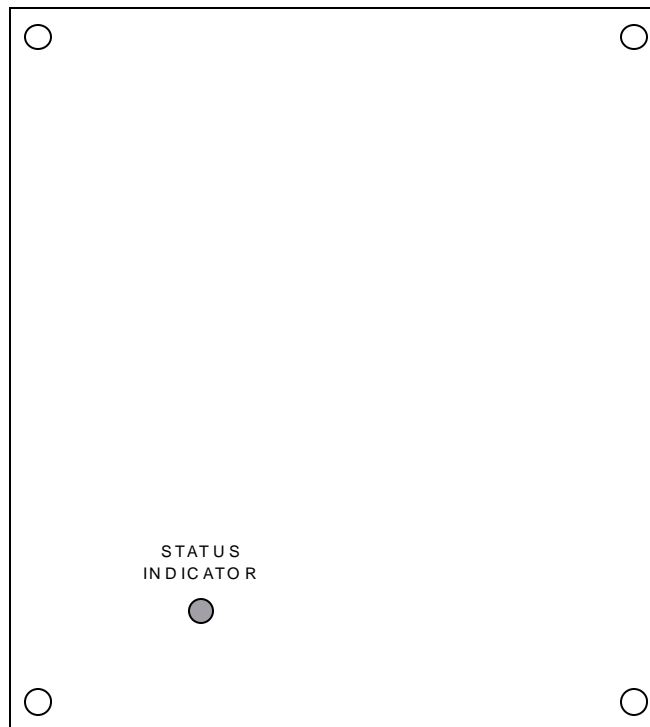

# 3 CABLING

---

## Connections

There is one user connector located on the 8031 Pulse and Direction Interface Card. J3 contains the stepper interface signals, fault output, power, and  $\pm 10$  V analog output.

---

## Connector Location, Pinouts, and Signal Names

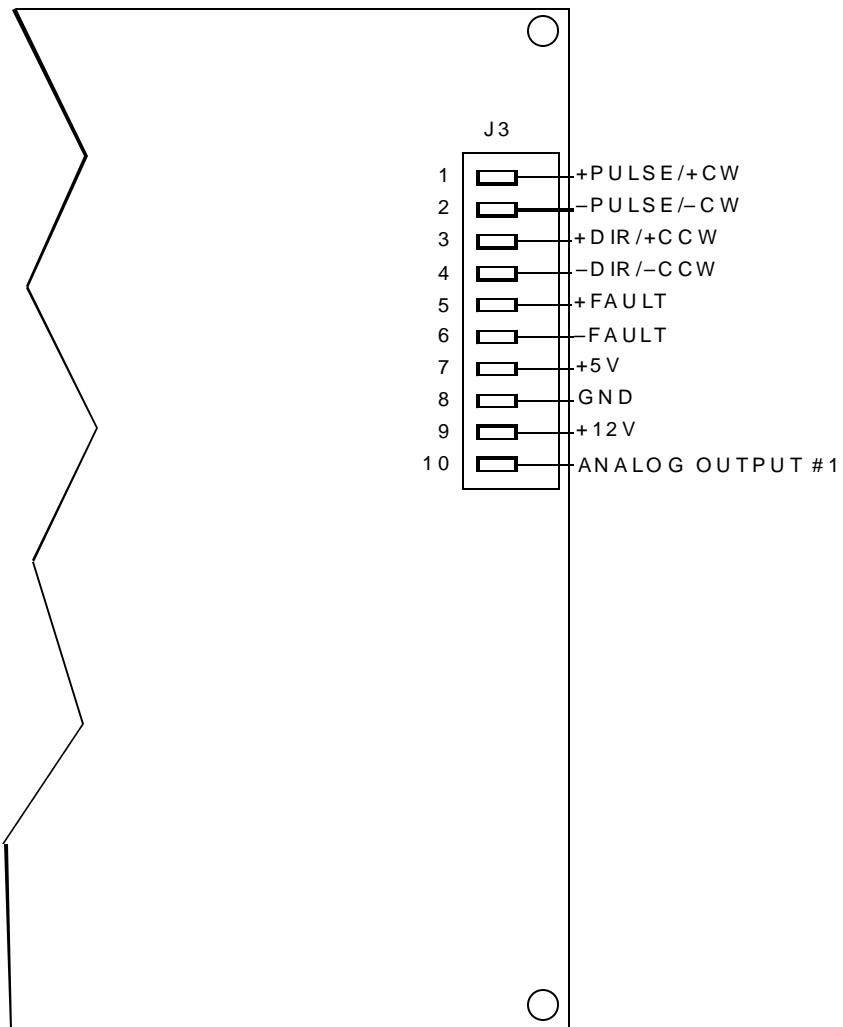

# J3 Inputs

J3 contains two optically isolated inputs that can be programmed to be used as external pulse and direction or CW/CCW input. The following diagram shows the internal structure of these inputs.

## J3 Input Circuitry

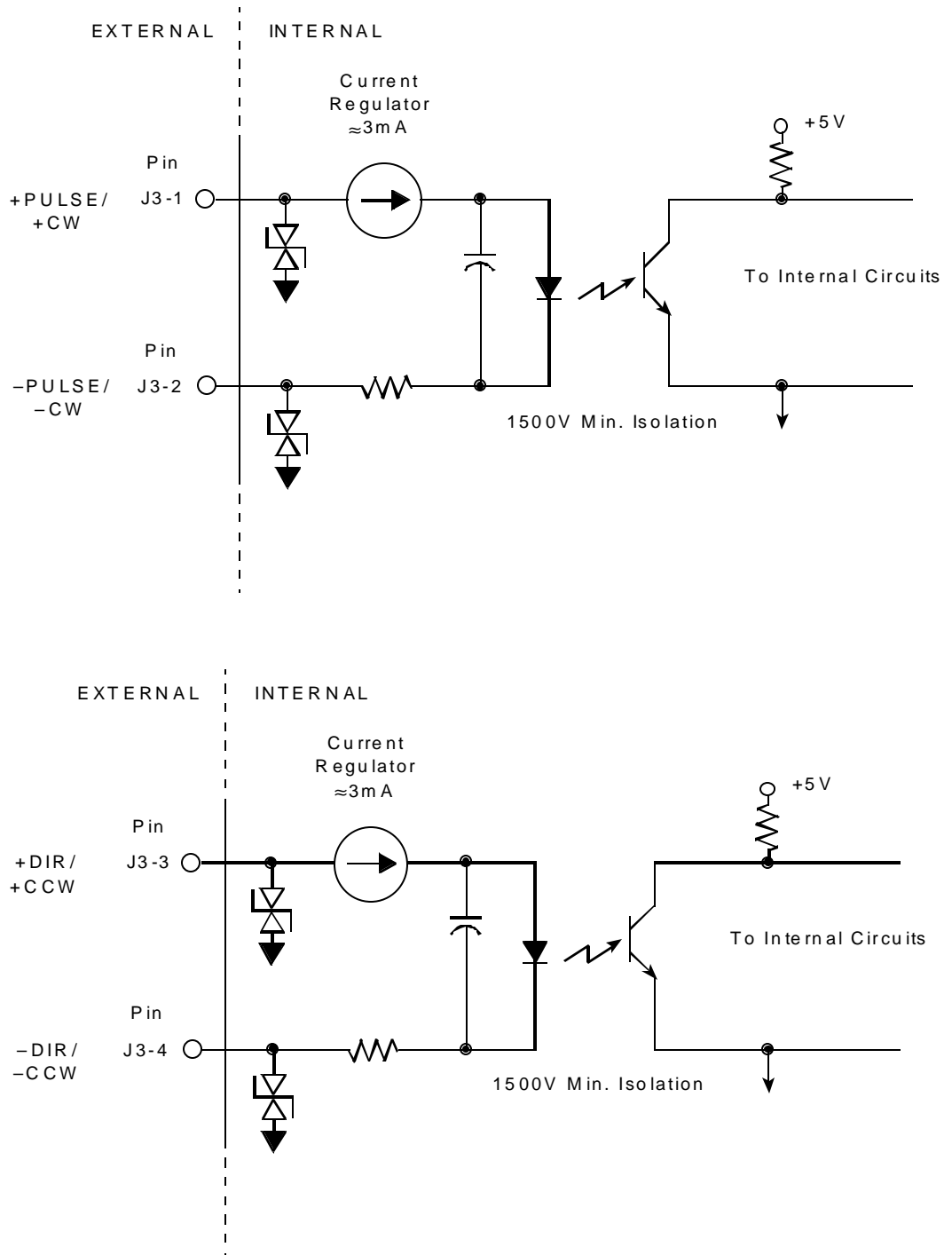

Continued on next page

## J3 Inputs (continued)

---

J3 Input Specifications:	
Input ON Voltage	5 to 30 Vdc
Input ON Current	10 mA maximum
Input OFF Voltage	1 Vdc maximum

The PULSE input to the 8031 Pulse and Direction Interface Card must be at least 1  $\mu$ s wide with a maximum input frequency of 500 kHz. The DIRECTION input must be set at least 250 ns before the leading edge of the PULSE input.

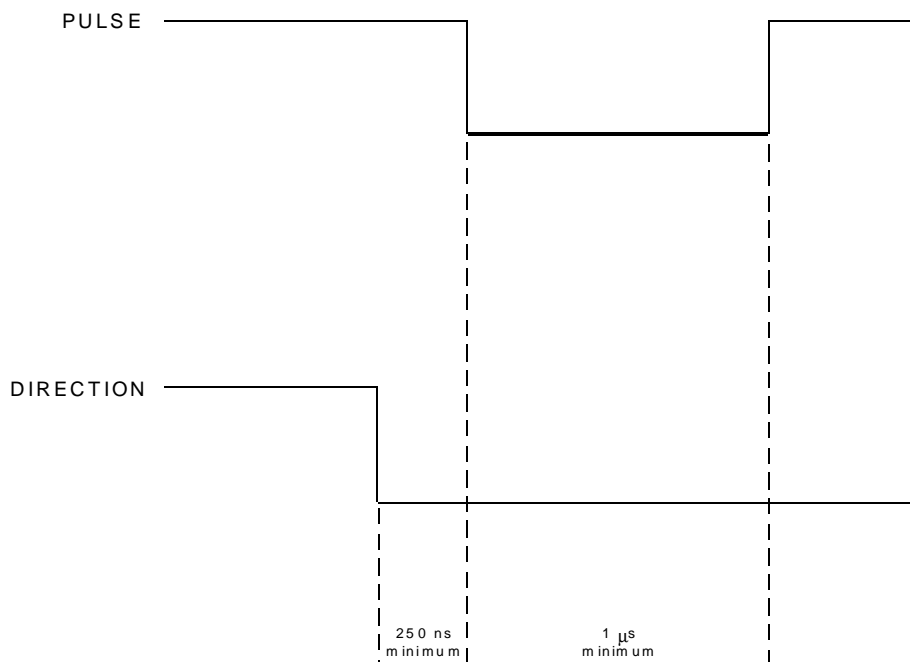

The CW or CCW inputs to the 8031 Pulse and Direction Interface Card must be at least 1  $\mu$ s wide with a maximum input frequency of 500 kHz.

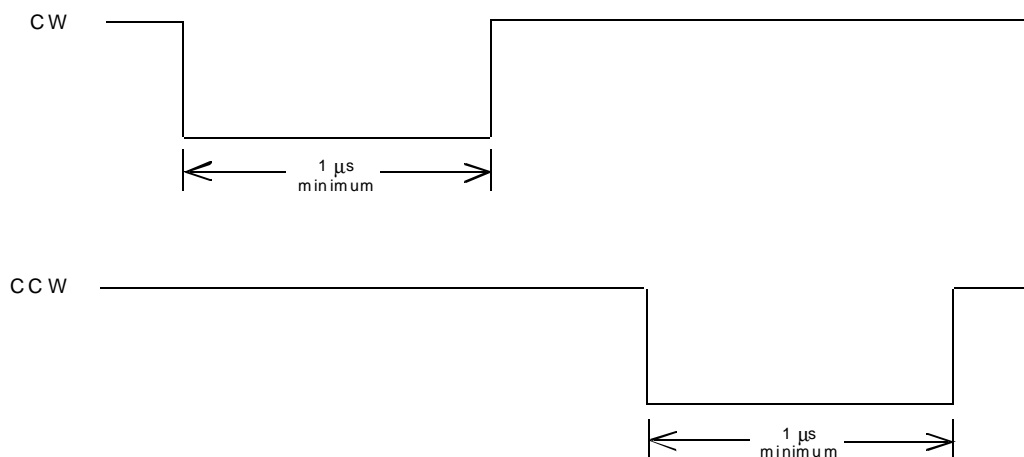

# J3 Inputs (continued)

J3 can use an external 5 – 30 Vdc power source if isolated inputs are required. Note that inputs on J3 can be either differential, current sinking or sourcing.

## Typical External Connections to J3 (Set Up as Differential)

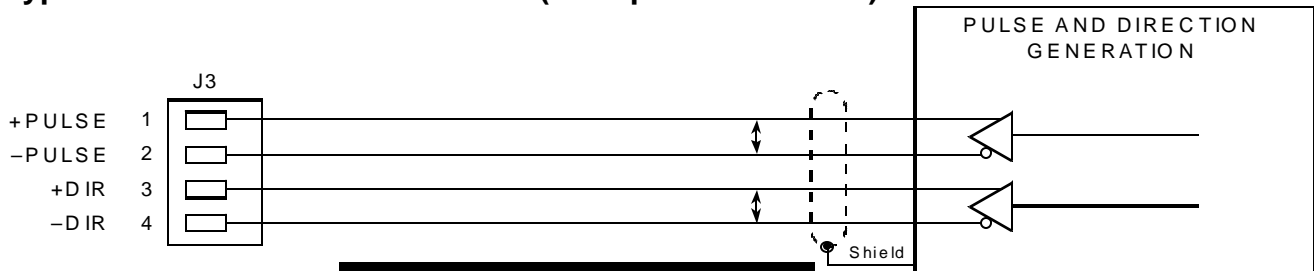

**NOTE**

Twisted pair with overall foil and braid shielded wire recommended.

## Typical External Connections to J3 (Set Up as Current Sinking)

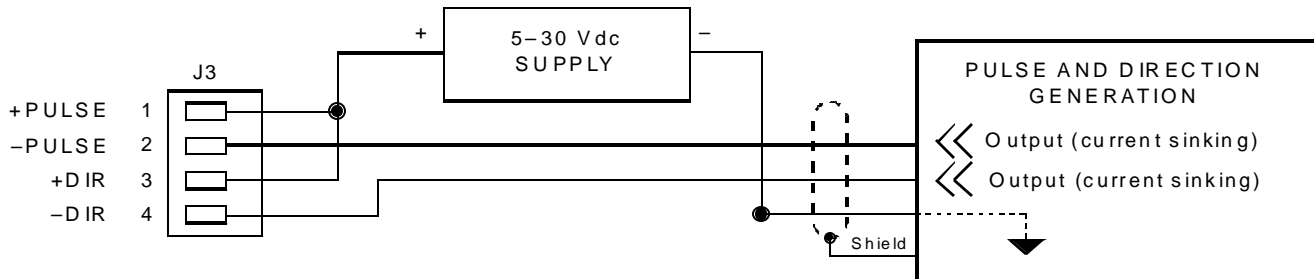

Typical wire size for digital inputs is 16 – 24 gauge.

**CAUTION**

Polarity of input is critical. Lead reversal can damage inputs.

**NOTE**

Open collector outputs may require an external pull-up resistor.

## Typical External Connections to J3 (Set Up as Current Sourcing)

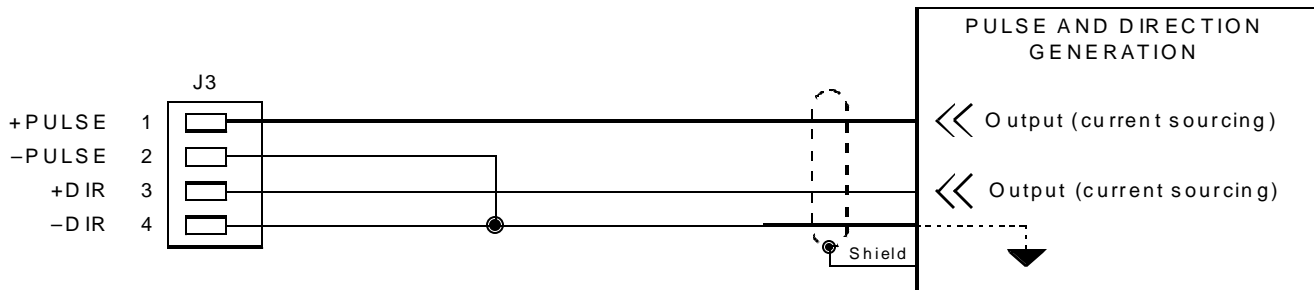

Typical wire size for digital inputs is 16 – 24 gauge.

**CAUTION**

Polarity of input is critical. Lead reversal can damage inputs.

# J3 Output

J3 contains an optically isolated output to indicate a fault condition on the 8031 Pulse and Direction Interface Card. The following diagram shows the internal structure on this output.

## J3 Output Circuitry

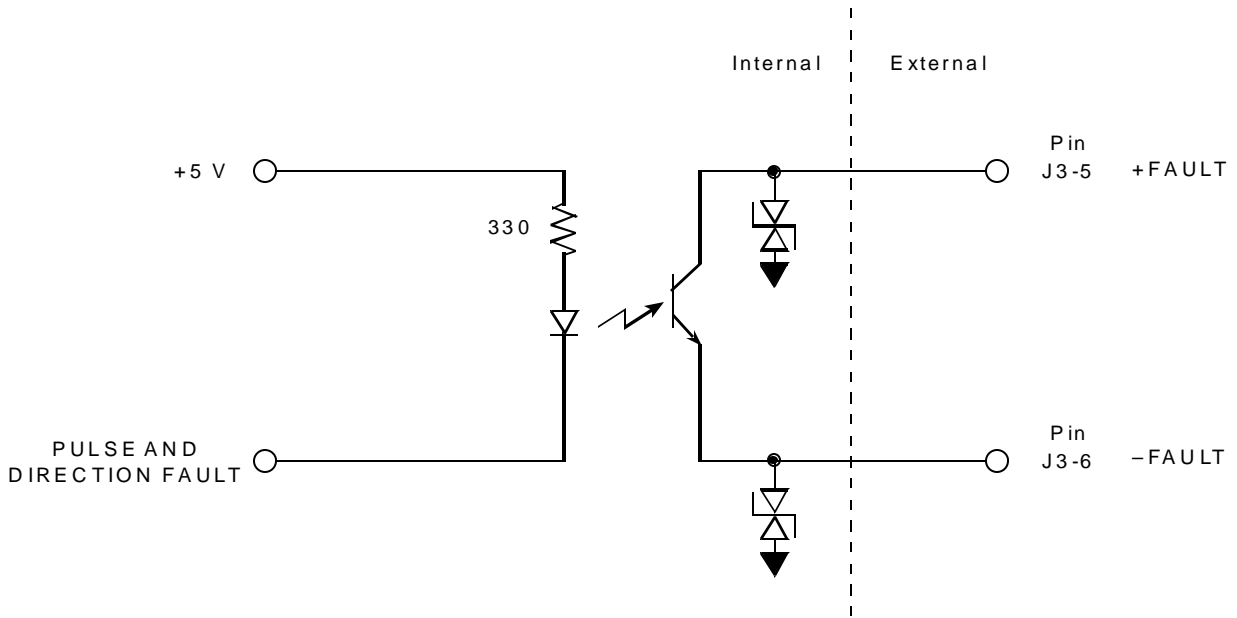

J3 Output Specifications:	
Output Current	15 mA minimum

*Continued on next page*

## J3 Output (continued)

The 8031 Pulse and Direction Interface Card FAULT output can use the internal +5 Vdc or +12 Vdc supplies, or an external supply.

### Typical Connections to J3 Using Internal +5 Vdc Supply

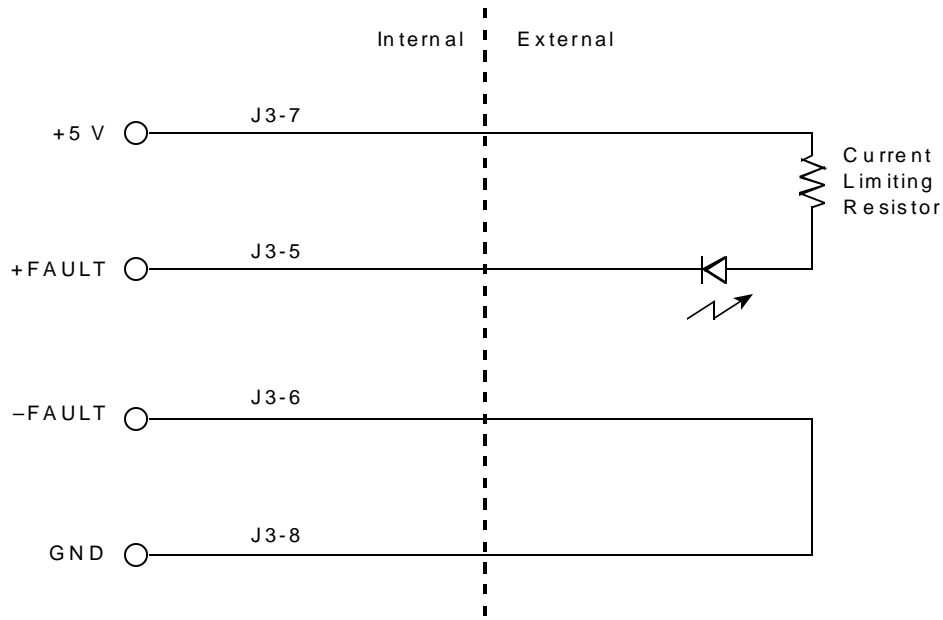

### Typical Connections to J3 Using Internal +12 Vdc Supply

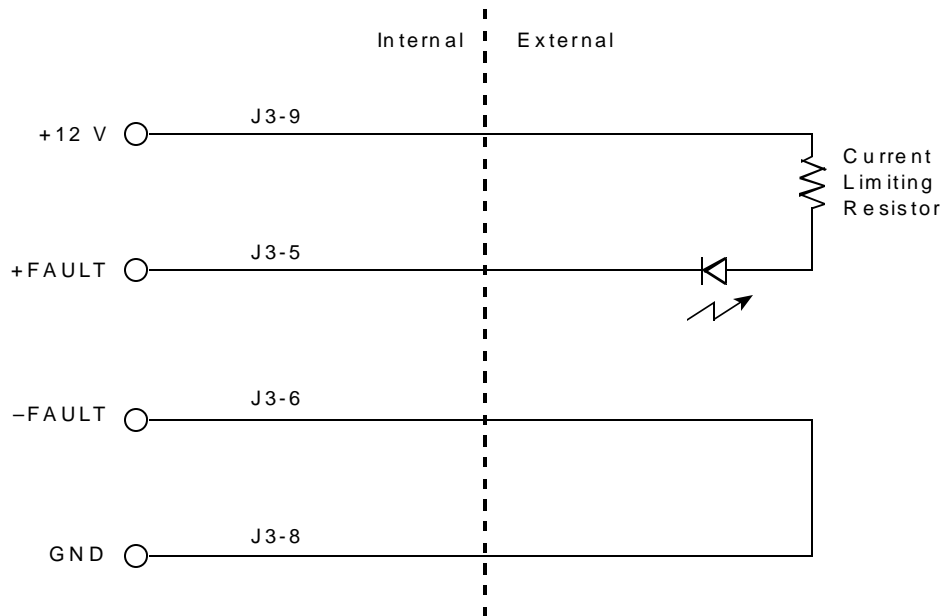

*Continued on next page*

# J3 Output (continued)

---

## Typical Connections to J3 Using External Supply

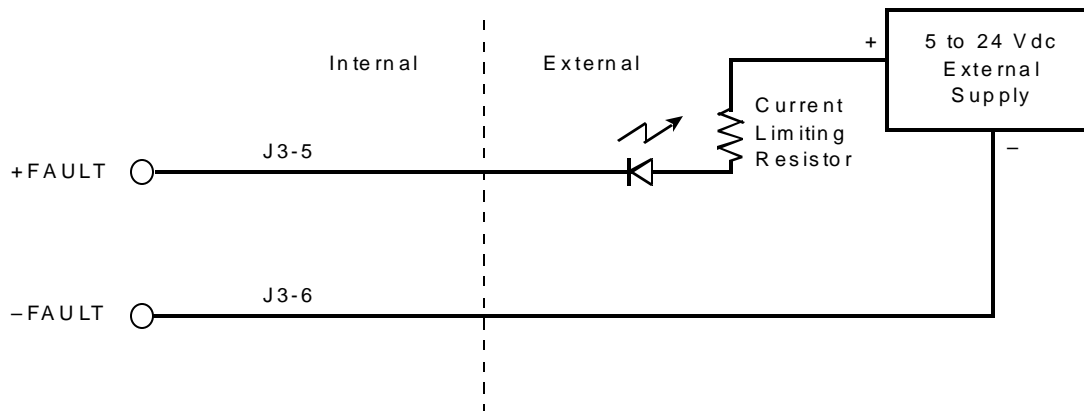

### NOTE

Choose the value of the current limiting resistor so that the current flowing into the +Fault output will be less than or equal to 15 mA when its output voltage is 0 volts.

---

# 4 DIP SWITCH SETTINGS

---

The 8031 Pulse and Direction Interface Card contains three 8-position DIP switches. The switches are used for the following functions:

- Tuning (Kp, Kff, Kd).
- Setting pulses per revolution (scale).
- Setting torque or velocity mode.

### NOTE

Switches are read only once after a reset condition. Changing switch settings after a power-up reset will have no effect until the next reset occurs.

---

## DIP Switch Locations

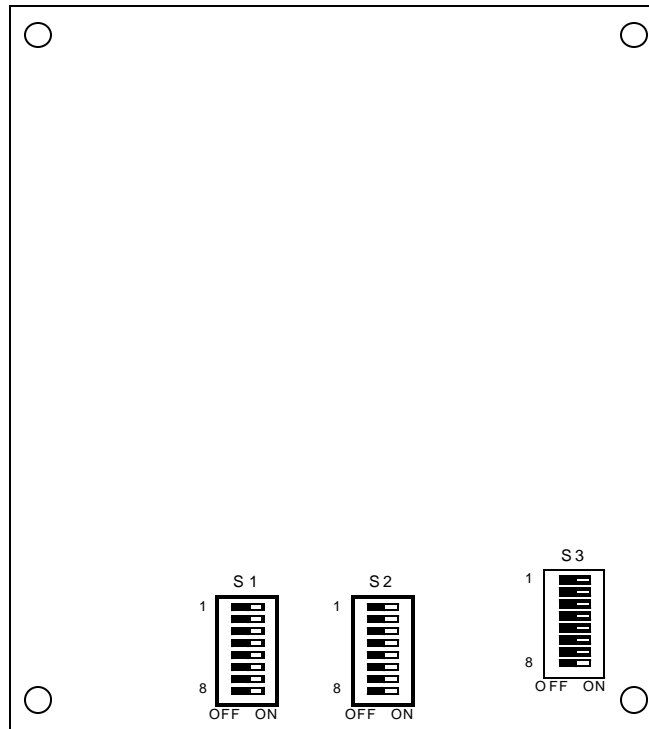

*Continued on next page*

# DIP Switch Settings (continued)

---

## Switch 1

### Positions 1 and 2

Used to select the number of pulses per revolution as shown below.

For EPROM U5:

POSN1	POSN2	Pulses Per Revolution P/N 491395-01	Pulses Per Revolution P/N 491395-02	Pulses Per Revolution P/N 491395-03
OFF	OFF	400*	512*	1000*
OFF	ON	1000	1024	2000
ON	OFF	2000	2048	3000
ON	ON	4000	4096	4000
* Factory Setting				

### Position 3

Used to tell the 8031 Pulse and Direction Interface Card whether it is issuing a velocity command or a torque command to the amplifier.

#### NOTE

Always ensure that the amplifier is set correctly for velocity or torque mode.

POSN3	Mode
OFF	Velocity *
ON	Torque
* Factory setting.	

### Position 4

Switch position 4 has no current function. It should be set in the OFF position.

*Continued on next page*

# DIP Switch Settings (continued)

---

## Positions 5 to 8

Used to select the value of Kff for the position loop. This is represented as a four-bit binary number. Switch position 5 is the most significant digit and position 8 is the least significant digit.

POSN5	POSN6	POSN7	POSN8	Relative Kff Value
OFF	OFF	OFF	OFF	Zero *
OFF	OFF	OFF	ON	Lowest non-zero value
•	•	•	•	•
•	•	•	•	•
•	•	•	•	•
ON	ON	ON	OFF	Next to highest value
ON	ON	ON	ON	Highest value
* Factory setting.				

---

## Switch 2

Switch 2 sets the value of Kp for the position loop. It is represented as an eight-bit binary number. Switch position 1 is the most significant digit and position 8 is the least significant digit.

POSN1	POSN2	POSN3	POSN4	POSN5	POSN6	POSN7	POSN8	Relative Kp Value
OFF	OFF	OFF	OFF	OFF	OFF	OFF	OFF	Zero *
OFF	OFF	OFF	OFF	OFF	OFF	OFF	ON	Lowest non-zero value
•	•	•	•	•	•	•	•	•
•	•	•	•	•	•	•	•	•
•	•	•	•	•	•	•	•	•
ON	ON	ON	ON	ON	ON	ON	OFF	Next to highest value
ON	ON	ON	ON	ON	ON	ON	ON	Highest value
* Factory setting.								

*Continued on next page*

## DIP Switch Settings (continued)

---

### Switch 3

Switch 3 sets the value of Kd for the position loop. It is represented as a seven-bit binary number. Switch position 2 is the most significant digit and position 8 is the least significant digit. Switch position 1 has no current function. It should be set in the OFF position.

POSN2	POSN3	POSN4	POSN5	POSN6	POSN7	POSN8	Relative Kd Value
OFF	OFF	OFF	OFF	OFF	OFF	OFF	Zero *
OFF	OFF	OFF	OFF	OFF	OFF	ON	Lowest non-zero value
•	•	•	•	•	•	•	•
•	•	•	•	•	•	•	•
•	•	•	•	•	•	•	•
ON	ON	ON	ON	ON	ON	OFF	Next to highest value
ON	ON	ON	ON	ON	ON	ON	Highest value

\* Factory setting.

#### NOTE

Kd is typically not used when running in the velocity mode (compensation is done by the velocity loop on the amplifier).

---

# 5 TUNING

---

Tuning the position loop on the 8031 Pulse and Direction Interface Card is required in order for the motor to closely track the commanded position. To tune the position loop, the motor should be executing motion (preferably some type of start-stop motion).

Always tune both the position loop and the optional velocity loop with the load attached to the motor.

 **WARNING**

Precautions must be taken to avoid personal injury and equipment damage during the tuning process. Unexpected motor movement can be caused by changing the tuning parameters. Use only small increments when changing tuning parameters.

Systems tuned to the edge of stability also create the possibility for unexpected motor movement.

---

## Definitions

- Kp:** Proportional gain. It is multiplied by the following error (the difference between the command and feedback positions). Because Kp provides a signal proportional to the error, a higher Kp reduces error, at the expense of overshoot.
- Kd:** Derivative gain. It is multiplied by the feedback velocity. Kd is used to provide damping to the servo loop. When running in velocity mode, Kd is typically not used because the velocity loop provides the damping.
- Kff:** Velocity feedforward. It is multiplied by the commanded velocity to provide the actuator with a “one-step-ahead” signal. Kff has no effect on closed loop dynamics.
- Overshoot:** The condition that occurs when the motor travels past its commanded position (or velocity) when starting or stopping.
- Oscillation:** The condition that occurs when the motor rotates continuously back and forth (generally at a high frequency), even when there is no commanded change in position.

# Tuning (continued)

---

## Tuning for Velocity Mode

When running in the velocity mode, tune the amplifier's velocity loop first. To tune the velocity loop with the 8031 Pulse and Direction Interface Card plugged in, set all of its gains to zero (except for  $K_p$ , which should be set to a small number) and then tune the velocity loop according to the amplifier's manual. Next, set the value for  $K_p$  to the highest value that does not cause motor oscillation or overshoot. It is recommended that  $K_p$  is then backed off slightly to move the system further away from the point of instability.  $K_d$  is usually not used when running in the velocity mode because this compensation is done in the amplifier's velocity loop. Once  $K_p$  is set,  $K_{ff}$  can be used to reduce following error while the motor is turning. If there is unacceptable following error while the motor is turning, adjust  $K_{ff}$  to minimize the error.

### NOTE

At low values of  $K_p$ , following errors will easily occur on the 8031 Pulse and Direction Interface Card. This happens because  $K_p$  must be set high enough to overcome the "damping" effect of the velocity loop.

---

## Tuning for Torque Mode

Setting the values for  $K_p$  and  $K_d$  in the torque mode is often an iterative process. The process is as follows:

1. Increase the value of  $K_p$  until the system is only marginally stable. At this point, the motor overshoots its target and is coming close to instability (oscillating back and forth). Note the value of  $K_p$ .
2. Move the value of  $K_d$  up until the system is stable again. Note the value of  $K_d$ .

Repeat the two preceding steps until  $K_d$  cannot make the system stable (the overshoot cannot be eliminated or increasing  $K_d$  causes the motor to squeal). Then, use the  $K_p$  and  $K_d$  values from the last stable setting. At this point, the 8031 Pulse and Direction Interface Card is tuned for the current load. If the load will not always remain constant (the inertia and/or friction load may change), it is recommended that you use slightly lower  $K_p$  and  $K_d$  settings because this will move the system further into the stable operating region.  $K_{ff}$ , as in the case for tuning while in the velocity mode, is used to reduce following error while the motor is turning. If there is an unacceptable following error while the motor is turning, adjust  $K_{ff}$  to minimize error.

---

# 6 JUMPER SETTINGS

---

## Jumper Locations

There are two 3-position jumpers located on the 8031 Pulse and Direction Interface Card.

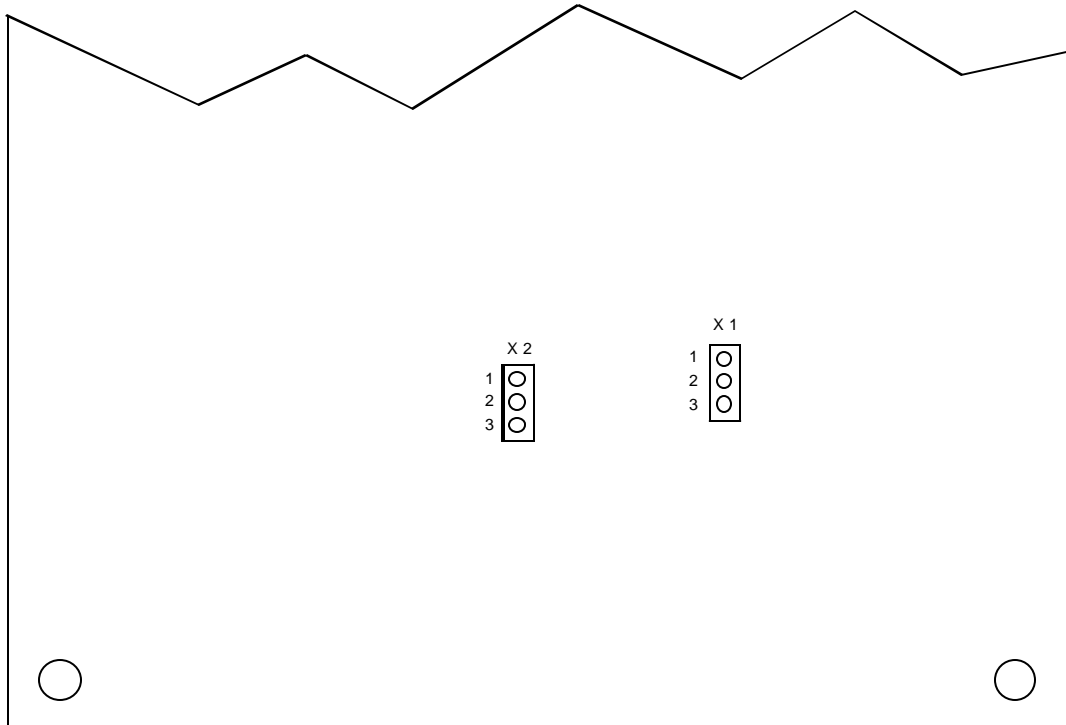

---

*Continued on next page*

## Jumper Settings (continued)

---

### Jumper X1

Jumper X1 position is determined by the input mode, as shown in the following table:

Jumper	Position	Mode
X1	1-2	Pulse/Direction *
X1	2-3	CW/CCW
* Factory setting.		

---

### Jumper X2

Jumper X2 can be used to switch the sense of the motor direction, as shown in the following table:

Jumper	Position	Direction
X2	1-2	Normal *
X2	2-3	Reverse
* Factory setting.		

#### **NOTE**

Jumper X2 options only apply when jumper X1 is set for the pulse and direction mode.

---

# 7 INSTALLING THE EPROM

---

If you receive a new EPROM or need to change your current EPROM, you will need to replace the EPROM located on the 8031 Pulse and Direction Interface Card as described in this section.

---

## Definition

An EPROM is an erasable, programmable read-only memory chip. The EPROM on the 8031 Pulse and Direction Interface Card contains both the code to run the 8031 Pulse and Direction Interface Card and the data for the number of pulses per revolution.

---



### WARNING

Be sure to turn off all power (both ac power and any external supplies) to the 8031 Pulse and Direction Interface Card/amplifier combination before touching any components.



### CAUTION

Do not remove anti-static packaging materials from a component until you are ready to install it.

Anti-static wrist or ankle bands should be attached before touching the circuit card to avoid static discharge, which can damage circuit components.

Except where necessary, avoid touching components or conductive paths on the circuit card.

---

*Continued on next page*

# Installing the EPROM (continued)

---

## Location

Use this diagram to locate the EPROM U5 on the 8031 Pulse and Direction Interface Card (a more general map is shown earlier in the manual).

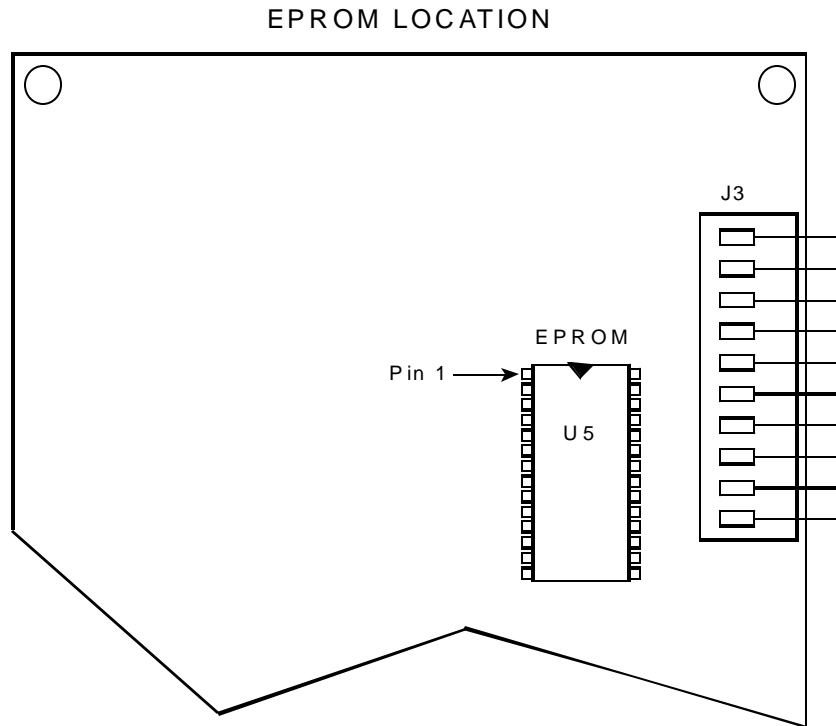

---

## Procedure

1. Turn off the power to the 8031 Pulse and Direction Interface Card.
2. Carefully remove the existing EPROM at site U5.
3. Locate pin 1 on the new EPROM. You will use pin 1 as a reference point.

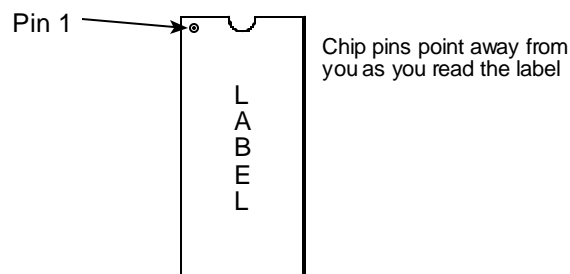

*Continued on next page*

# Installing the EPROM (continued)

---

## Procedure (continued)

4. Plug the new EPROM into the socket, with pin 1 on the EPROM aligned with pin 1 of the socket. Press the new EPROM firmly into the socket to ensure that it is fully seated.

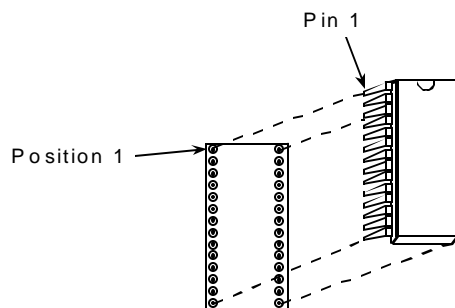

5. Inspect the EPROM pins to make sure that all pins are in the socket (and not bent over).

---

## EPROM Options

There are three EPROM options available with the 8031 Pulse and Direction Interface Card. These three EPROM options are used to set different scales for Switch 1 positions 1 and 2. The EPROMS are 64 K x 8 devices (27C512) with maximum access times of 120 ns.

<b>MTS Automation Programmed EPROM Part Number</b>
491395-01 — Standard pulse per revolution counts.
491395-02 — Optional pulse per revolution counts, 512 multiples.
491395-03 — Optional pulse per revolution counts, 1000 multiples.

Additional blank EPROMs can also be ordered from MTS Automation, part number 114817-32.

<b>Size</b>	<b>Vendor Part Number (Atmel)</b>	<b>MTS Automation Part Number</b>
64 K x 8	AT27C512-12DC	114817-32

# 8 TROUBLESHOOTING

---



## WARNING

Maintenance and troubleshooting must be performed only by qualified personnel and only after taking the necessary precautions to prevent injury or equipment damage in case of unexpected actuator movement or output signals.

The following procedures may require removing terminal strip J3.

- Turn off all ac and dc external power before attempting to remove the terminal strip.
- Take care to replace the terminal strip in the correct position, aligned on its pins, before applying power.

Failure to observe these precautions can cause equipment damage and a safety hazard.

---

## Introduction

If you experience a problem when using the 8031 Pulse and Direction Interface Card, use this troubleshooting guide to isolate the problem. This guide will help you determine whether the problem is internal (requiring replacement of the card) or external. Test equipment that would be useful includes a digital volt meter and an oscilloscope.

This chapter describes troubleshooting for the 8031 Pulse and Direction Interface Card only. For amplifier troubleshooting procedures, refer to your amplifier manual.

---

# LED Symptoms

---

**Symptoms** 8031 Pulse and Direction Interface Card LED is blinking red.

The LED blinks RED when the 8031 Pulse and Direction Interface Card detects an error.

**Blinking two times:** The LED blinks two times with a red color when an excess error is detected. An excess error occurs when the difference between the commanded and feedback positions is greater than 1920 pulses (168 degrees).

## Steps

1. This problem is often caused by a poorly tuned system. Adjust the values of Kp and Kd (see the chapter on tuning in this manual).
2. Power down the drive.
3. Verify motor and resolver wiring, and the amplifier set up.
4. Verify that the motor/amplifier combination can produce enough torque at the required speeds.

Disconnect the load and execute the motion. If this solves the problem, it is likely that the motor/amplifier cannot produce enough torque to keep the following error small enough. If this is the case, you will either need to modify the motion profile or increase the size of the motor and/or amplifier.

5. If the problem still exists, contact your supplier.

# Non-LED Symptoms

---

**Symptoms** Motor does not turn.

**Steps**

1. Ensure that the LED on the 8031 Pulse and Direction Interface Card is blinking green. If it is not blinking green, check the EPROM on the 8031 Pulse and Direction Interface Card. Ensure that the correct EPROM is installed in the correct orientation on the card. If possible, try using another identical EPROM.
2. Verify that the pulse and direction inputs are wired correctly. Use a voltmeter to verify that they toggle low and high when the pulse and direction commands are issued.
3. Verify the 8031 Pulse and Direction Interface Card tuning (see the chapter on tuning in this manual) and the amplifier tuning/set-up.
4. If the problem still exists, contact your supplier.

---

**Symptoms** Motor runs away.

**Steps**

1. Power down the drive.
2. Verify the cabling to the motor. Ensure that all motor and feedback wiring is correctly connected.
3. Check the EPROM on the 8031 Pulse and Direction Interface Card. Ensure that the correct EPROM is installed on the card. If possible, try using another identical EPROM.
4. If the problem still exists, contact your supplier.

---

**Symptoms** Motor runs sluggishly or is unstable.

**Steps**

1. Verify the 8031 Pulse and Direction Interface Card tuning (see the chapter on tuning in this manual).
  2. Ensure that the motor/amplifier combination has the power-torque capability to move the load in the required manner.
  3. If the problem still exists, contact your supplier.
-

# 9 8031 PULSE AND DIRECTION INTERFACE CARD SPECIFICATIONS

---



---

Parameter	Specification
<b>CPU</b>	
Type	80C32
Speed	16 MHz
Data Bus Width	8 bits
<b>Memory</b>	
System EPROM	64K bytes
System RAM	128 bytes (internal)
<b>EPROM</b>	
Size	512K bits (27C512)
Speed	120 ns (maximum)
Type	CMOS, 5 volt
<b>Digital Inputs</b>	
Pulse and Direction (CW/CCW)	
Voltage Sense	active high or active low
Current Sense	sinking or sourcing
Maximum Pulse Rate	500 kHz
Minimum Pulse Width	1 $\mu$ s
Propagation Delay	200 $\mu$ s maximum
Input Voltage	5 to 30 Vdc = On 1 Vdc = Off
Input Current	10 mA maximum
Isolation	1500 V minimum
<b>Digital Output</b>	
Fault	
Voltage Sense	active high or active low
Current Sense	sinking or sourcing
Propagation Delay	25 $\mu$ s maximum
Leakage Current	100 nA maximum
Output Current	15 mA minimum
Isolation	1500 V minimum
<b>Servo Output</b>	
Type	Analog Voltage
Resolution	12 bits
Range	$\pm$ 10 V single-ended
Load Resistance	2K $\Omega$ minimum
<b>Terminal Wire Range</b>	
J3	16 to 24 AWG, strip length .25 inches
<b>Environment</b>	
Temperature	0 to 45 degrees C ambient 32 to 113 degrees F ambient
Humidity	10 to 90%, noncondensing
<b>Overall Dimensions</b>	
Length	5.1 inches
Width	4.5 inches

*Specifications are subject to change without notice. Contact MTS Automation for verification of specifications critical to your needs.*

---

# 10 RUNNING WITH MPA-03SL OR MPA-06SL AMPLIFIERS

This chapter explains how the MPA-03SL and MPA-06SL amplifiers are used with the 8031 Pulse and Direction Interface Card.

The MPA-03SL or MPA-06SL amplifiers must be configured properly to operate correctly with the 8031 Pulse and Direction Interface Card. See the *MPA-03/06SL Brushless Servo Amplifier Manual* for resolver, motor, and power cabling.

These amplifiers can commutate four-pole, six-pole, eight-pole, and brush motors. JP3 and JP4 on the amplifier card configure the amplifier for the motor type to be run. The following figure shows the location of jumpers JP3 and JP4. JP3 and JP4 are located on the amplifier card underneath the 8031 Pulse and Direction Interface Card.

**! WARNING**

Never change these jumpers with the power on.

## Jumper Locations

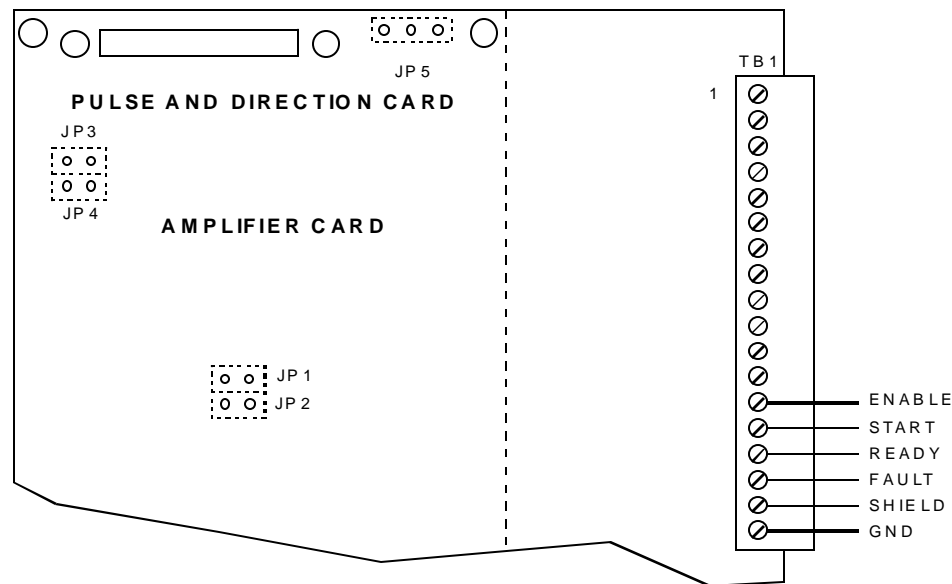

JP3	JP4	Motor Type
OUT	IN	4-Pole
IN	OUT	6-Pole
IN	IN	8-Pole
OUT	OUT	Brush

Continued on next page

## Running with MPA-03SL or MPA-06SL Amplifiers (continued)

---

Set JP5 on the amplifier to the “N” setting when running the 8031 Pulse and Direction Interface Card in the torque mode, or use the non-N setting when running it in the velocity mode. When running in the torque mode, the SIG, BAL, RESP, and CUR pots are not used and have no effect on system performance. When running in the velocity mode, set these pots according to the amplifier manual. These jumper settings are indicated by a black box (v) below.

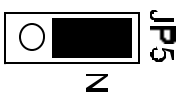
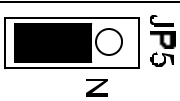
JP5	Mode
	Torque
	Velocity

JP1 and JP2 select the mode in which the R-D converter operates .

JP1	JP2	Mode
OUT	IN	12 bit
IN	OUT	14 bit

---

# TB1 Input/Output Pins

---

TB1 contains the resolver feedback signals, start and enable inputs, and the ready and fault outputs.

<b>TB1 Start and Enable Input Specifications (Active Low Inputs)</b>	
Input ON Voltage	3.0 Vdc maximum.
Input ON Current	3.0 mA maximum (current out from TB1).
Input OFF Voltage	11 volts to 30 volts. Input is biased to 11.5 Vdc. Leaving the inputs open turns the inputs off.
Input OFF Current	0 mA @ 11.5 Vdc, 7.0 mA @ 30 Vdc.

<b>TB1 Ready and Fault Output Specifications (Open Collector, Active Low Outputs)</b>	
Output ON Voltage	0.5 Vdc maximum.
Output ON SINK Current	50 mA maximum.
Output OFF Voltage	30 Vdc volts maximum.
Output OFF Leakage Current	100 $\mu$ A.

<b>Amplifier Signal Definitions</b>	
START	The 8031 Pulse and Direction Interface Card monitors this pin to determine if it should follow the input pulse stream. If this input is OFF (high or open), the 8031 Pulse and Direction Interface Card will just hold position and ignore the input pulses. When ON (low), the 8031 Pulse and Direction Interface Card will follow the incoming pulses.
ENABLE	This is an input to the amplifier which is used to enable the amplifier circuits. ENABLE OFF puts the amplifier and the 8031 Pulse and Direction Interface Card in a RESET condition.
READY	This output is active (low) whenever the 8031 Pulse and Direction Interface Card is following the input pulse stream.
FAULT	This is an output from the amplifier that indicates that at least one of the four amplifier FAULT conditions has occurred. (The 8031 Pulse and Direction Interface Card FAULT does <u>not</u> affect this output.)

---

*Continued on next page*

# TB1 Input/Output Pins (continued)

## TB1 Input Circuitry

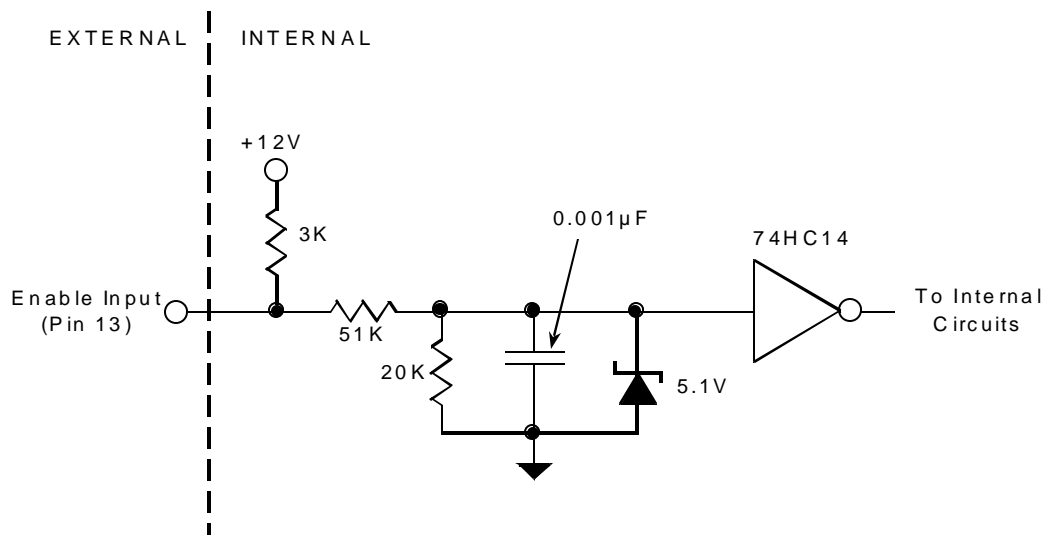
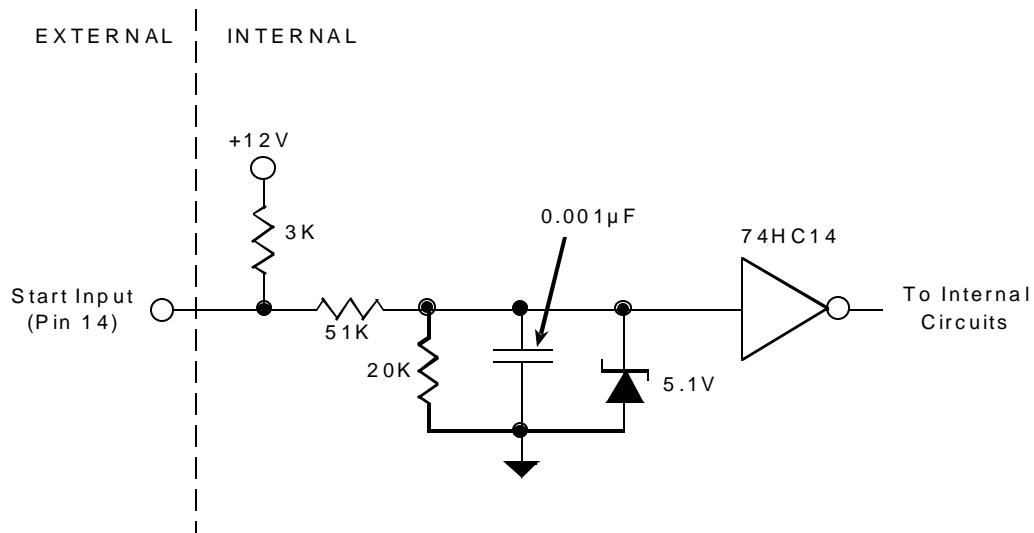

*Continued on next page*

# TB1 Input/Output Pins (continued)

## TB1 Output Circuitry

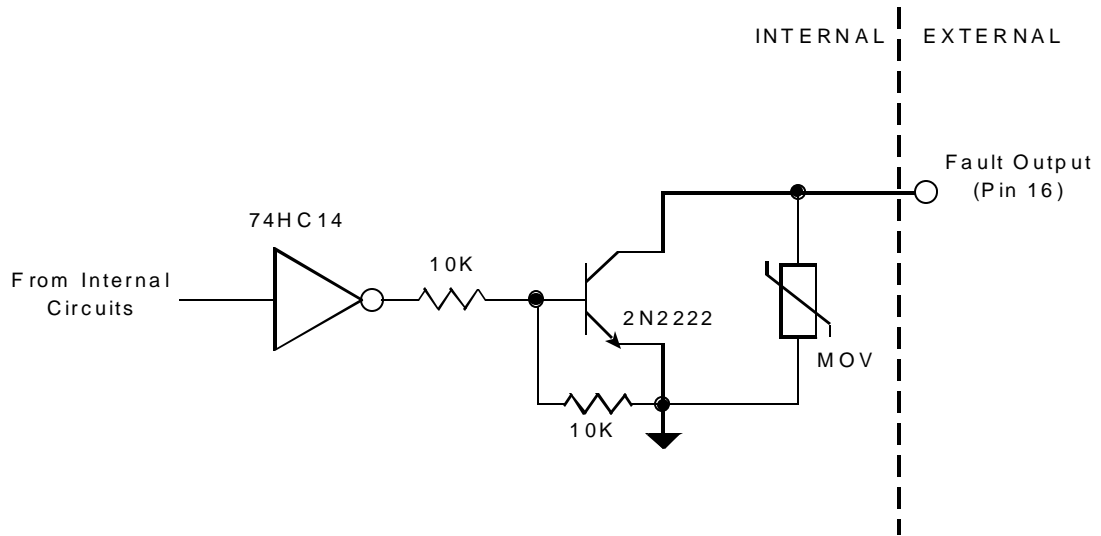
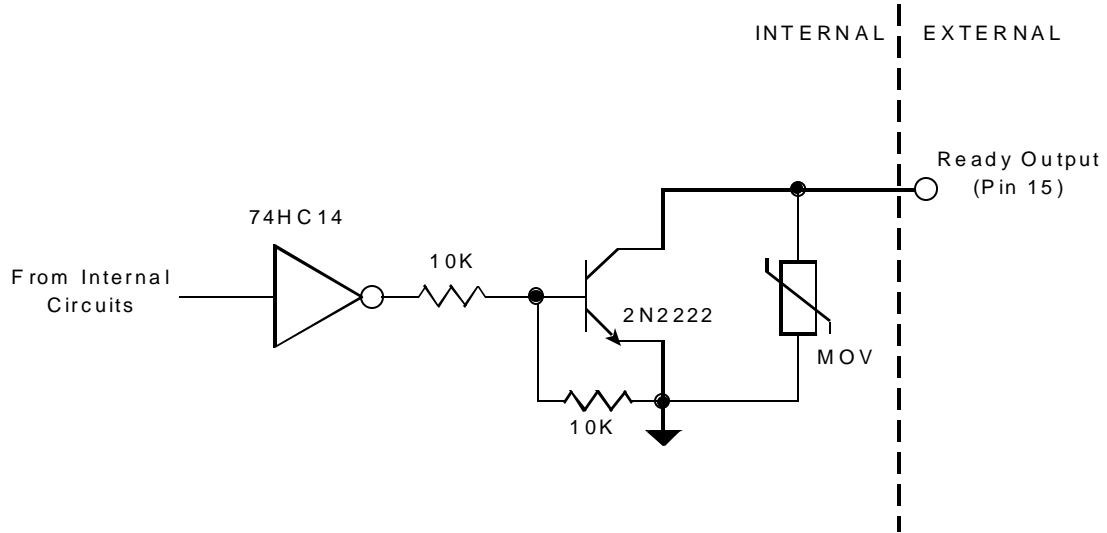

*Continued on next page*

# TB1 Input/Output Pins (continued)

## Typical External Connections to TB1

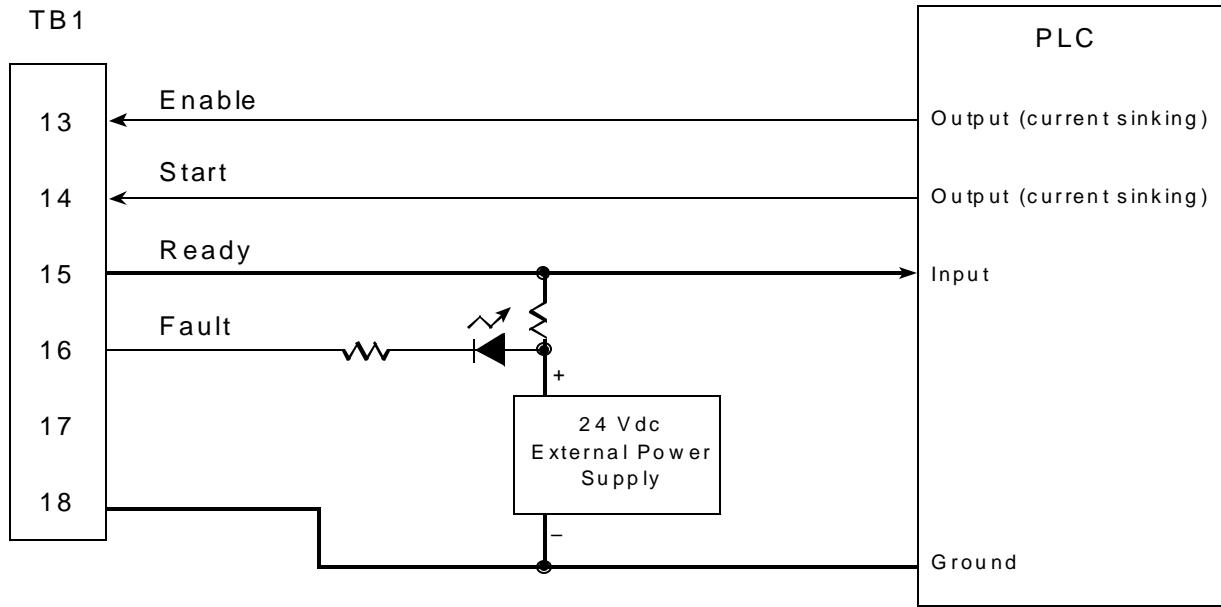

Typical wire size for digital I/O is 16–24 gauge.

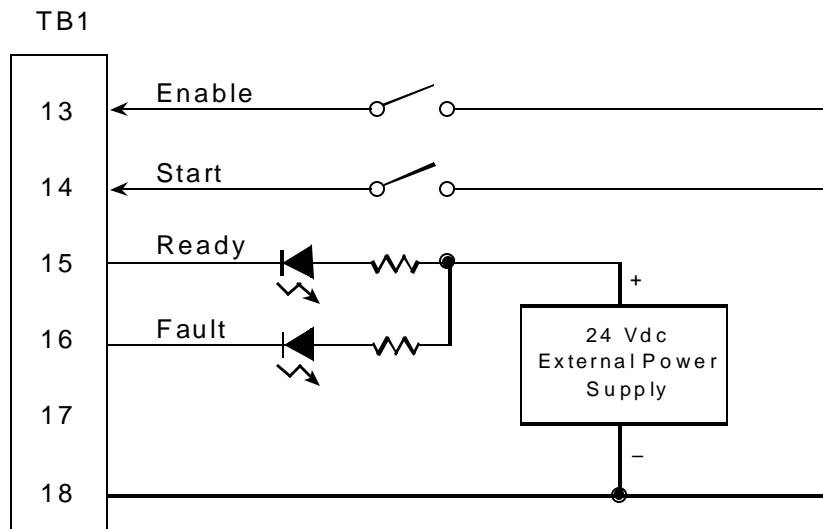

# 11 RUNNING WITH MPA-230 OR MPA-460 ANF3/8031 BRUSHLESS SERVO AMPLIFIERS

---

This chapter explains how the MPA-230 or MPA-460 ANF3/8031 amplifiers are used with the 8031 Pulse and Direction Interface Card.

The MPA-230 or MPA-460 ANF3/8031 amplifiers must be configured properly to operate correctly with the 8031 Pulse and Direction Interface Card. See the *Brushless Servo Amplifiers MPA-230 or MPA-460 ANF3/8031 Manual* for resolver, motor, and power cabling.

These amplifiers can commutate four-pole, six-pole, eight-pole, and brush motors. The following figure shows the location of switches S2 and S4 and jumper JR1 located on the amplifier card underneath the 8031 Pulse and Direction Interface Card.



Never change these switches or jumpers with the power on.

# Switch and Jumper Locations

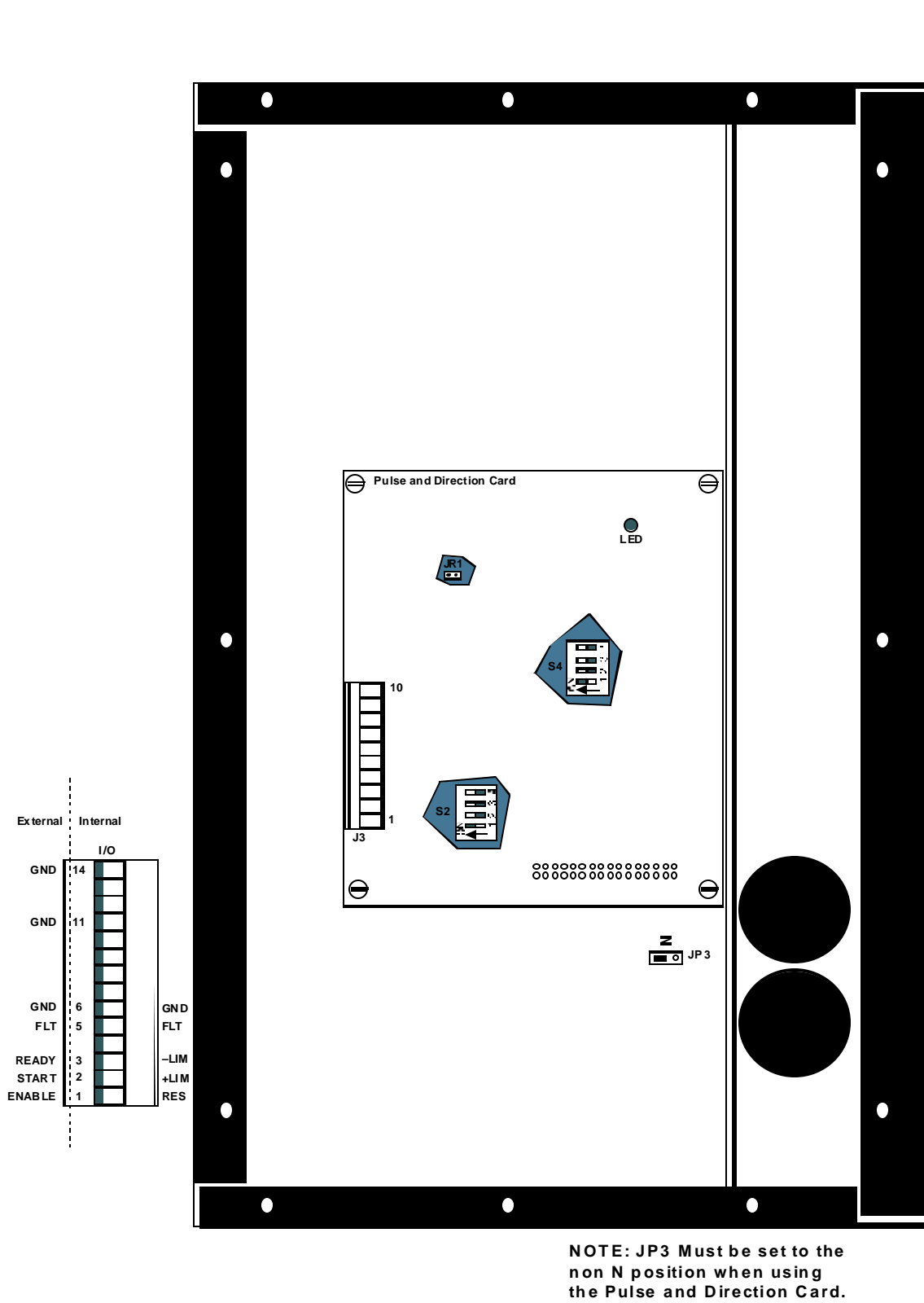

Continued on next page

# Input/Output Pins

---

The Input/Output connector contains the resolver feedback signals, start and enable inputs, and the ready and fault outputs.

<b>Start and Enable Input Specifications (Active Low Inputs)</b>	
Input ON Voltage	3.0 Vdc maximum.
Input ON Current	3.0 mA maximum (current out).
Input OFF Voltage	11 volts to 30 volts. Input is biased to 11.5 Vdc. Leaving the inputs open turns the inputs off.
Input OFF Current	0 mA @ 11.5 Vdc, 7.0 mA @ 30 Vdc.

<b>Ready and Fault Output Specifications (Open Collector, Active Low Outputs)</b>	
Output ON Voltage	0.5 Vdc maximum.
Output ON SINK Current	50 mA maximum.
Output OFF Voltage	30 Vdc volts maximum.
Output OFF Leakage Current	100 $\mu$ A.

<b>Amplifier Signal Definitions</b>	
START	The 8031 Pulse and Direction Interface Card monitors this pin to determine if it should follow the input pulse stream. If this input is OFF (high or open), the 8031 Pulse and Direction Interface Card will just hold position and ignore the input pulses. When ON (low), the 8031 Pulse and Direction Interface Card will follow the incoming pulses.
ENABLE	This is an input to the amplifier which is used to enable the amplifier circuits. ENABLE OFF puts the amplifier and the 8031 Pulse and Direction Interface Card in a RESET condition.
READY	This input is active (low) whenever the 8031 Pulse and Direction Interface Card is following the input pulse stream.
FAULT	This is an output from the amplifier that indicates that at least one of the four amplifier FAULT conditions has occurred. (The 8031 Pulse and Direction Interface Card FAULT does <u>not</u> affect this output.)

---

*Continued on next page*

# Input/Output Pins (continued)

## Input Circuitry

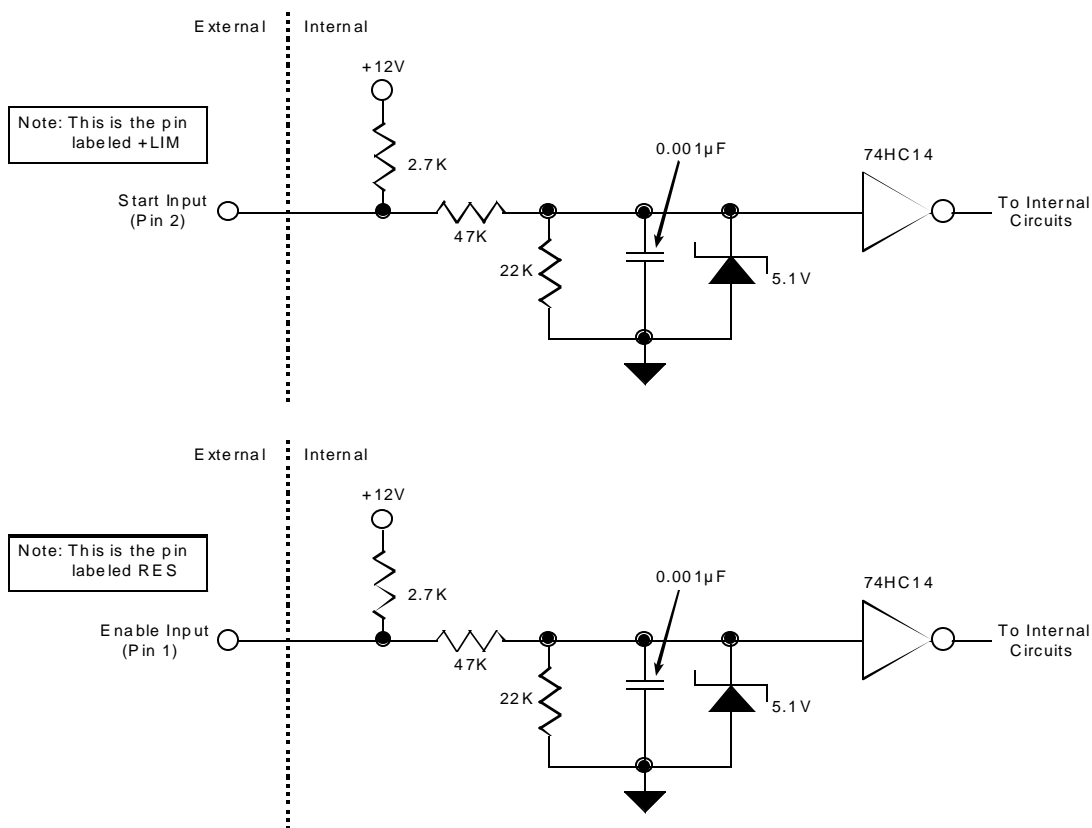

Continued on next page

# Input/Output Pins (continued)

## Output Circuitry

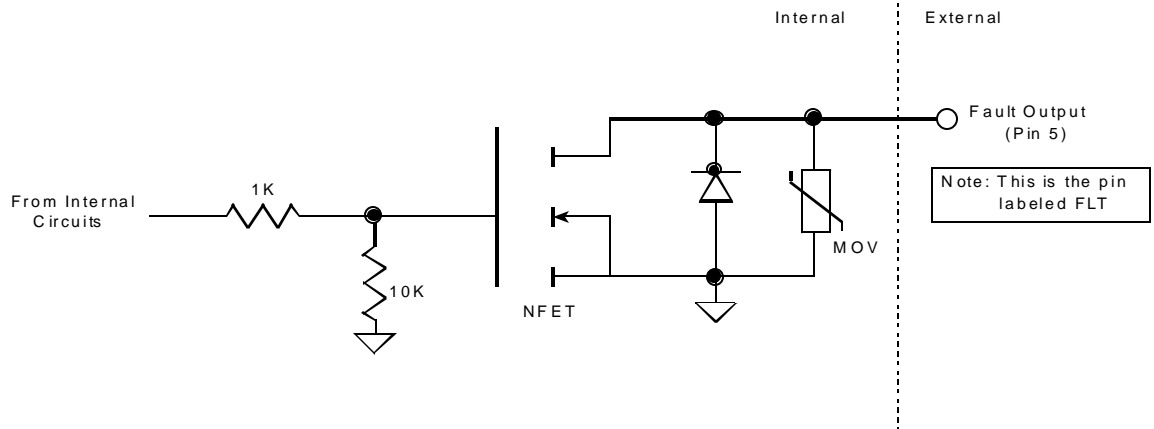
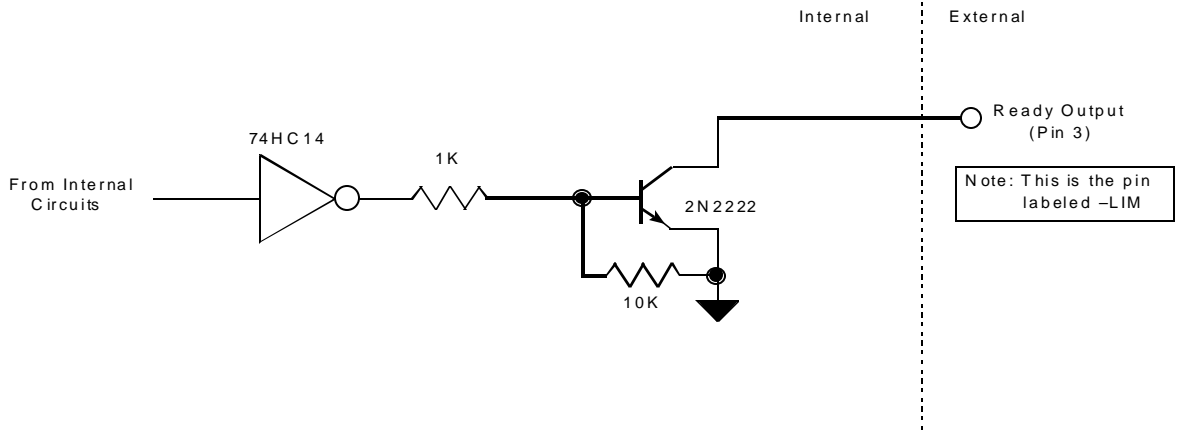

*Continued on next page*

# Input/Output Pins (continued)

## Typical External Connections to Input/Output Pins

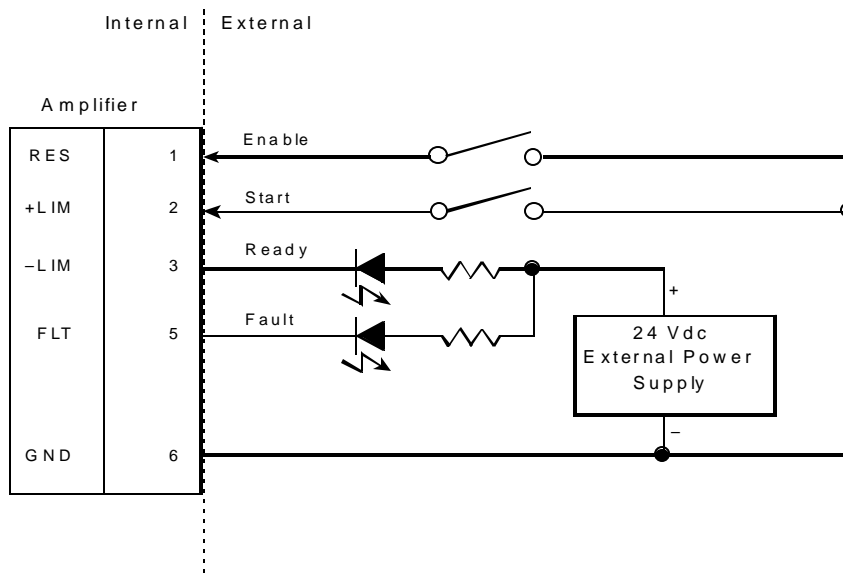
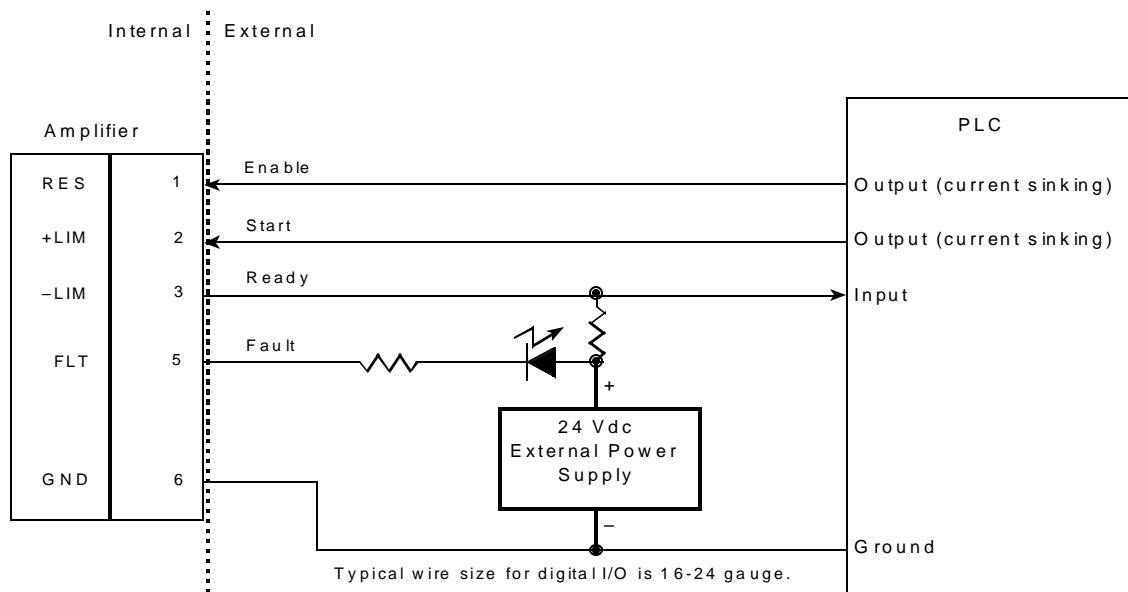

## **Addendum for the 8031 Pulse & Direction Card Installation Manual (P/N: 150645-00 Rev. C)**

In March 1998, a new EPROM (P/N: 491395-03) was released for the 8031 Pulse & Direction board. The line counts for this EPROM are 1000, 2000, 3000, and 4000 lines per revolution. The following changes will be made in the next printing of the manual.

*The first two tables on page 4-2 should be replaced with the following table:*

<b>POSN1</b>	<b>POSN2</b>	<b>Pulses Per Revolution P/N 491395-01</b>	<b>Pulses Per Revolution P/N 491395-02</b>	<b>Pulses Per Revolution P/N 491395-03</b>
OFF	OFF	400*	512*	1000*
OFF	ON	1000	1024	2000
ON	OFF	2000	2048	3000
ON	ON	4000	4096	4000
* Factory Setting				

---

*Replace the first table on page 7-3 with the following table:*

<b>MTS Automation Programmed EPROM Part Number</b>
491395-01 — Standard pulse per revolution counts.
491395-02 — Optional pulse per revolution counts, 512 multiples.
491395-03 — Optional pulse per revolution counts, 1000 multiples.

Replace page 3-4 with the following information.

J3 can use an external 5 – 30 Vdc power source if isolated inputs are required. Note that inputs on J3 can be either differential, current sinking or sourcing.

### Typical External Connections to J3 (Set Up as Differential)

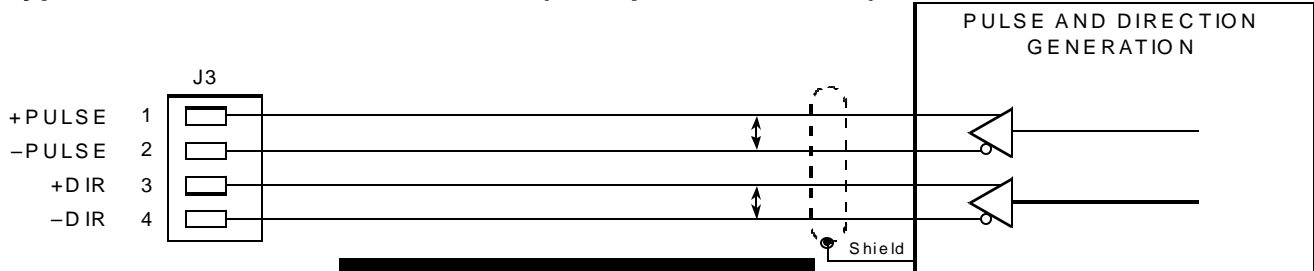

**NOTE**

Twisted pair with overall foil and braid shielded wire recommended.

### Typical External Connections to J3 (Set Up as Current Sinking)

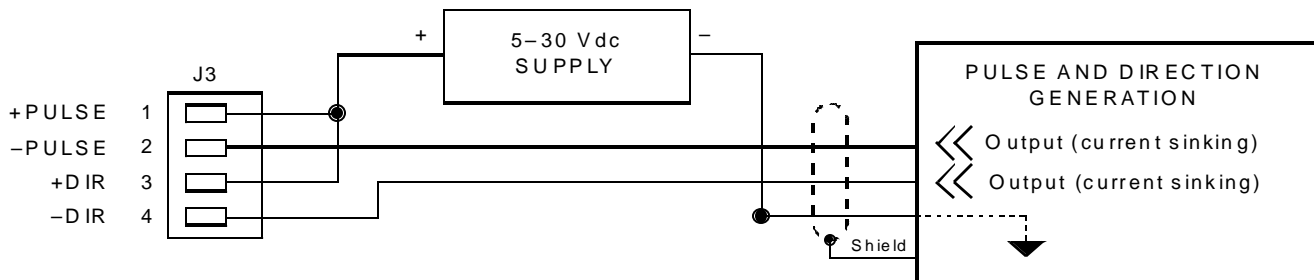

Typical wire size for digital inputs is 16 – 24 gauge.

**CAUTION**

Polarity of input is critical. Lead reversal can damage inputs.

**NOTE**

Open collector outputs may require an external pull-up resistor.

### Typical External Connections to J3 (Set Up as Current Sourcing)

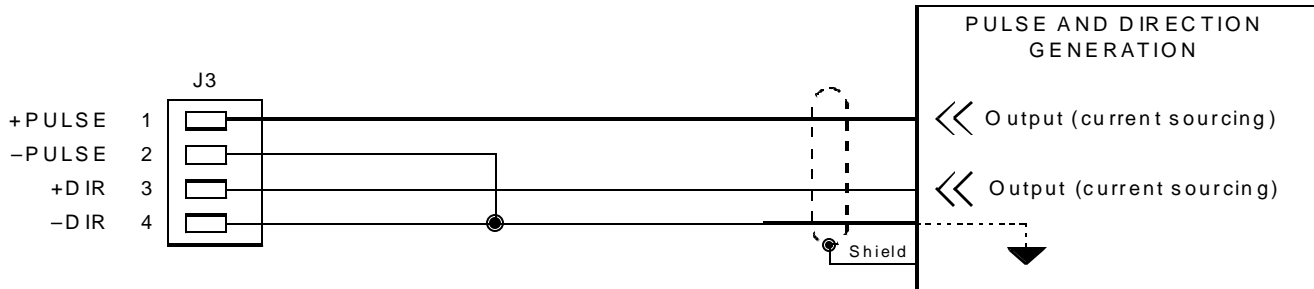

Typical wire size for digital inputs is 16 – 24 gauge.

**CAUTION**

Polarity of input is critical. Lead reversal can damage inputs.

