

# XDC

---

## Remote Operator Interface Kit Installation Instructions

**Custom Servo Motors Inc.**  
A Subsidiary of MTS Systems Corporation

2121 Bridge Street  
New Ulm, MN 56073  
Telephone: 507-354-1616  
Fax: 507-354-1611

1197

150616-00F

©Custom Servo Motors Inc. 1997

10/97

# XDC Remote Operator Interface Kit Installation Instructions

## Introduction

The Motion Plus Remote Operator Interface Kit is designed to provide remote access to the XDC Series of direct digital controllers. The Kit allows operation of the controller unit from a location up to 250 feet away.

In addition to this manual, each kit contains the following items:

- One keypad/LCD display assembly
- One bag containing
  - Four slotted set screws, 6-32 size, 1 in. long
  - Four nuts, 6-32 size
  - One label set (2 pieces)
  - One FASTON receptacle

### CAUTION

This kit contains static-sensitive integrated circuit components. To avoid static damage, take the following precautions when handling these parts: Do not remove a part from the anti-static bag until you are ready to install that part. Avoid touching circuit components or conductive paths on the parts.

This manual explains the basic procedure for mounting and cabling the assembled remote unit (Procedure A) and for assembling and cabling the optional hand-held unit (Procedure B).

FASTON is a trademark of AMP, Inc.

**Procedure A. (Panel-mounted unit only) Mounting and cabling the assembled remote unit.**

1. Prepare the panel where the remote unit will be mounted. Cut a rectangular hole (4 in. by 7-3/4 in.) and drill four holes (0.169 in. dia) in the panel. Dimensions are shown in Figure 1. A template for positioning these holes is included at the end of this manual.

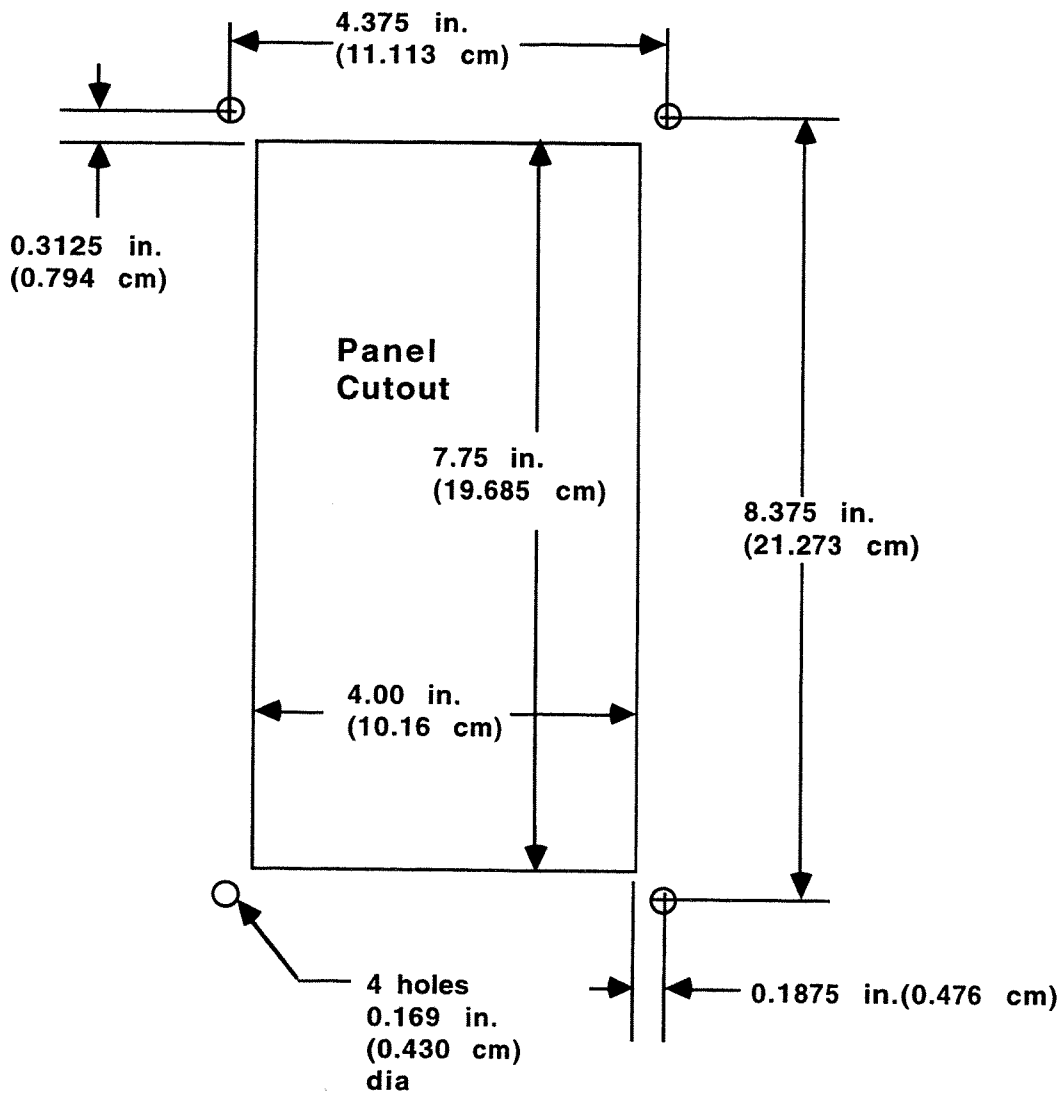

Figure 1. Panel Mounting Dimensions

2. Thread the four slotted setscrews provided into the plastic housing of the remote unit. Make sure the slotted end of each setscrew is out. Screw these in by hand, taking care not to overtighten. Refer to Figure 2.

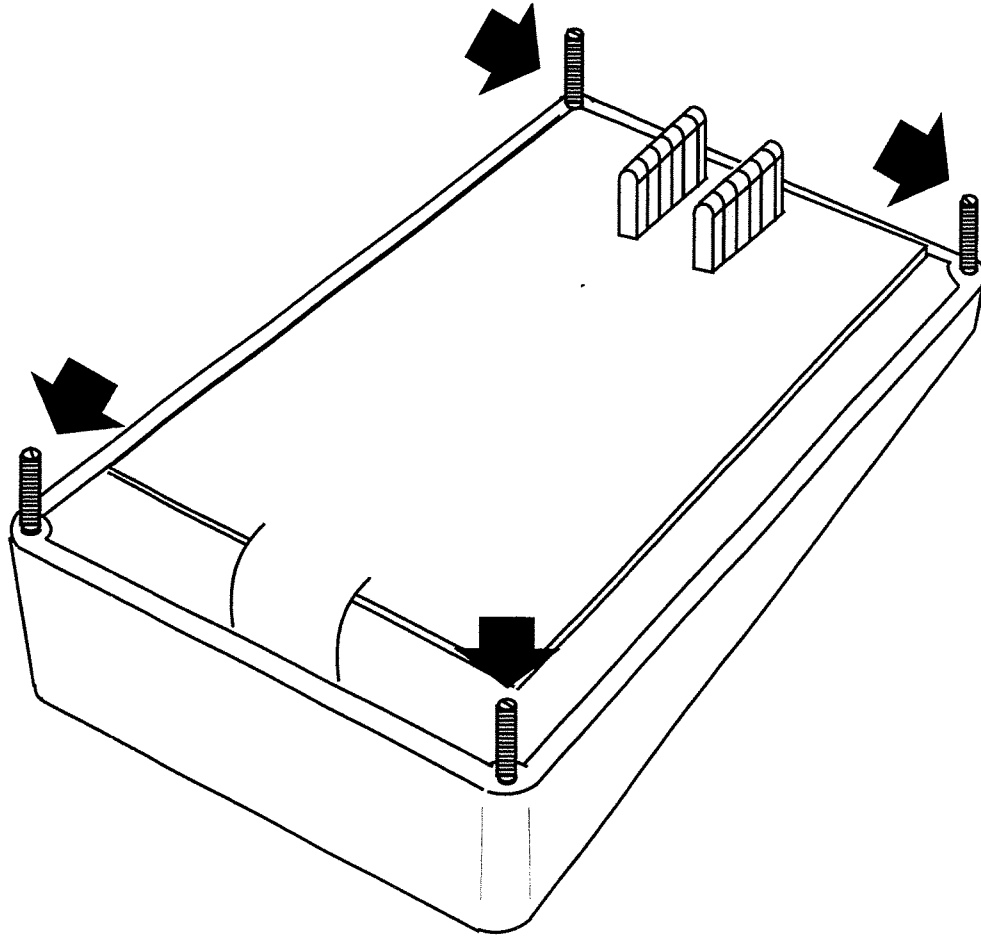

Figure 2.

3. Position the remote unit in the panel cutout, so that the four setscrews project through the four drilled holes in the panel, as shown in Figure 3. Use the four nuts provided to secure the remote unit, taking care not to overtighten. The gasket will seal without undue pressure.

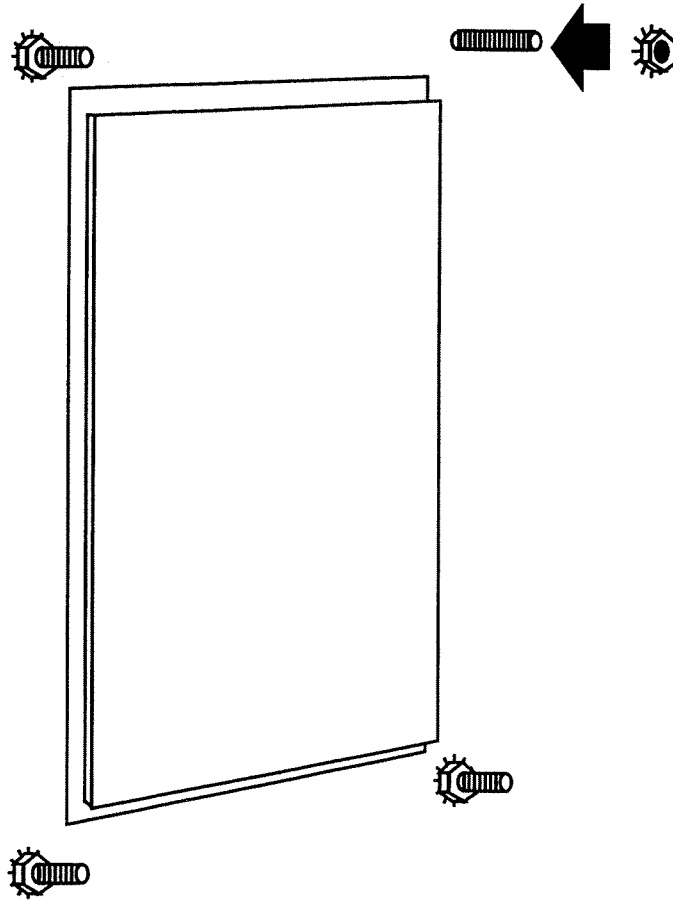

Figure 3.

4. **For XDC 700 or XDC 710:**  
 A connector is already plugged into the receptacle J20 on the remote processor board. Unplug this connector. Use it with the wire specified in Table 1 to make a cable for connecting the remote operator interface to the XDC 700 or XDC 710 unit. Be sure the shield wire is grounded at the XDC end only. Refer to Figure 4 (for internal XDC power) or 5 (for external power).

Table 1. Cable Specifications

Distance	Cable
up to 50 ft	industrial wire, 14-28 AWG, two twisted pairs with one overall shield
50 to 250 ft	Belden 8102 or equivalent
over 250 ft	Consult Custom Servo Motors, Inc.

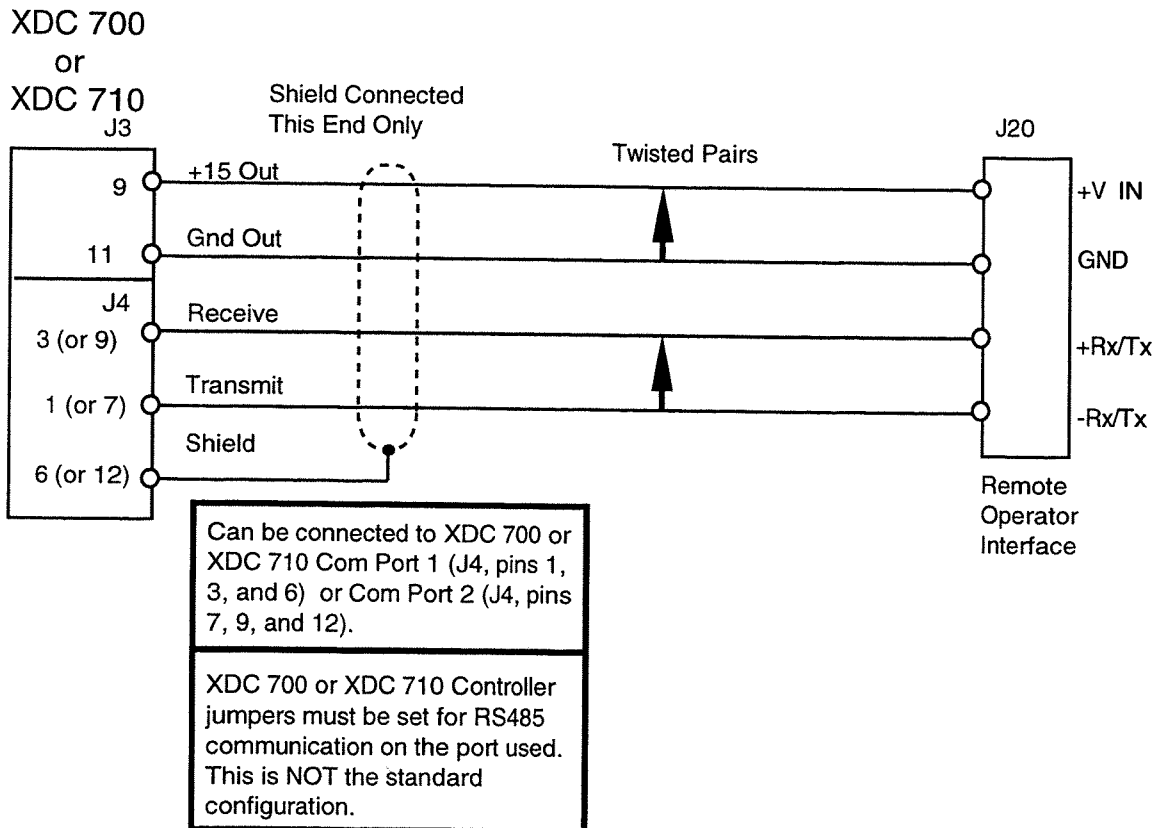

Figure 4. Cable Configuration—XDC 700 or XDC 710 to Remote Interface (Internal Power)

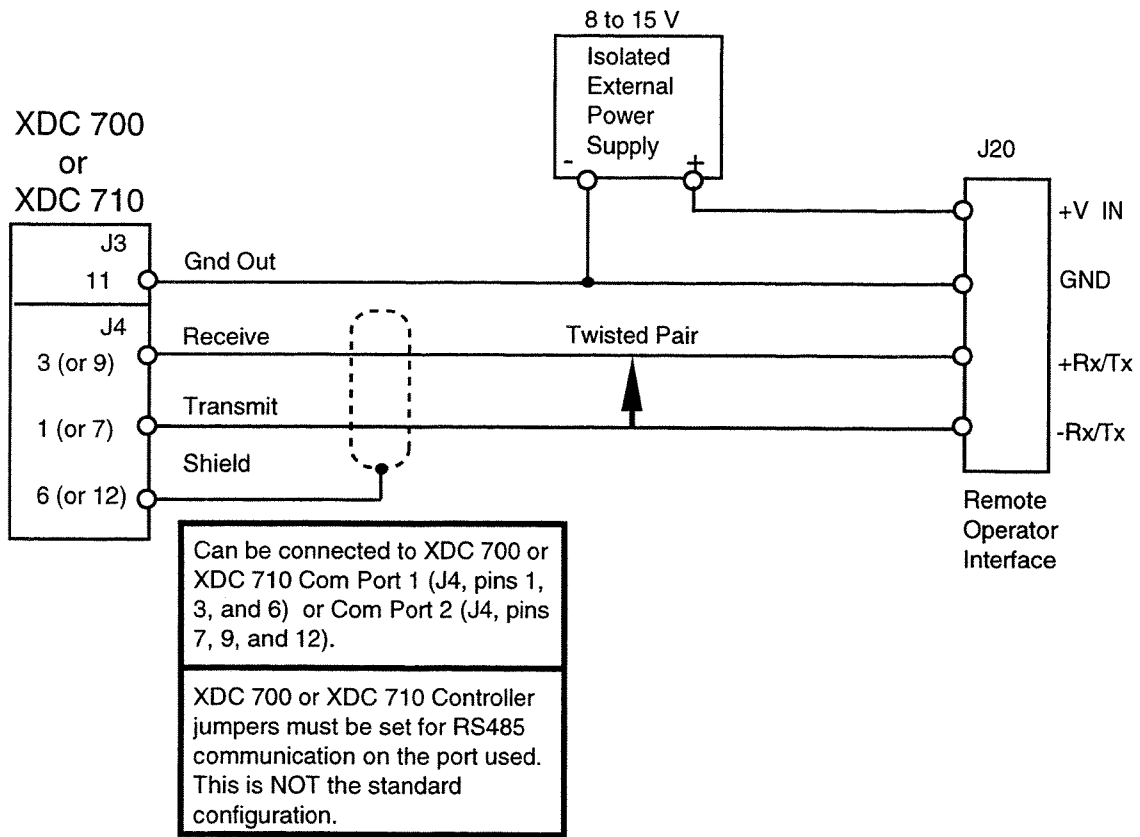

Figure 5. Cable Configuration—XDC 700 or XDC 710 to Remote Interface (External Power)

**⚠ CAUTION**

Power wiring can cause noise on nearby digital circuits. Do not run the remote interface cable close to power wiring. Leave at least 12 inches between this cable and power wiring.

4. **For XDC 720:**  
 A standard cable is available. The part number is 520789-01 for a 5-foot length or 520789-04 for a 20-foot length. For longer cables, contact Custom Servo Motors.

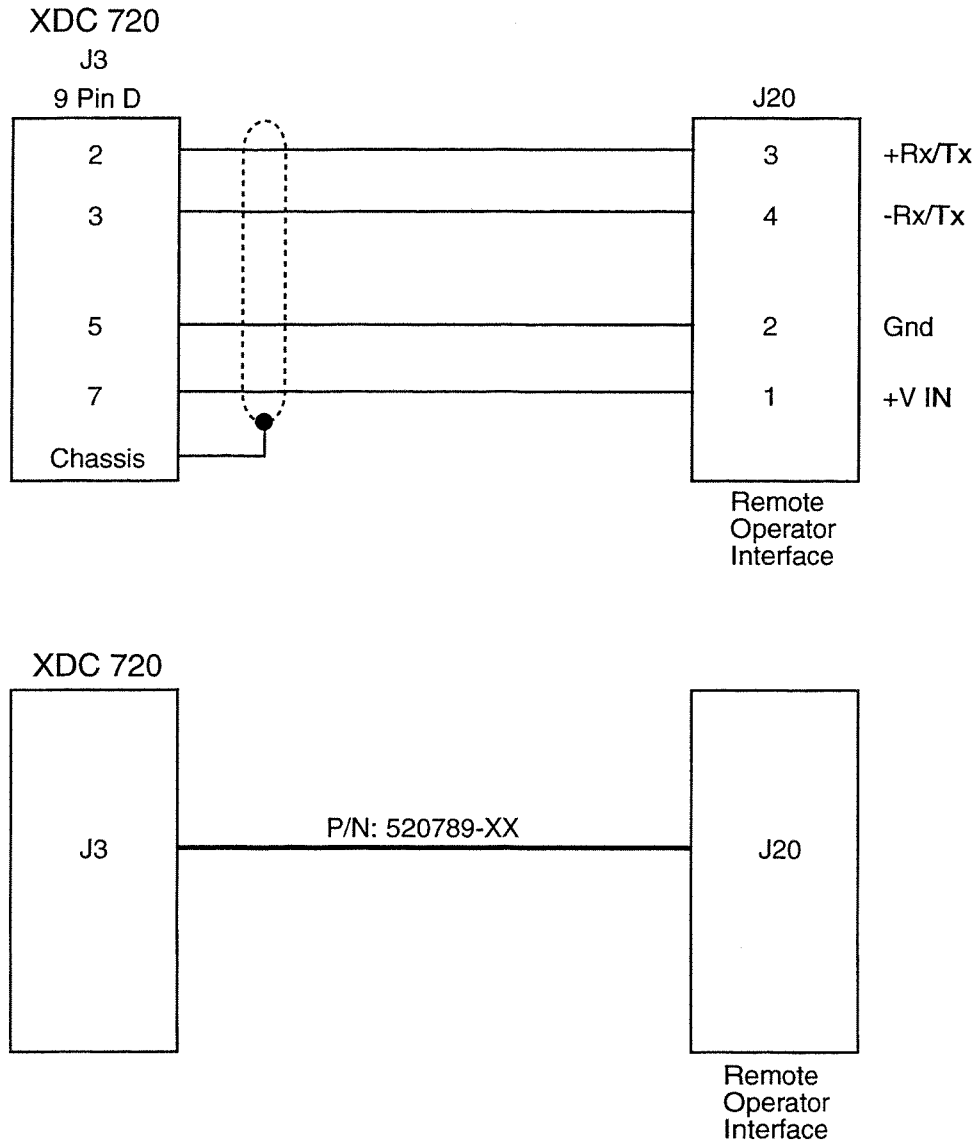

Figure 6. Cable Configurations—XDC 720 to Remote Interface (Internal Power)

## NOTE

The following connection is recommended in cases where the keypad will be operated near high potential static charges.

5. Find the FASTON tab located at the base of a standoff in the lower right corner of the keypad (as seen from the back). Use the FASTON receptacle provided in this kit to connect a ground wire (18 AWG, green recommended) to this FASTON tab. Run the wire to the chassis ground for your system, as shown in Figure 6. This provides a ground path from the keypad metal plate to the chassis ground.

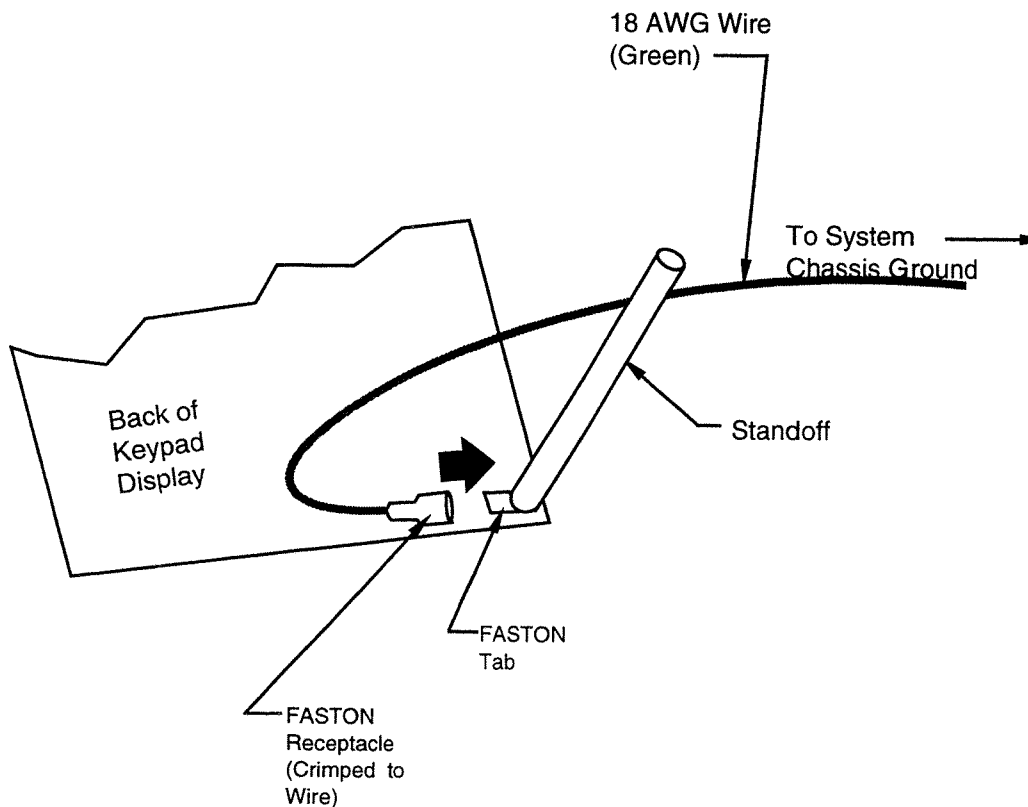

Figure 6.

FASTON is a trademark of AMP, Inc.

6. Select the appropriate label from the label set and attach it to the remote interface assembly as shown in Figure 7.

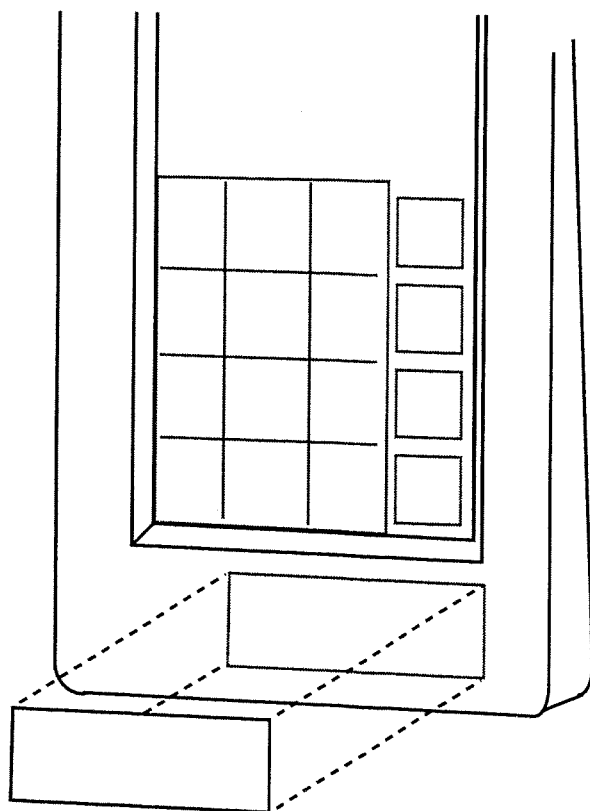

Figure 7.

7. If necessary, adjust the LCD view angle (See the Troubleshooting section of this manual.)

**Procedure B. (Optional hand-held unit only) Enclosing and cabling the assembled remote unit.**

1. Specifications for the cable are shown earlier in Table 1. The cable connects to J20 on the remote processor board. A connector is already plugged into the receptacle J20 on the remote processor board. Unplug this connector before assembling the unit.
2. Unpack the back cover and the strain relief assembly. Disassemble the strain relief assembly into its three parts: the strain relief, the bushing, and the nut. Refer to Figure 8.

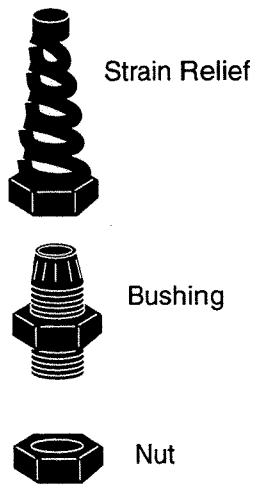

Figure 8.

3. Refer to Figure 9. Thread the cable through the strain relief (A), the bushing (B), the hole in the back cover (C), and the nut (D). Assemble the nut, bushing, and strain relief, leaving about 2 to 3 inches of cable inside the back cover. Strip the cable for wiring to the J20 connector (E).

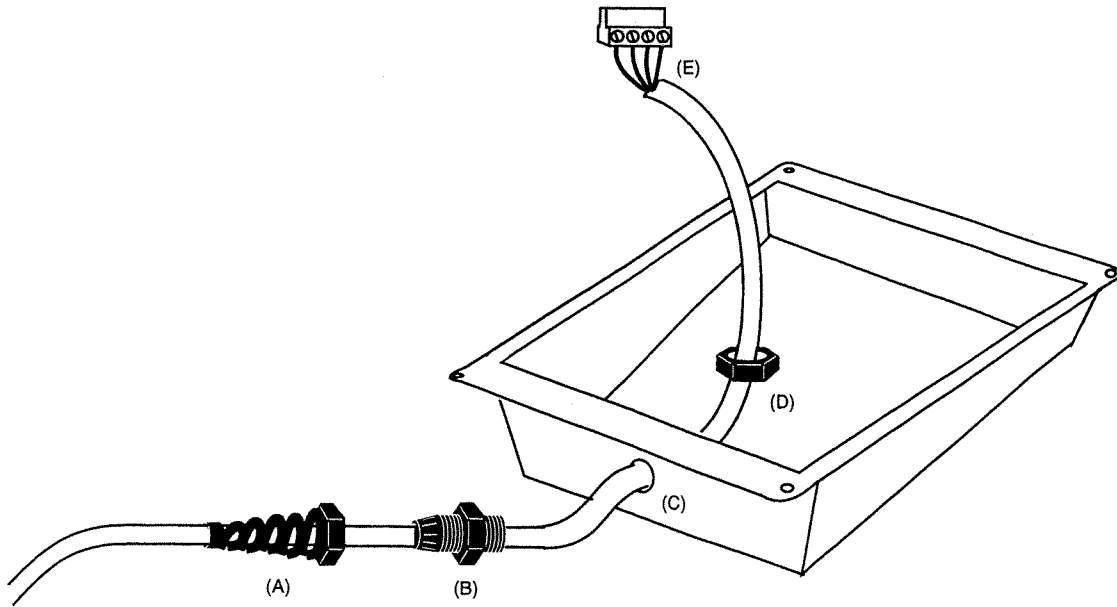

Figure 9.

4. For cable configurations, refer to the earlier Figure 4 (for internal XDC power) or 5 (for external power). Be sure the shield wire is grounded at the XDC end only. Wire the cable to the J20 connector. Plug the connector into J20 on the remote processor board.
5. If necessary, adjust the LCD view angle (See the Troubleshooting section of this manual).

6. Refer to Figure 10. Carefully assemble the back cover to the remote assembly, using the four black Phillips head screws provided (Do not use the setscrews or locknuts). Do not overtighten the screws. The gasket will seal without undue pressure.

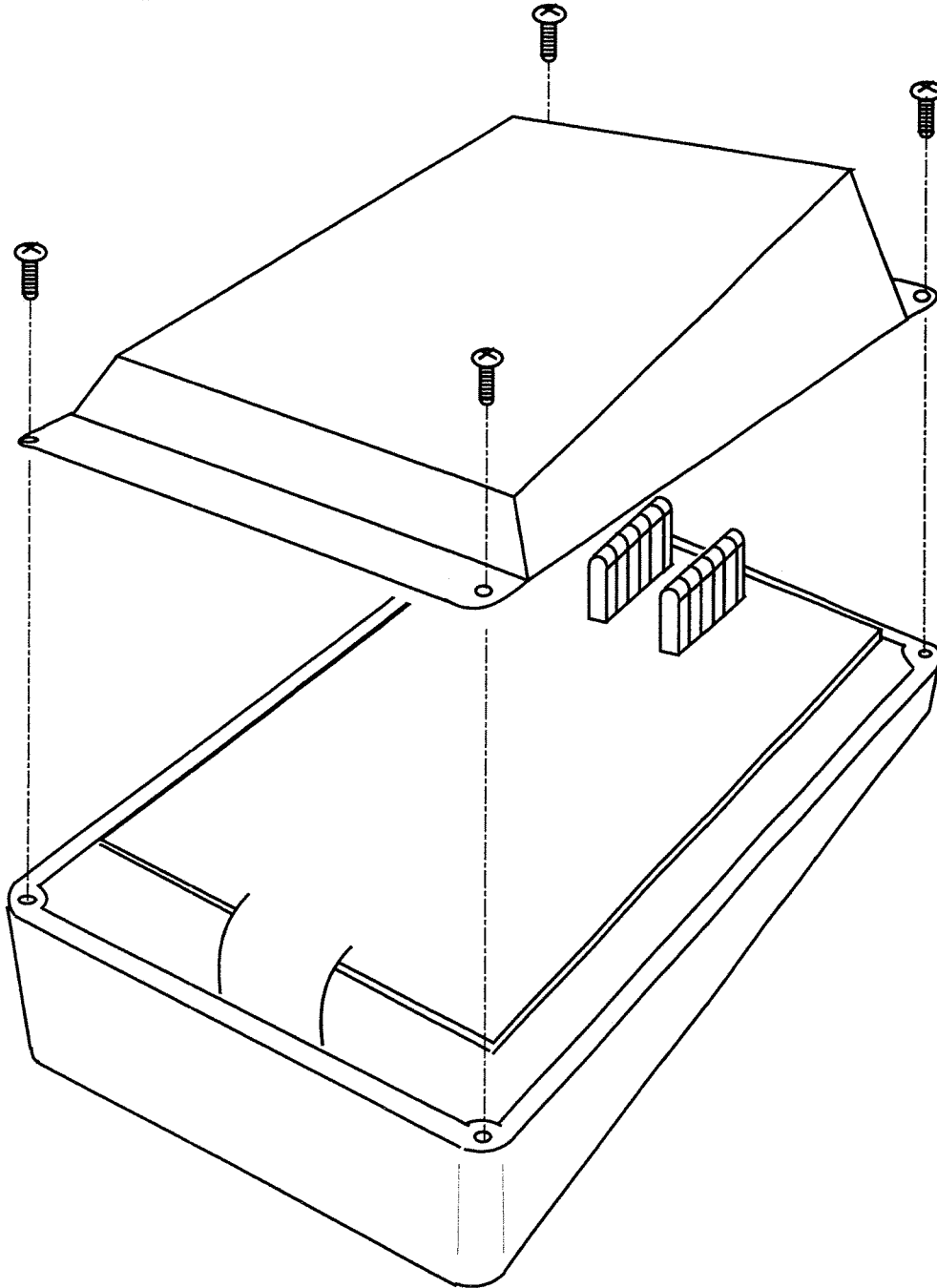

Figure 10.

7. Select the appropriate label from the label set and attach it to the remote interface assembly as shown in earlier Figure 7.

## Troubleshooting

### **WARNING**

Some troubleshooting steps involve potential shock hazard. Electrical power measurement should be performed only by qualified personnel taking the necessary precautions to prevent injury or equipment damage.

**Symptom** The remote LCD is blank (no black dots). The remote Power and Fault LEDs are off.

### **NOTE**

For this problem, it is assumed that no application software is running on the Controller at this time. The normal condition with no application program running is black dots on rows one and three only on the remote LCD and both remote LEDs off.

### **Steps**

1. Check the cabling.
2. Make sure there is power to the remote interface.
3. Check the viewing angle at the remote interface by taking the following steps:
  - a. Observe the LCD screen.
  - b. If the screen is blank, adjust the viewing angle potentiometer on the remote interface by turning it carefully with a non-metallic alignment tool. Notice that this potentiometer is limited to less than one full turn of adjustment. Do not force it or turn it beyond its normal stops.



## CAUTION

Do not use a metal screwdriver to adjust the LCD viewing angle potentiometer. A plastic adjustment tool is recommended. Using a metal screwdriver can cause a short-circuit and damage the Remote Interface.

---

**Symptom** The remote keypad and LCD screen are not operational.

### Steps

1. Check the cabling.
2. Make sure the XDC serial port is set for RS485 operation.
3. Make sure the application program addresses the correct serial port.
4. Make sure the application program addresses this remote interface.

---

**Symptom** The remote LCD has black dots on the entire screen (all four rows have black dots). The remote Power and Fault LEDs are off.

## NOTE

For this problem, it is assumed that no application software is running on the Controller at this time. The normal condition with no application program running is black dots on rows one and three only on the remote LCD and both remote LEDs off.

## Steps

1. Check the viewing angle of the remote interface by taking the following steps:
  - a. Observe the LCD screen.
  - b. Adjust the viewing angle potentiometer on the remote interface by turning it carefully with a non-metallic alignment tool. Notice that this potentiometer is limited to less than one full turn of adjustment. Do not force it beyond its normal stops.

## Specifications

Parameter	Specification
Overall Dimensions (fully assembled with Keypad/LCD)	Height: 8.75 in. (22.2 cm) Width: 4.75 in. (12.1 cm) Depth: 3.00 in. (7.6 cm) Depth with back cover: 2.57 in.(6.5 cm) maximum
Voltage Requirement	8 to 15 Vdc
Power Consumption	6 W maximum
Wire Type	Belden 8102 or equivalent
Communication	RS485
Baud rate	19.2K baud standard (selectable to 38.4K baud)
Operating Environment	0° to 50°C (32° to 122°F) ambient operating temperature Up to 95% humidity, noncondensing
Operating Distance	up to 250 ft

Specifications are subject to change without notice. Contact Custom Servo Motors Inc. for verification of specifications critical to your needs.

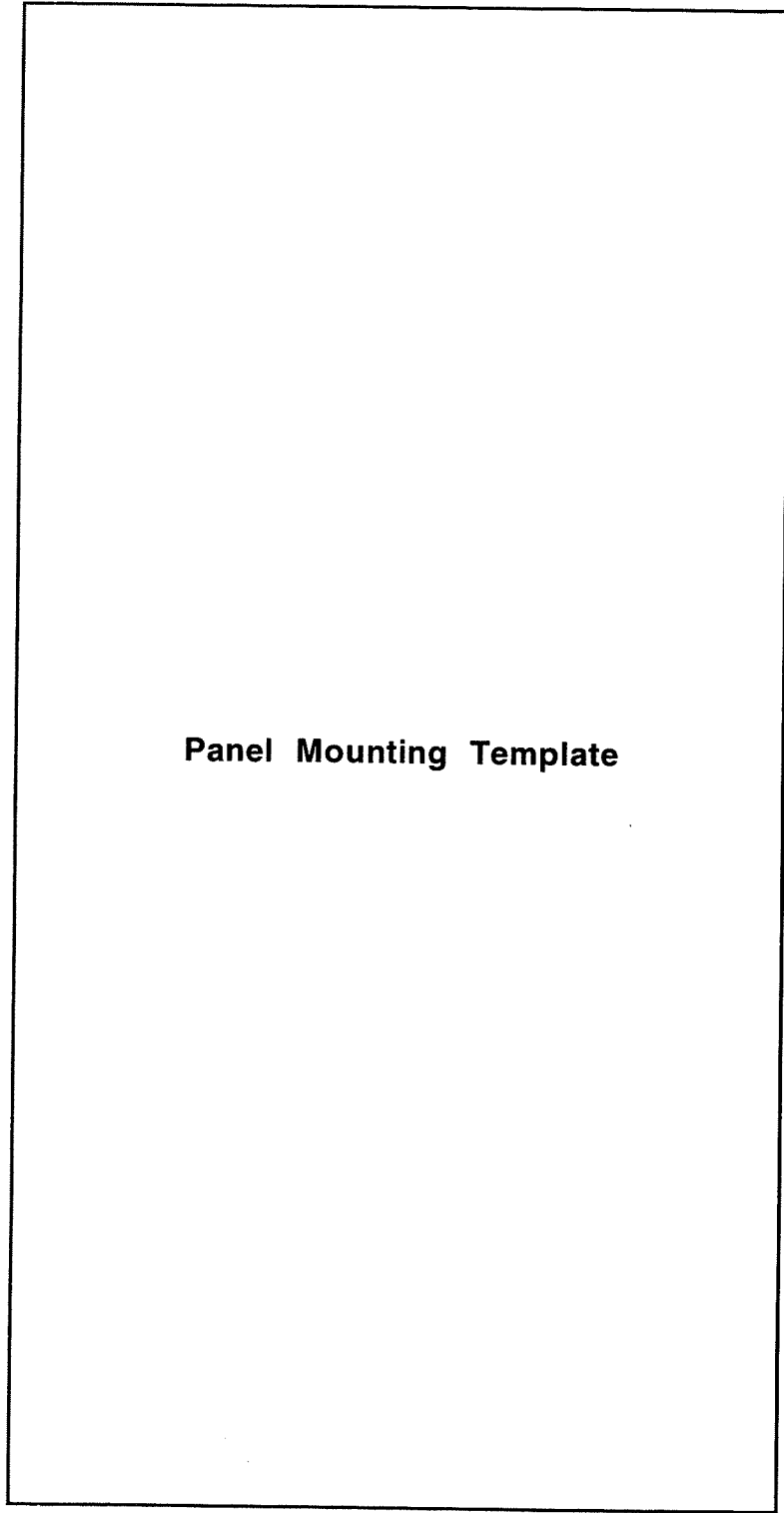

**Panel Mounting Template**

