

Z Series Shunt Regulator

The information in this chapter will enable you to:

- Understand the shunt regulator's purpose
- Install the shunt regulator
- Use this chapter as a quick reference for shunt regulator specifications

What Is A Shunt Regulator?

The Z Shunt Regulator is an option for the Z600, Z800, and Z900 series motor/drives. Two versions of the Z Shunt Regulator are available.

- The ZSR-400W version dissipates 400 watts
- The ZSR-800W version dissipates 800 watts

Helpful Hint:

The Z Shunt Regulator is designed to operate from 0°C - 50°C and dump power at a voltage level of 365VDC

Compumotor recommends that you use this option if your load reflects more energy than the Z Drive can absorb. This typically happens when the drive is decelerating a large inertial load with little or no friction. In this situation, the Z Drive will fault with error code 04 (Drive Overvoltage). The shunt regulator dissipates the reflected energy (heat).

Shunt Regulator Installation

- ① Make sure that power is off before proceeding with this procedure.
- ② Connect V BUS(+) on the Z Drive to V BUS(+) on the shunt regulator.
- ③ Connect V BUS(-) on the Z Drive to V BUS(-) on the shunt regulator.

Helpful Hint:

For best performance, the shunt regulator should be as close to the Z Drive as possible. Use 12 AWG, twisted pair wires (20A - 30A @ 350VDC pulsed) to connect the terminals. The wire should be no longer than 2'.

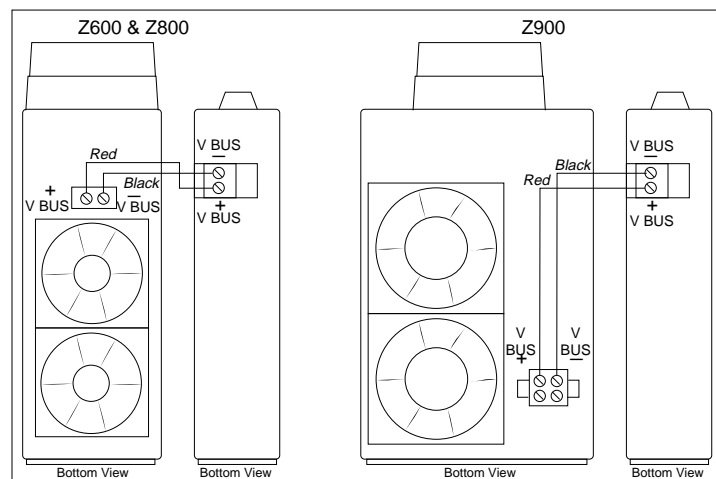

Shunt Regulator Installation

- ④ Mount the shunt regulator so air flows from the bottom to the top of the unit.
- ⑤ Apply power to the Z Drive.

Helpful Hint:

If the shunt regulator is properly configured, the unit's status LED will be illuminated. When the unit is in power dumping, the yellow **REGEN** LED will be illuminated. When power is removed from the Z Drive, the **STATUS** LED will remain on until the bus voltage drops to approximately 60V.

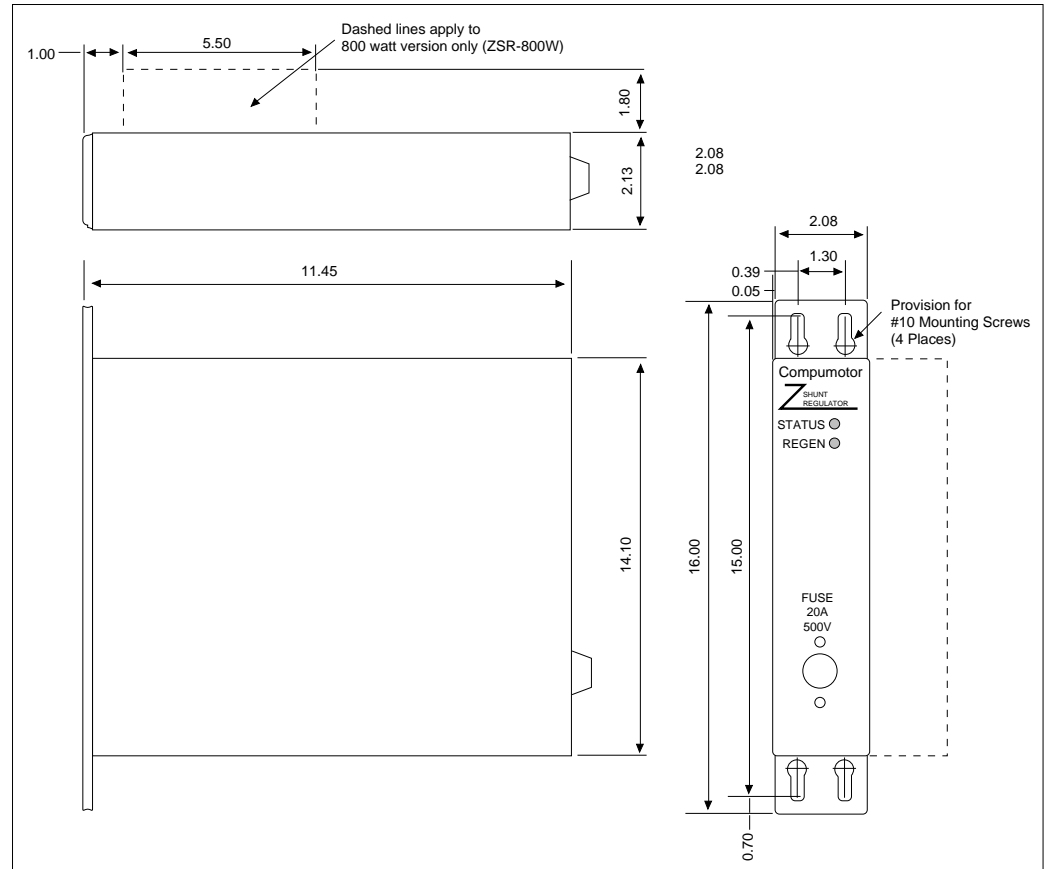

Z Series Shunt Regulator Dimensions

As the motor decelerates the load, the voltage on the DC bus inside the Z Drive increases as the energy is reflected to the drive from the load. The capacitors inside the drive store energy; however, the capacitors' storage capacity is limited. If the energy in the system exceeds the capacitors' storage capacity, the excess energy must be dumped into a shunt regulator. Shunt regulators dump excess energy into resistors. If the bus voltage in the Z Drive rises above 365VDC, **Overvoltage Warning #03** occurs. At a bus voltage of 405VDC the drive faults with an **Overvoltage Fault #04**. A shunt regulator can eliminate these conditions.

Selecting a Z Series Shunt Regulator

To determine which shunt regulator is appropriate for your system, complete the following steps.

- ① Determine how much energy is in the mechanical system. Use the following equation:

Mechenergy (Joules) = $\frac{1}{2} J \omega^2$: Where J is the *system* inertia in Kg-m² and ω is the maximum motor velocity in radians/sec.

- ② Determine if the Z Drive capacitors can absorb the mechanical system's energy. Use the following equation depending on the Z Drive type:

Elecenergy (Joules) = $\frac{1}{2} C V^2$: where C is the capacitance of the Z Drive in Farads. In the Z600s and Z800s, C = 4200 μ F and in the Z900s, C = 8400 μ F. The V that you use to calculate the energy the drive can absorb is the maximum Z Drive voltage

(405VDC) for ELEC/ENERGY1 and the AC line voltage $\cdot \sqrt{2}$ for ELEC/ENERGY2. The absorption capability = ELEC/ENERGY1 — ELEC/ENERGY2

Helpful Hint:
Capacitor Energy
Absorption Calculation

Line voltage is 208VAC applied to a Z620

$$\begin{aligned}\Delta \text{ELEC/ENERGY1} &= \text{ELEC/ENERGY1} - \text{ELEC/ENERGY2} \\ &= \frac{1}{2} C (405)^2 - \frac{1}{2} C (208 \cdot \sqrt{2})^2 \\ &= \frac{1}{2} (0.0042) [405^2 - (208 \cdot \sqrt{2})^2] \\ &= 0.0021 (164,025 - 86,528) \\ &= 162.7 \text{ Joules}\end{aligned}$$

If the amount of mechanical energy in the system is less than the amount of electrical energy that the Z Drive can store, you do not need a shunt regulator. You may run your load at any velocity and decelerate at any rate to a stop without causing an overvoltage fault.

Helpful Hint:
Fast decelerations require more power to be dumped than slow decelerations.

If the system's mechanical energy exceeds the amount that can be absorbed, a shunt regulator may be required. There are several losses in the system that help lower the amount of energy the drive needs to absorb. Friction, drive inefficiencies and I²R losses in the motor are some examples. These losses can skew your ability to determine whether or not a shunt regulator is needed (if your calculations indicate that there is more mechanical energy than electrical energy in the system). If, however, the mechanical energy exceeds the electrical energy that can be absorbed and you want to decelerate the load quickly, you will need a regulator. To select the proper regulator (400W or 800W), additional calculations must be made. Determine the amount of power (not energy) that must be dumped. The power that must be dissipated increases as deceleration time decreases (assuming the same load and peak velocity for the move). Since the average power is the change in energy over time, and the energy in this example is fixed, the only variable is time.

Helpful Hint:
To calculate the time required to decelerate, use the following equation:

$$\text{Time}_{\text{decel}} \text{ (Seconds)} = \frac{(V_{\text{init}} - V_{\text{final}})}{\text{Decel rate}}$$

Where V is in revs/sec and decel rate is in revs/sec²

The shunt regulator for a 240V Z Drive is only active when the bus voltage exceeds 365VDC. The Z Drive absorbs some energy before the shunt becomes active and continues to absorb energy if the bus voltage continues to climb while the regulator is active. Therefore, the amount of electrical energy that the drive can absorb from the mechanical system should be subtracted before calculating the power that must be dumped. For a Z600 or Z800 operating at 240VAC input, subtract 102 joules. For a Z900 at 240VAC, subtract 204 joules. The calculation for a Z600 is shown below:

$$\text{Elec}_{\text{energy}} = \frac{1}{2} (0.0042)[405^2 - (240 \cdot \sqrt{2})^2] = 102 \text{ Joules}$$

Now divide the mechanical energy by the decel time to get the average power in joules that will dissipate over the linear deceleration portion of the move.

$$\text{Power}_{\text{avg}} = \frac{\text{Mech}_{\text{energy}}}{\text{Time}_{\text{decel}}}$$

Helpful Hint:
For moves with a linear deceleration ramp, peak power is twice the average power.

$$\text{Power}_{\text{peak}} = \text{Power}_{\text{avg}} \cdot 2$$

The shunt regulator chosen must be able to dump the **peak** power of the move. If the peak power is too high, lower the deceleration rate or the move velocity. A lower velocity will reduce the stored mechanical energy in the system.

The table below indicates the maximum load-to-rotor inertia ratio for the various motor sizes that you can have without requiring a shunt regulator. These calculations are based on the motors being operated at rated speed and an input power of 240V to the Z Drive. The assumption is that there are no losses in the drive or motor. These numbers are conservative.

Motor	Rated Speed	Load:Rotor Inertia Ratio	Motor	Rated Speed	Load:Rotor Inertia Ratio
605	103.33	3.9:1	640	26.67	2.6:1
606	60.00	7.3:1	910	83.33	0.61:1
610	116.67	0.52:1	920	52.5	0.86:1
620	61.67	1.1:1	930	38.33	1.34:1
630	41.67	2.2:1	940	25.00	0.98:1
635	50.00	1.0:1.0			

As long as the load to rotor inertia ratio is equal to or less than what is in the table, you may run at any velocity and use any deceleration rate ($0 < \text{decel} < \infty$) to stop the load without getting an over voltage **fault** on the drive. If your inertia ratio is greater than the listing, you will have to limit either your deceleration rate or lower the rotor speed. The greater the inertial mismatch, the lower the allowable deceleration rate or velocity.

The table below gives the maximum load-to-rotor-inertia ratio you can use having an infinite deceleration rate without a shunt regulator at various percentages of the rated motor velocity. Again, these numbers are based on 240VAC input power to the Z Drive. Losses are not accounted for, so the numbers are conservative.

Motor	100%	90%	80%	70%	60%	50%	40%	30%	20%	10%
605	3.91	5.06	6.68	9.02	12.64	18.65	29.70	53.58	121.80	490.21
606	7.39	9.36	12.11	16.13	22.31	32.57	51.46	92.25	208.82	838.28
610	0.53	0.89	1.39	2.12	3.24	5.11	8.55	15.98	37.20	151.79
620	1.09	1.59	2.27	3.27	4.82	7.38	12.09	22.27	51.35	208.41
630	2.24	3.00	4.06	5.61	8.00	11.96	19.24	34.99	79.98	322.90
635	1.0	2.48	3.10	4.10	5.60	8.00	12.58	22.4	50.3	201.3
640	2.61	3.46	4.64	6.37	9.03	13.45	21.57	39.13	89.29	360.18
910	0.62	1.00	1.53	2.31	3.50	5.48	9.12	16.99	39.49	160.95
920	0.86	1.30	1.91	2.80	4.18	6.45	10.65	19.71	45.59	185.37
930	1.34	1.89	2.65	3.77	5.50	8.36	13.62	24.99	57.47	232.89
940	0.99	1.46	2.11	3.06	4.53	6.96	11.43	21.10	48.73	197.92

The table is calculating theoretical maximums. It would be difficult, if not impossible, to tune a servo with inertia mismatches greater than 25:1. If your application is not within the ranges in the table, you may need a shunt regulator.

The tables below show the maximum allowable deceleration rates using different wattage shunt regulators at various speeds and with variable inertia ratios. The calculations do not include any losses in the system (the results are conservative).

The load-to-rotor inertia ratios are on the top row of each table. Each table uses a different wattage shunt regulator. These tables can help determine the right shunt regulator for your application (400W or 800W version).

Deceleration rates using a 400W Shunt Regulator
Deceleration rates at 100% of rated speed

Motor	RPS	1:1	2:1	3:1	4:1	5:1	6:1	8:1	10:1	15:1	20:1	25:1
605	103.33	∞	∞	∞	6972.4	862.7	459.8	237.7	160.3	88.4	61.0	46.6
606	60.00	∞	∞	∞	∞	∞	∞	1398.9	362.0	126.9	76.9	55.2
610	116.67	707.5	232.2	138.9	99.1	77.0	63.0	46.2	36.4	23.9	17.7	14.1
620	61.67	∞	269.7	129.9	85.5	63.8	50.8	36.1	28.1	18.0	13.2	10.5
630	41.67	∞	∞	328.8	145.7	93.6	69.0	45.2	33.6	20.5	14.7	11.5
635	50	∞	199.2	99.1	65.9	49.4	39.5	28.2	21.9	14.1	10.38	8.21
640	26.67	∞	∞	437.0	130.9	77.0	54.5	34.4	25.2	15.0	10.7	8.3
910	83.33	328.8	93.6	54.6	38.5	29.8	24.2	17.7	13.9	9.1	6.7	5.4
920	52.50	606.1	82.0	44.0	30.1	22.8	18.4	13.3	10.4	6.7	5.0	3.9
930	38.33	∞	126.7	51.6	32.4	23.6	18.6	13.0	10.0	6.4	4.7	3.7
940	25.00	1487.8	46.7	23.7	15.9	12.0	9.6	6.9	5.3	3.4	2.5	2.0

Deceleration rates at 75% of rated speed

Motor	RPS	1:1	2:1	3:1	4:1	5:1	6:1	8:1	10:1	15:1	20:1	25:1
605	77.50	∞	∞	∞	∞	∞	∞	3624.8	555.7	178.3	106.2	75.6
606	45.00	∞	∞	∞	∞	∞	∞	∞	∞	1049.1	208.7	115.8
610	87.50	∞	1471.8	351.0	199.3	139.1	106.9	73.0	55.5	34.6	25.2	19.8
620	46.25	∞	∞	1051.8	253.5	144.1	100.7	62.8	45.6	27.1	19.3	15.0
630	31.25	∞	∞	∞	∞	1147.3	267.6	105.6	65.8	33.9	22.8	17.2
635	37.5	∞	∞	618.0	184.4	108.4	76.7	48.4	35.4	21.2	15.1	11.7
640	20.00	∞	∞	∞	∞	∞	383.9	94.0	53.6	25.8	17.0	12.7
910	62.50	∞	1147.3	151.5	81.1	55.4	42.0	28.4	21.4	13.3	9.6	7.5
920	39.38	∞	∞	175.0	73.4	46.5	34.0	22.1	16.4	9.9	7.1	5.6
930	28.75	∞	∞	∞	130.7	61.4	40.2	23.7	16.8	9.8	6.9	5.3
940	18.75	∞	∞	128.1	42.8	25.7	18.4	11.7	8.6	5.1	3.7	2.9

Deceleration rates at 50% of rated speed

Motor	RPS	1:1	2:1	3:1	4:1	5:1	6:1	8:1	10:1	15:1	20:1	25:1
605	51.67	∞	∞	∞	∞	∞	∞	∞	∞	∞	1258.3	299.9
606	30.00	∞	∞	∞	∞	∞	∞	∞	∞	∞	∞	∞
610	58.33	∞	∞	∞	∞	∞	724.2	234.0	139.6	69.5	46.2	34.7
620	30.83	∞	∞	∞	∞	∞	∞	701.2	184.5	64.9	39.4	28.3
630	20.83	∞	∞	∞	∞	∞	∞	∞	∞	164.4	64.0	39.7
635	25.0	∞	∞	∞	∞	∞	∞	412.0	133.3	49.5	30.4	21.9
640	13.33	∞	∞	∞	∞	∞	∞	∞	∞	218.5	55.7	31.9
910	41.67	∞	∞	∞	∞	∞	442.0	101.0	57.0	27.3	17.9	13.4
920	26.25	∞	∞	∞	∞	∞	∞	116.7	52.3	22.0	13.9	10.2
930	19.17	∞	∞	∞	∞	∞	∞	∞	99.6	25.8	14.8	10.4
940	12.50	∞	∞	∞	∞	∞	∞	85.4	30.8	11.9	7.3	5.3

Deceleration rates at 25% of rated speed

Motor	RPS	1:1	2:1	3:1	4:1	5:1	6:1	8:1	10:1	15:1	20:1	25:1
605	25.83	∞	∞	∞	∞	∞	∞	∞	∞	∞	∞	∞
606	15.00	∞	∞	∞	∞	∞	∞	∞	∞	∞	∞	∞
610	29.17	∞	∞	∞	∞	∞	∞	∞	∞	∞	∞	760.3
620	15.42	∞	∞	∞	∞	∞	∞	∞	∞	∞	∞	∞
630	10.42	∞	∞	∞	∞	∞	∞	∞	∞	∞	∞	∞
635	12.5	∞	∞	∞	∞	∞	∞	∞	∞	∞	∞	∞
640	6.67	∞	∞	∞	∞	∞	∞	∞	∞	∞	∞	∞
910	20.83	∞	∞	∞	∞	∞	∞	∞	∞	∞	∞	1419.0
920	13.13	∞	∞	∞	∞	∞	∞	∞	∞	∞	∞	∞
930	9.58	∞	∞	∞	∞	∞	∞	∞	∞	∞	∞	∞
940	6.25	∞	∞	∞	∞	∞	∞	∞	∞	∞	∞	∞

Deceleration rates using an 800W Shunt Regulator

Deceleration rates at 100% of rated speed

Motor	RPS	1:1	2:1	3:1	4:1	5:1	6:1	8:1	10:1	15:1	20:1	25:1
605	103.33	∞	∞	∞	∞	1725.3	919.5	475.4	320.6	176.7	122.0	93.1
606	60.00	∞	∞	∞	∞	∞	∞	2797.7	724.0	253.7	153.8	110.4
610	116.67	1414.9	464.5	277.8	198.2	154.0	126.0	92.3	72.9	47.7	35.5	28.2
620	61.67	∞	539.4	259.7	171.0	127.5	101.6	72.3	56.1	36.0	26.5	20.9
630	41.67	∞	∞	657.6	291.5	187.2	137.9	90.3	67.2	40.9	29.4	23.0
635	50.0	∞	398.6	198.2	131.8	98.8	79.0	56.4	43.9	28.2	20.7	16.4
640	26.67	∞	∞	874.1	261.7	153.9	109.0	68.8	50.3	30.1	21.4	16.7
910	83.33	657.6	187.2	109.2	77.0	59.5	48.5	35.4	27.9	18.2	13.5	10.7
920	52.50	1212.1	164.1	88.0	60.1	45.7	36.8	26.5	20.7	13.4	9.9	7.9
930	38.33	∞	253.3	103.1	64.7	47.2	37.1	26.0	20.0	12.7	9.3	7.3
940	25.00	2975.6	93.4	47.5	31.8	23.9	19.2	13.7	10.7	6.9	5.1	4.0

Deceleration rates at 75% of rated speed

Motor	RPS	1:1	2:1	3:1	4:1	5:1	6:1	8:1	10:1	15:1	20:1	25:1
605	77.50	∞	∞	∞	∞	∞	∞	7249.6	1111.4	356.6	212.4	151.2
606	45.00	∞	∞	∞	∞	∞	∞	∞	∞	2098.3	417.3	231.7
610	87.50	∞	2943.5	702.1	398.6	278.3	213.7	146.0	110.9	69.2	50.3	39.5
620	46.25	∞	∞	2103.6	506.9	288.2	201.3	125.6	91.3	54.2	38.6	29.9
630	31.25	∞	∞	∞	∞	2294.5	535.2	211.2	131.6	67.7	45.6	34.4
635	37.5	∞	∞	1236.0	368.8	216.7	153.5	96.9	70.8	42.3	30.1	23.4
640	20.00	∞	∞	∞	∞	∞	767.8	188.1	107.2	51.6	34.0	25.4
910	62.50	∞	2294.5	302.9	162.2	110.7	84.1	56.7	42.8	26.5	19.2	15.1
920	39.38	∞	∞	350.1	146.9	92.9	68.0	44.2	32.8	19.9	14.3	11.1
930	28.75	∞	∞	∞	261.4	122.9	80.3	47.4	33.7	19.5	13.7	10.6
940	18.75	∞	∞	256.1	85.6	51.4	36.7	23.4	17.1	10.3	7.3	5.7

Deceleration rates at 50% of rated speed

Motor	RPS	1:1	2:1	3:1	4:1	5:1	6:1	8:1	10:1	15:1	20:1	25:1
605	51.67	∞	∞	∞	∞	∞	∞	∞	∞	∞	2516.6	599.8
606	30.00	∞	∞	∞	∞	∞	∞	∞	∞	∞	∞	∞
610	58.33	∞	∞	∞	∞	∞	1448.5	468.0	279.1	138.9	92.5	69.3
620	30.83	∞	∞	∞	∞	∞	∞	1402.4	369.1	129.9	78.8	56.6
630	20.83	∞	∞	∞	∞	∞	∞	∞	∞	328.8	127.9	79.4
635	25.0	∞	∞	∞	∞	∞	∞	824.0	266.7	99.1	60.9	43.9
640	13.33	∞	∞	∞	∞	∞	∞	∞	∞	437.0	111.4	63.8
910	41.67	∞	∞	∞	∞	∞	884.0	202.0	114.0	54.6	35.9	26.7
920	26.25	∞	∞	∞	∞	∞	∞	233.4	104.7	44.0	27.9	20.4
930	19.17	∞	∞	∞	∞	∞	∞	∞	199.2	51.6	29.6	20.8
940	12.50	∞	∞	∞	∞	∞	∞	170.8	61.6	23.7	14.7	10.6

Deceleration rates at 25% of rated speed

Motor	RPS	1:1	2:1	3:1	4:1	5:1	6:1	8:1	10:1	15:1	20:1	25:1
605	25.83	∞	∞	∞	∞	∞	∞	∞	∞	∞	∞	∞
606	15.00	∞	∞	∞	∞	∞	∞	∞	∞	∞	∞	∞
610	29.17	∞	∞	∞	∞	∞	∞	∞	∞	∞	∞	1520.6
620	15.42	∞	∞	∞	∞	∞	∞	∞	∞	∞	∞	∞
630	10.42	∞	∞	∞	∞	∞	∞	∞	∞	∞	∞	∞
635	12.5	∞	∞	∞	∞	∞	∞	∞	∞	∞	∞	∞
640	6.67	∞	∞	∞	∞	∞	∞	∞	∞	∞	∞	∞
910	20.83	∞	∞	∞	∞	∞	∞	∞	∞	∞	∞	2837.9
920	13.13	∞	∞	∞	∞	∞	∞	∞	∞	∞	∞	∞
930	9.58	∞	∞	∞	∞	∞	∞	∞	∞	∞	∞	∞
940	6.25	∞	∞	∞	∞	∞	∞	∞	∞	∞	∞	∞