Maintenance & Troubleshooting

The information in this chapter will enable you to:

- Maintain the system's components to ensure smooth, efficient operation
- Isolate and resolve system hardware and software problems
- Quick-reference for system warning & fault codes

Motor Maintenance

The motor should be inspected regularly to ensure that no bolts or couplings have worked loose during normal operation. This could prevent minor problems from developing into major problems.

The motor is brushless and the bearings are sealed. ***No maintenance, other than regular visual inspection, is necessary.***

Drive Maintenance

The Z Drive requires very little maintenance, but the NEMA cabinet should be regularly inspected to make sure that the air filters are kept clean. The Z Drive requires good air flow for proper cooling.

Troubleshooting

If your system malfunctions, you must identify and isolate the problem. The first step is to isolate each system component and ensure that each component functions properly when it is run independently. If you have additional units available, you may want to use them to replace existing components in your system to help identify the source of the problem.

Determine if the problem is mechanical, electrical, or software-related. Can you repeat or re-create the problem? Do not make quick rationalizations about problems. Random events may appear to be related, but they are not necessarily contributing factors to your problem. You must carefully investigate and decipher the events that occurred before the subsequent system problem.

You may be experiencing more than one problem. You must solve one problem at a time. Log (document) all testing and problem isolation procedures. You may need to review and consult these notes later. This will also prevent you from duplicating your testing efforts.

Once you isolate the problem, take the necessary steps to resolve it. Refer to the problem solutions contained in this chapter. If your system's problem persists, contact Compumotor's Applications Engineering Department (800-358-9070).

Diagnostic LEDs

The Z Drive has three diagnostic LEDs on its front panel. Figure 8-1 shows the location of the LEDs.

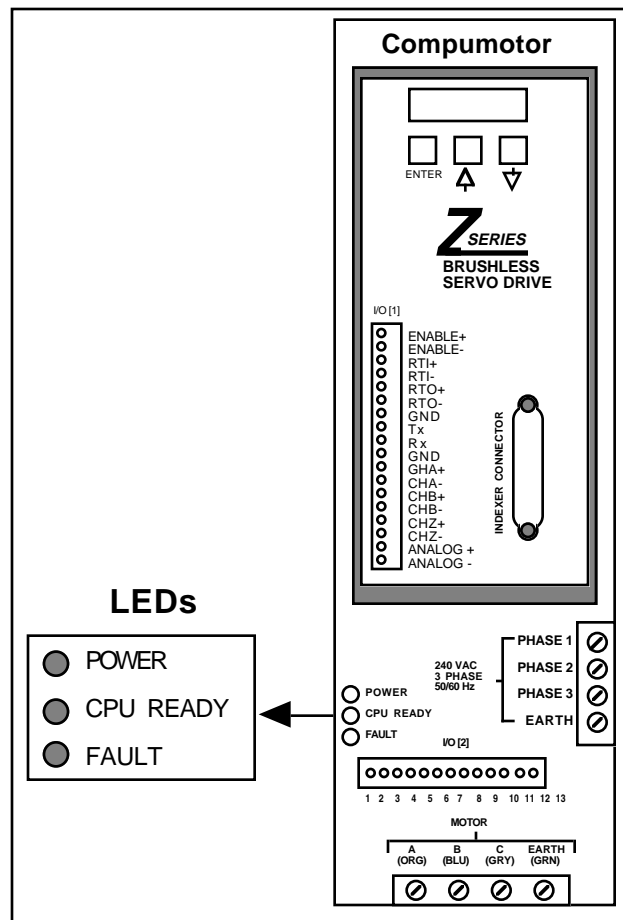

Z Drive LEDs

- POWER** Indicates that the drive is powered-up (normally green).
- CPU READY** Indicates that the processor is properly functioning (normally green).
- FAULT** Indicates a drive fault or error (red when a fault exists; normally off).

In addition to these LED indicators, the Z Drive has a front panel display that scrolls fault messages when a fault occurs. *Chapter 4 Application Design* describes all operations and capabilities of the front panel display.

Drive Warning

The following warning code will be displayed on the alphanumeric display before an overvoltage fault occurs.

Code	Warning	Description
03	OVER VOLTAGE	The internal bus voltage has passed the warning threshold. This warning will not fault the drive; the error threshold (Error 04) will fault the drive. The warning message will remain present until an ON command or a system reset is executed.

Z Drive Warning Code

Drive Faults

The following Fault Codes and messages will be displayed on the alphanumeric display when the respective faults occur. The Report Servo Errors (**RSE**) command also reports faults and warnings.

All of the possible faults are described below, along with some troubleshooting information. Except where noted, the drive can be re-enabled after a fault has occurred by correcting the fault (if applicable) and typing a **ON** command.

Code	Fault	Description
04	OVER VOLTAGE	The internal bus voltage has exceeded its limit. Verify the input power voltage. This error may also be caused by rapid decelerations. You may need to use the Shunt Regulator option to dissipate the stored mechanical energy as heat. This error overrides the over voltage warning.
17	INDEXER SHUTDOWN	The Remote Power Shutdown input on the indexer connector has been activated, causing the drive to shutdown. Removing this input will re-enable the drive.
18	LOW VOLTAGE	The input power to the drive is either not present, or at a lower voltage than 92V. Verify the input power voltage and make sure that the power is correctly connected.
19	OVER-CURRENT (SHORT CIRCUIT)	A short circuit between motor phases, or between any phase and ground will cause the drive to fault. This may be due to improper motor wiring to the drive or due to a bad motor. In some cases an extremely high acceleration may cause this error. Power down the complete Z Drive, correct the wiring, and power-up the system. This fault cannot be removed by typing the ON command.
20	POSITION ERROR EXCEEDED	The user defined position error limit has been exceeded. The CPE (Configure Position Error) command can alter the error limit. The factory default is one revolution (5,000 motor steps). A position error may be caused by a rapid acceleration rate or possibly bad servo tuning. The user must decide whether to increase the position error limit or to change his motion profile so that the drive no longer faults out.
21	ROLLING AVERAGE CURRENT FAULT	The user specified average current limit has been exceeded. The CCA (Configure Current Average) command alters the average current limit. If the drive continues to fault out, you may have to reduce the acceleration rate of your move. The average current of the drive is calculated over a rolling 4-second time period.
22	AVERAGE CURRENT LIMIT EXCEEDED	The drive's average current limit has been exceeded. A hardware detect circuit has turned the drive off due to too much current.
23	DRIVE ENABLE INPUT NOT ACTIVE	The drive enable input on the screw terminal connector I/O[1] has been deactivated. For drive operation, a normally closed switch or wire jumper is necessary from ENABLE+ to ENABLE-input. The Z Drive is shipped with a jumper installed.
27	VELOCITY ERROR EXCEEDED	The user-defined velocity error limit has been exceeded. The CVE (Configure Velocity Error) command can alter the error limit. A velocity error may be caused by a rapid acceleration rate or bad servo tuning.
30	Z RAM FAILURE	This error should occur only during factory initialization of the Z Drive.
55	POWER SUPPLY FAILURE	This error indicates that the isolated power supply for the Z Drive's amplifier has failed. Call Compumotor (800-358-9070).
60	COMMANDED SHUTDOWN	The Z Drive has been commanded off by the OFF command.
61	INCOMING INDEXER PULSES	When the Z Drive is reset or commanded ON , no step pulses are accepted when the amplifier is first enabled (this would constitute infinite acceleration). Make sure that the indexer connected to the Z Drive is not sending out any pulses before commanding the drive ON .
62	CURRENT INTEGRATION FAULT	Currently this fault is not enabled.
70	RESOLVER DISCONNECTED	The resolver feedback signal from the motor to the drive is missing. This feedback is required to operate the drive. Make sure the resolver connection is secure.
77	RESOLVER RESOLUTION FAULT	For a given resolver resolution there is a maximum velocity at which the resolver-digital converter can operate. If the drive faults due to this error, the maximum velocity commanded to the drive exceeds the capabilities of the resolver-digital converter. See the CRR command.
91	HEATSINK OVER TEMPERATURE	The internal heatsink of the Z Drive has reached its temperature limit. Make sure the ambient temperature for the drive is within specifications.
92	MOTOR OVER TEMPERATURE	The motor has reached its temperature limit. Make sure the ambient temperature for the motor is within specifications. Also make sure the drive is configured correctly for the motor you are using. See the CMTR command.
93	PCB OVER TEMPERATURE	The Printed Circuit Board temperature limit has been reached. Make sure the ambient temperature for the drive is within specifications.

Drive Fault Codes

RS-232C Problems

Use the following procedure to resolve Z Drive communication problems.

- ① Be sure the host computer's transmit (Tx) wire is wired to the peripheral's receive (Rx) connection, and the host computer's receive (Rx) wire is wired to the peripheral's transmit (Tx) connection. Switch the receive and transmit wires on either the host or peripheral if the problem persists.
- ② Confirm that the host and peripheral are configured for the same baud rate, 8 data bits, 1 stop bit, and no parity.
- ③ If you receive double characters, for instance typing A and receiving AA, the computer is set for half duplex mode. Change the setup to Full Duplex mode.
- ④ Use DC common or signal ground as a reference, not earth ground.
- ⑤ Cable lengths should not exceed 50 ft. unless you are using some form of line driver, optical coupler, or shield. As with any control signal, be sure to shield the cable-to-earth ground at one end only.
- ⑥ To test the terminal or terminal emulation software and the RS-232C cable for proper three-wire communication, unhook the Z Drive and enter a character. You should not receive an echoed character. If you do, you are in half duplex mode. Connect the host's transmit and receive lines together and send another character. You should receive the echoed character. If not, consult the manufacturer of the host's serial interface for proper pin outs.

Returning The System

If your Z Drive system is faulty, you must return the drive and motor for replacement or repair. A failed drive can damage motors, and a faulty motor can damage subsequent drives. If you must return your Z Drive to effect repairs or upgrades, use the following steps:

- Step ① Get the serial number and the model number of the defective unit(s), and a purchase order number to cover repair costs in the event the unit is determined by Parker Compumotor to be out of warranty.
- Step ② Before you ship the drive to Parker Compumotor, have someone from your organization with a technical understanding of the Z Drive and its application include answers to the following questions:
- What is the extent of the failure/reason for return?
 - How long did it operate?
 - How many units are still working?
 - How many units failed?
 - What was happening when the unit failed (i.e., installing the unit, cycling power, starting other equipment, etc)?
 - How was the product configured (in detail)?
 - What, if any, cables were modified and how?
 - With what equipment is the unit interfaced?
 - What was the application?
 - What was the system sizing (speed, acceleration, duty cycle, inertia, torque, friction, etc.)?
 - What was the system environment (temperature, enclosure, spacing, unit orientation, contaminants, etc.)?
 - What upgrades, if any, are required (hardware, software, user guide)?
- Step ③ Call Parker Compumotor [(800) 358-9070] for a Return Material Authorization (RMA) number. Returned products cannot be accepted without an RMA number.
- Step ④ Ship the unit to:
- Parker Compumotor Corporation
5500 Business Park Drive
Suite D
Rohnert Park, CA 94928
Attn: RMA # xxxxxxxx

A P P E N D I X

Alphabetical Command List

ANDB	Analog Voltage Deadband	RFS	Return to Factory Settings
ANV	Analog Voltage Range	RSE	Report Servo Errors
ANZ	Analog Voltage Zero	RV	Revision Level
CCA	Configure Current Average	SS	Set-Up Status Report
CCP	Configure Current Peak	SSA	RS-232C Echo Control
CDB	Configure Deadband	SSI	Interactive Mode Control
CIP	Configure In-Position	SSM	Direction Input Polarity Control
CMR	Configure Motor Resolution	SSR	Analog Output Control
CMTR	Configure Motor Type	SST	Enable Input Control
CMV	Configure Maximum Velocity	SSU	Set Warning Display Mode
CPB	Configure Pushbuttons	SV	Save
CPD	Configure Position Derivative	Z	Reset
CPDM	Configure Position Derivative Maximum		
CPE	Configure Position Error		
CPI	Configure Position Integral		
CPIM	Configure Position Integral Maximum		
CPP	Configure Position Proportional		
CPPM	Configure Position Proportional Maximum		
CRR	Configure Resolver Resolution		
CTC	Configure Time Constant		
CTG	Configure Tach Gain		
CTGM	Configure Tach Gain Maximum		
CVD	Configure Velocity Derivative		
CVDM	Configure Velocity Derivative Maximum		
CVE	Configure Velocity Error		
CVF	Configure Velocity Feed-Forward		
CVFM	Configure Velocity Feed-Forward Maximum		
CVI	Configure Velocity Integral		
CVIM	Configure Velocity Integral Maximum		
CVP	Configure Velocity Proportional		
CVPM	Configure Velocity Proportional Maximum		
CZM	Configure Z Drive Mode		
DCA	Display Current Average		
DCI	Display Current Instantaneous		
DCP	Display Current Peak		
DDI	Display Drive Information		
DISP	Front Panel Display		
DPA	Display Position Actual		
DPE	Display Position Error		
DPR	Display Position Resolver		
DPS	Display Position Setpoint		
DSP	Display Servo Picture		
DVA	Display Velocity Actual		
DVE	Display Velocity Error		
DVS	Display Velocity Setpoint		
E	Enable Communications Interface		
F	Disable Communications Interface		
FMCA	Find Motor Commutation Angle		
^H	Backspace		
HELP	Help		
OFF	Amplifier Off		
ON	Amplifier On		
OUT	Real Time Output Control		

I N D E X

A

ACCURACY 106
ALPHANUMERIC DISPLAY 47
ANALOG CONTROL LOOP 43
ANG GRAPHICAL RELATIONSHIP 65

B

BENCH TEST 6, 11, 12, 13
Z600/Z800 6
Z900 6

C

COMMAND 76, 77
COMMANDS
ANALOG OUTPUT CONTROL 82
ANALOG VOLTAGE DEADBAND 65
ANALOG VOLTAGE GAIN 65
ANALOG VOLTAGE RANGE 65
ANALOG VOLTAGE ZERO 66
ANALOG ZERO 13
BACKSPACE 78
CHARACTERISTICS 62
CONFIGURE CURRENT AVERAGE 66
CONFIGURE CURRENT PEAK 66
CONFIGURE DEADBAND 66
CONFIGURE IN-POSITION 67
CONFIGURE MAXIMUM VELOCITY 68
CONFIGURE MOTOR 67
CONFIGURE MOTOR RESOLUTION 67
CONFIGURE POSITION DERIVATIVE 68
CONFIGURE POSITION DERIVATIVE
MAXIMUM 68
CONFIGURE POSITION ERROR 69
CONFIGURE POSITION INTEGRAL 69
CONFIGURE POSITION INTEGRAL
MAXIMUM 69
CONFIGURE POSITION PROPORTIONAL 69
CONFIGURE POSITION PROPORTIONAL
MAXIMUM 70
CONFIGURE PUSHBUTTONS 68
CONFIGURE RESOLVER RESOLUTION 70
CONFIGURE TACH GAIN 71
CONFIGURE TACH GAIN MAXIMUM 71
CONFIGURE TIME CONSTANT 70
CONFIGURE VELOCITY ERROR 71
CONFIGURE VELOCITY FEED-FORWARD
71
CONFIGURE VELOCITY FEED-FORWARD
MAXIMUM 72
CONFIGURE VELOCITY INTEGRAL 72
CONFIGURE VELOCITY INTEGRAL
MAXIMUM 72
CONFIGURE VELOCITY PROPORTIONAL
72
CONFIGURE VELOCITY PROPORTIONAL
MAXIMUM 73
CONFIGURE Z DRIVE MODE 73
DEFAULT 62
DESCRIPTION 63
DIRECTION INPUT POLARITY CONTROL 82
DISABLE COMMUNICATIONS INTERFACE
77
DISPLAY CURRENT AVERAGE 73
DISPLAY CURRENT INSTANTANEOUS 74
DISPLAY CURRENT PEAK 74
DISPLAY DRIVE INFORMATION 11, 14, 74
DISPLAY POSITION ACTUAL 75
DISPLAY POSITION ERROR 75
DISPLAY POSITION RESOLVER 76
DISPLAY SERVO PICTURE 76
DISPLAY VELOCITY ACTUAL 76

DISPLAY VELOCITY SETPOINT 77
ENABLE COMMUNICATIONS INTERFACE
77
ENABLE INPUT CONTROL 82
FIND MOTOR COMMUTATION ANGLE 78
FRONT PANEL DISPLAY 75
HELP 78
INTERACTIVE MODE CONTROL 81
OFF 78
ON 79
REAL TIME OUTPUT CONTROL 79
REPORT SERVO ERRORS 80
RESET 83
RETURN TO FACTORY SETTINGS 79
REVISION LEVEL 80
RS-232C ECHO CONTROL 81
SAVE TUNING PARAMETERS 83
SET WARNING DISPLAY MODE 82
SET-UP STATUS REPORT 81

CONNECTIONS

INDEXER CONNECTOR PIN-OUT 31
RESOLVER PIN-OUT 31
RS-232C 36
Z600/800 MOTOR CABLE CONNECTION 8
Z600/800 POWER CABLE 9
Z600/800 RESOLVER CABLE 7
Z900 MOTOR CABLE CONNECTION 8
Z900 POWER CABLE 9
Z900 RESOLVER CABLE 7
ZX600/800 POWER 40
ZX900 POWER 40

CONNECTORS

MOTOR 29
RESOLVER 29
CONTROL LOOPS 43
COOLING
AIR FLOW AND PANEL LAYOUT
GUIDELINES 17
COUPLERS 28

D

DIGITAL CONTROL LOOP 43
DIMENSIONS
Z600/800 DRIVE 16
Z900 DRIVE 16
DISPLAY AND PUSHBUTTONS 47
DRIVE FAULT CODES 115
DRIVE MOUNTING 15
DRIVE/MOTOR CONFIGURATION 5
120VAC VERSION 6
240VAC VERSION 6

E

ENCODER
CHANNEL A 53
CHANNEL B 53
CHANNEL Z 53
PSEUDO-QUADRATURE OUTPUTS 53
ENVIRONMENTAL
OPERATING TEMP. 15
STORAGE TEMP. 15
ENVIRONMENTAL CONSIDERATIONS 15
ERROR CODES , SEE FAULT CODES

F

FAULT
MESSAGE 47
FAULT CODES 80, 115

I

I/O [1] CONNECTOR

ANALOG INPUT 37
CHA, CHB, AND CHZ OUTPUTS 38
ENABLE INPUT 37
RS-232C 36
RTI INPUT 37
RTO OUTPUT 38
SCREW TERMINAL 35
I/O [2] CONNECTOR
ANALOG MONITOR OUTPUT 39
DRIVE FAULT RELAY OUTPUT 39
I/O[2] CONNECTOR ALSO HAS TWO
OUTPUTS. 39
INDEXER CONNECTOR
DIRECTION INPUT 33
DRIVE FAULT OUTPUT 34
FAULT RESET 34
IN-POSITION OUTPUT 35
REMOTE POWER SHUTDOWN 33
STEP INPUT 32
INTERFACE OPTIONS 2

L

LEDS 114
CPU READY 114
FAULT 114
POWER 114

M

MAIN MENU 47
MAINTENANCE 113
MODES OF OPERATION
POSITION MODE 2, 10
TORQUE MODE 2, 12
VELOCITY MODE 2, 13
MOTOR BRAKING 30
WIRING 30
MOTOR DIMENSIONS
Z605—Z610 18
Z620 & Z630 19
Z635 & Z640 20
Z800 MOTOR SHAFT DIMENSIONS 24
Z805 & 806 21
Z810 22
Z820, 830, & 840 23
Z910 25
Z920 & Z930 26
Z940 27
MOTOR MAINTENANCE 113
MOTOR SPECIFICATIONS
Z605 87
Z606 88
Z610 89
Z620 90
Z630 91
Z635 92
Z640 93
Z806 98
Z810 99
Z820 100
Z830 101
Z840 102
Z910 107
Z920 108
Z930 109
Z940 110
MOUNTING
MOTORS 17
PANEL LAYOUT 17
SCREWS 16

N

NEMA 15

P

POWER 40
POWER LED 13
PRODUCT LABELS 6
PUSHBUTTONS 47
 CMTR MENU 49
 DISP MENU 48
 MISC MENU 49
 TUNE MENU 48

R

REPAIR 116
RESOLVER CABLE 7
RESOLVER MECHANICAL DRAWING 4
RETURN MATERIAL AUTHORIZATION (RMA) 116
RS-232C 10
 BAUD RATE 10
 DAISY CHAIN 36
 DATA BITS 10
 ENABLE INPUT 10
 FULL DUPLEX MODE 10, 11
 HALF DUPLEX MODE 11
 PARITY 10
 PROBLEMS 116
 STOP BITS 10

S

SCHEMATIC
 ANALOG VELOCITY INPUT 37
 DIRECTION INPUT 33
 DRIVE FAULT 34
 ENABLE INPUT 37
 FAULT RESET INPUT 34
 IN-POSITION OUTPUT 35
 PSEUDO-QUADRATURE 38
 REAL-TIME INPUT 37
 REAL-TIME OUTPUT 38
 REMOTE POWER SHUTDOWN 33
 RS-232C INPUT 36
 STEP INPUT 32
SHIP KIT 5
SHUNT REGULATOR 55
 DIMENSIONS 56
 DRIVE OVERVOLTAGE 55
 MECHANICAL ENERGY 57
 SHUNT REGULATOR INSTALLATION 55
SYSTEM WIRING 29

T

TEMPERATURE SENSORS 17
TORQUE MODE TUNING 51
 ANALOG DEADBAND (ANDB) 51
 ANALOG VOLTAGE RANGE (ANV) 51
 ANALOG ZERO (ANZ) 51
TROUBLESHOOTING 113
TUNING 46
 COMMANDS 46, 64
 PARAMETERS 44
 POSITION MODE 50
 RS-232C INTERFACE 44
 TORQUE MODE 50, 51
 VELOCITY MODE 51
TUNING PARAMETER COMMANDS 44
TUNING PROCEDURE
 POSITION MODE. 50
 VELOCITY MODE. 52

V

VELOCITY MODE TUNING
 ANALOG DEADBAND (ANDB) 51
 ANALOG VOLTAGE RANGE (ANV) 51
 ANALOG ZERO (ANZ) 51

W

WARNING CODE 114

Z

Z600
 ELECTRICAL SPECIFICATIONS 85
 MOTOR BRAKE CHARACTERISTICS 86
 MOTOR/DRIVE CONFIGURATION 86
 PERFORMANCE SPECIFICATIONS 86
 REPEATABILITY 86
 RESOLVER ACCURACY 86
 RESOLVER-TO-DIGITAL CONVERTER ACCURACY 86
 SPEED/TORQUE CURVES 94
 Z605 MOTOR SPECIFICATIONS 87
 Z606 MOTOR SPECIFICATIONS 88
 Z610 MOTOR SPECIFICATIONS 89
 Z620 MOTOR SPECIFICATIONS 90
 Z630 MOTOR SPECIFICATIONS 91
 Z635 MOTOR SPECIFICATIONS 92
 Z640 MOTOR SPECIFICATIONS 93

Z800
 ELECTRICAL SPECIFICATIONS 95
 MOTOR BRAKE CHARACTERISTICS 96
 PERFORMANCE SPECIFICATIONS 95
 REPEATABILITY 96
 RESOLVER ACCURACY 96
 RESOLVER-TO-DIGITAL CONVERTER ACCURACY 96
 SPEED/TORQUE CURVES 103
 Z805 MOTOR SPECIFICATIONS 97
 Z806 MOTOR SPECIFICATIONS 98
 Z810 MOTOR SPECIFICATIONS 99
 Z820 MOTOR SPECIFICATIONS 100
 Z830 MOTOR SPECIFICATIONS 101
 Z840 MOTOR SPECIFICATIONS 102

Z900
 ELECTRICAL SPECIFICATIONS 105
 INPUT POWER 105
 PERFORMANCE SPECIFICATIONS 105
 REPEATABILITY 106
 RESOLVER ACCURACY 106
 RESOLVER-TO-DIGITAL CONVERTER ACCURACY 106
 SPEED/TORQUE CURVES 111
 MOTOR BRAKE CHARACTERISTICS 106
 Z910 MOTOR SPECIFICATIONS 107
 Z920 MOTOR SPECIFICATIONS 108
 Z930 MOTOR SPECIFICATIONS 109
 Z940 MOTOR SPECIFICATIONS 110