

USER GUIDE CHANGE SUMMARY

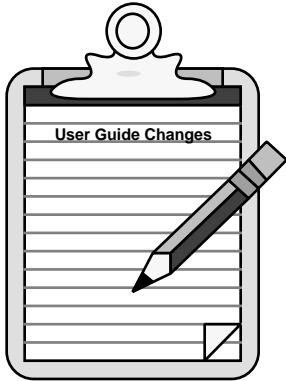

The following is a summary of the primary changes to this user guide since the last version was released. This user guide, version **88-010759-01H**, supersedes version 88-010759-01G.

The entire user guide has been changed according to the new Compumotor user guide styles, format, and illustration standards. Also, the chapters have been renumbered and reorganized. Technical changes to each chapter are summarized below.

Chapter ①
Introduction

The Z635 motor was added to the “*What You Should Have*” section.

Chapter ②
Getting Started

Chapter ② was unchanged.

Chapter ③
Installation

- Installation (wiring) directions were provided for the Brake (-B) Braking option.
- Maximum step rate was corrected (was 2.5 MHz, changed to 1 MHz). See STEP Input.
- The DIRECTION Input schematic was modified.

Chapter ④
Application
Design

Chapter ④ was unchanged.

Chapter ⑤
Z Series Shunt
Regulator

The capacitor energy absorption calculation was modified (refer to “*Selecting a Z Series Shunt Regulator.*”)

Chapter ⑥
Software
Reference

In the CTC command description, time increments were corrected from **ms** to **μs**.

Chapter ⑦
Hardware
Reference

An exception for Z600 and Z900 Series motors was added regarding the IP Classification. The shaft is IP30 rated (not IP65).

Chapter ⑧
Maintenance &
Troubleshooting

Chapter ⑧ was unchanged.

T A B L E O F C O N T E N T S

How To Use This User Guide.....	iii
Assumptions.....	iii
Installation Process Overview.....	iii
Installation Procedures.....	iii
Contents of This User Guide.....	iii
Related Publications.....	iv
① INTRODUCTION	1
Product Description.....	1
Product Features.....	2
Interface Options.....	2
Theory of Operation.....	2
② GETTING STARTED	5
What You Should Have.....	5
Drive/Motor Configuration.....	5
Check-Out Procedure.....	6
Tools.....	6
Position Mode.....	11
Torque Mode.....	12
Velocity Mode.....	13
③ INSTALLATION.....	15
Environmental Considerations.....	15
Complete System Configurations.....	15
Drive Mounting.....	15
Panel Layout.....	17
Motor Mounting.....	17
System Wiring.....	29
Connections.....	29
Resolver Connections.....	31
Indexer Connections.....	31
Indexer Connector Outputs.....	34
I/O[1] Connections.....	35
I/O[2] Connections.....	39
Line Power Connections.....	39
Check-Out Procedure.....	41
④ APPLICATION DESIGN.....	43
Basic Servo Tuning Theory.....	43
Servo Tuning.....	46
Alphanumeric Display and Pushbuttons.....	47
Tuning in Different Modes of Operation.....	49
Position Mode.....	50
Torque Mode.....	50
Velocity Mode.....	51
Pseudo-Quadrature Outputs.....	53
⑤ Z SERIES SHUNT REGULATOR.....	55
What Is A Shunt Regulator?.....	55
Shunt Regulator Installation.....	55
Selecting a Z Series Shunt Regulator.....	56

⑥ SOFTWARE REFERENCE	61
Command Format Description	61
① Command Identifier	61
② Command name	61
③ Version	62
④ Characteristics	62
⑤ Attributes	63
⑥ Description	63
⑦ Example	63
Command List	64
Alphabetical Command List	65
⑦ HARDWARE REFERENCE	85
Z600 Electrical Specifications	85
Input Power	85
Output Power	85
Z600 Motor/Drive Configuration	85
Z600 Technical Data	86
Positional Repeatability	86
Positional Accuracy	86
Motor/Drive Compatibility	86
Motor Brakes	86
Motor Data	86
Speed/Torque Curves	94
Z800 Electrical Specifications	96
Input Power	96
Output Power	96
Z800 Motor/Drive Configuration	96
Z800 Technical Data	96
Positional Repeatability	97
Positional Accuracy	97
Motor/Drive Compatibility	97
Motor Brakes	97
Motor Data	97
Speed/Torque Curves	104
Z900 Electrical Specifications	106
Input Power	106
Output Power	106
Z900 Motor/Drive Configuration	106
Z900 Technical Data	106
Positional Repeatability	107
Positional Accuracy	107
Motor Drive Compatibility	107
Motor Brakes	107
Motor Data	107
Speed/Torque Curves	112
⑧ MAINTENANCE & TROUBLESHOOTING	113
Motor Maintenance	113
Drive Maintenance	113
Troubleshooting	113
Diagnostic LEDs	114
Drive Warning	114
Drive Faults	115
RS-232C Problems	116
Returning The System	116
APPENDIX	117
Alphabetical Command List	117
INDEX	119

How To Use This User Guide

This user guide is designed to help you install, develop, and maintain your system. Each chapter begins with a list of specific objectives that should be met after you have read the chapter. This section should help you find and use the information in this user guide.

Assumptions

This user guide assumes that the user has a fundamental understanding of the following information.

- ❑ Basic electronic concepts (voltages, switches, current, etc.)
- ❑ Basic motion control concepts (torque, velocity, distance, force, etc.)

Installation Process Overview

To ensure trouble-free operation, you should pay special attention to the environment in which the Z Drive equipment will operate. Environmental conditions include the layout, mounting, and wiring and grounding practices used. These recommendations are intended to help you easily and safely integrate the Z Drive into your facility.

Installation Procedures

Before you attempt to install this product, you should complete the following steps:

- ① Review this user guide. Become familiar with the user guide's contents so that you can quickly find the information you need.
- ② Develop a basic understanding of all system components, their functions, and interrelationships.
- ③ After you have read Chapter ③ and clearly understand what must be done to properly install the system, begin the installation process. Do not deviate from the sequence or installation methods provided.
- ④ Before you customize your system, check all of the system functions and features to ensure that you have completed the installation process correctly.

The successful completion of these steps will prevent subsequent performance problems and allow you to isolate and resolve any potential system difficulties before they affect your system.

Contents of This User Guide

This user guide contains the following information.

Chapter ①: Introduction	This chapter provides a description of the product and a brief account of its features.
Chapter ②: Getting Started	This chapter contains a detailed list of items you should have received with your Z Drive shipment. It will help you become familiar with the system and ensure that each component functions properly.
Chapter ③: Installation	This chapter provided instructions for you to properly mount the system and make all electrical and non-electrical connections. Upon completion of this chapter, your system should be completely installed and ready to perform basic operations.
Chapter ④: Application Design	This chapter provides additional information that will help you customize the system to meet your application's needs. Important application considerations are discussed. Sample applications are provided.
Chapter ⑤: Software Reference	This chapter describes the Z Drive's set-up commands. These commands allow you to set system parameters, tune the drive, and display drive status.
Chapter ⑥: Z Series Shunt Regulator	This chapter contains information on the shunt regulator option for the Z Drive. Installation instructions, dimensions, and selection criteria (400W version vs. 800W version) are included.

- Chapter ⑦: This chapter contains information on system specifications (dimensions and performance). This chapter may be used as a quick-reference tool for proper I/O connections.
Hardware Reference
- Chapter ⑧: This chapter describes Compumotor's recommended system maintenance procedures. It also provides methods for isolating and resolving hardware and software problems. Diagnostic error codes are listed.
Maintenance & Troubleshooting

Related Publications

The following publications may be helpful resources.

Seyer, Martin. *RS-232C Made Easy: Connecting Computers, Printers, Terminals and Modems*. Englewood Cliffs, New Jersey: Prentice Hall, Inc., 1984

Current Parker Compumotor Motion Control Catalog

Manual for the IBM or IBM-compatible computer that you may use with the Z Drive

Schram, Peter (editor). *The National Electric Code Handbook (Third Edition)*. Quincy, MA: National Fire Protection Association

Introduction

The information in this chapter will enable you to:

- ❑ Understand the product's basic functions, features, and theory of operation

Product Description

The Z Drive is a brushless servo system that includes a brushless servomotor, a brushless resolver (for feedback), and a Digital Signal Processor (DSP) based servo amplifier. Digital electronics simplify system operation and maintenance.

The Z Drive can accept either a digital (Step and Direction) input or an analog ($\pm 10V$) input. You can configure the Z Drive to servo on commanded position, velocity, or torque. The series offers maximum speeds of 7000 rpm, maximum continuous torques of 9000 oz-in, and maximum peak torques of 18000 oz-in.

The Z Drive uses two processors to achieve high-performance servo control. The first processor (DSP) compares the commanded inputs (position, velocity, or torque) to the resolver feedback, and then determines the proper motor currents to apply. The second processor handles all user communication, error checking, and additional I/O. All servo performance parameters are stored in battery-backed RAM (random access memory).

Z Drive systems can be installed and operated easily with minimal training in servo systems. Z Series motor/drives are supplied as packaged systems that are factory compensated for typical load and performance requirements. In most applications, no adjustments will be required. When adjustments are required, changes to the drive can be made from two interfaces—push-button adjustments or an RS-232C interface. These interfaces provide access to all servo parameters simply and effectively.

The Z Drive's power amplifier uses a bipolar 7 kHz pulse-width modulation (PWM) sinusoidal current control scheme. This type of amplifier improves reliability, power regulation, and low-speed smoothness.

Product Features

- Brushless servo motor
- Brushless resolver feedback
- Speeds to 7000 rpm
- Torques to 9000 oz-in continuous (18000 oz-in peak)
- User programmable resolutions (200 - 65536 steps/rev, 5000 steps/rev standard)
- Multi-processor control: no drift, no analog pots to adjust
- Fan-cooled compact drive enclosure
- 7 kHz PWM switching frequency
- Accepts digital step and direction inputs
- Accepts analog ($\pm 10V$) input for velocity or torque control
- Analog ($\pm 10V$) output monitor for either velocity or torque
- Pseudo 4096 pulse per revolution (ppr) incremental encoder output for interfacing with servo controls
- Servo parameters factory-set and stored in battery-backed RAM (random access memory)
- High-noise immunity due to optical isolation and brushless resolver technology
- Simple push-button adjustment of servo gains
- Alphanumeric display for fault or user-defined messages
- RS-232C interface

Interface Options

In Step and Direction mode, the Z Drive is compatible with all Compumotor indexers. The Z Drive moves the motor one increment in the specified direction for each step pulse received. Both of the drive's Step and Direction inputs are optically isolated and can be driven by an external pulse generator. The Z Drive's resolution is programmable, so you can specify convenient motor increments. The optically isolated analog input accepts a $\pm 10V$ signal that may be configured as either a velocity or torque command.

The ZX is the drive/indexer version of the Z Drive. It contains the servo controller and a complete RS-232C based indexer that executes Compumotor's X Series programming language. You can combine motion control parameters such as distance, velocity, and acceleration into sequences with time delays, loops, and programmable outputs. These sequences can be controlled via RS-232C or via external inputs that can be connected to a PLC or host computer. You can use trigger inputs to coordinate program execution with external events. Multiple motion control programs can be stored in nonvolatile memory and executed automatically from external sequence and trigger controls. The X Series language is based on simple commands, and uses decimal numbers.

Theory of Operation

The Z Drive's primary function is to servo to either a digital position command from an indexer or to an analog voltage command (velocity or torque) from a servo controller.

In **Position mode**, the indexer sends a position command to the drive and the resolver feeds back the actual position of the shaft. If the actual position of the shaft is different from the commanded position, a positional error is produced. The drive then commands torque to the motor to correct the positional error. In **Velocity mode**, the servo controller sends a velocity command and the drive servos to it by comparing the commanded velocity to the actual velocity. In **Torque mode**, the servo controller controls the actual shaft torque directly.

The Z Drive digital servo system is composed of three major components: the servo motor, the drive, and the resolver.

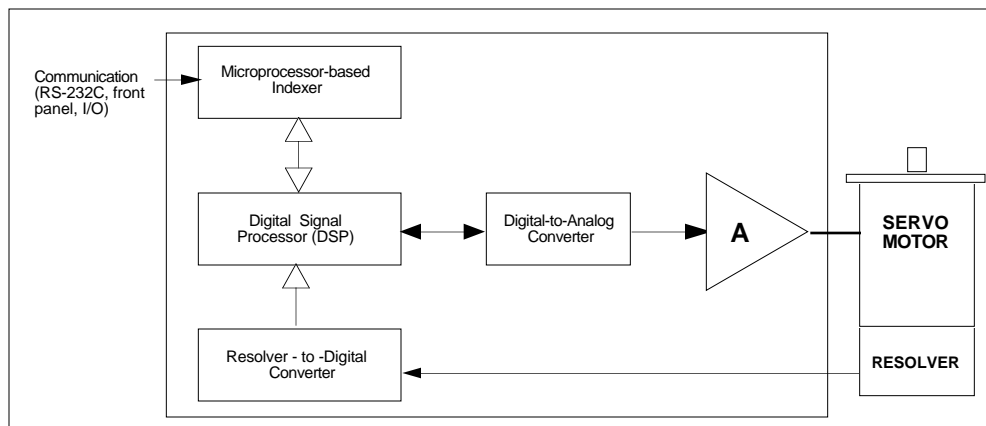

Z Drive Digital Servo System

The Z motor family consists of brushless, 3-phase, AC motors. The figure below illustrates the basic construction of the Z servo motor. The permanent magnets are securely held in place by metal bands and composite fiber materials to allow high-speed performance. The rotors are precision-balanced, which provides low- and high-speed smoothness. The windings are located in the outer portion of the motor (stator). This *inside-out* construction allows better heat dissipation than conventional brush-type motors. As a result, higher continuous torque and horsepower ratings are achieved for a given motor size.

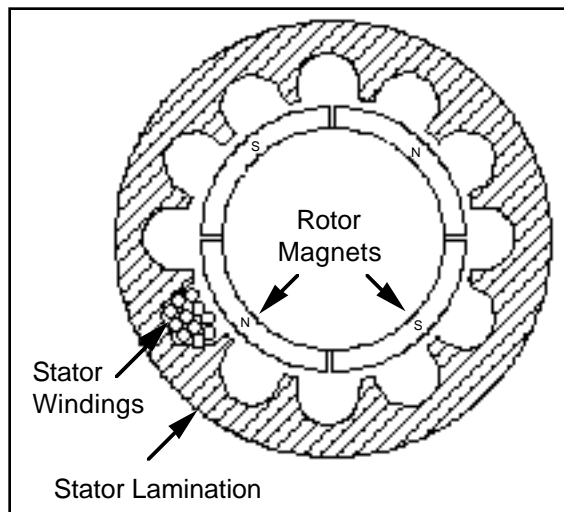

4-Pole Brushless Motor

Brushless DC refers to motors that produce a trapezoidal EMF (Electro-Motive Force) waveform. Z Drive motors are brushless AC motors that produce sinusoidal back EMF waveforms. These motors provide smoother low-speed operation than trapezoidal type motors.

The Z Drive is a 3-phase inverter that controls the amplitude, frequency, and phase of each of the three motor stator currents. Controlling the current amplitude relates directly to the magnitude of the torque being generated. Since the motor is *synchronous*, controlling the frequency of the stator currents controls the mechanical rotation of the shaft. The following equation describes this relationship.

$$\omega_e = \omega_r * (P/2)$$

- ω_e = Electrical frequency of the stator currents
- ω_r = Mechanical frequency of the shaft
- $(P/2)$ = Number of motor pole pairs

Controlling the phase of each of the motor's stator currents ensures balanced 3-phase operation and minimizes torque ripple. Actual motor currents are sensed, and the current is adjusted using pulse width modulation. Feedback is provided by a single-speed, brushless, pancake-type resolver.

The resolver is mounted directly to the motor shaft. This eliminates the need for internal coupling. The resolver stator windings are mounted to the motor housing.

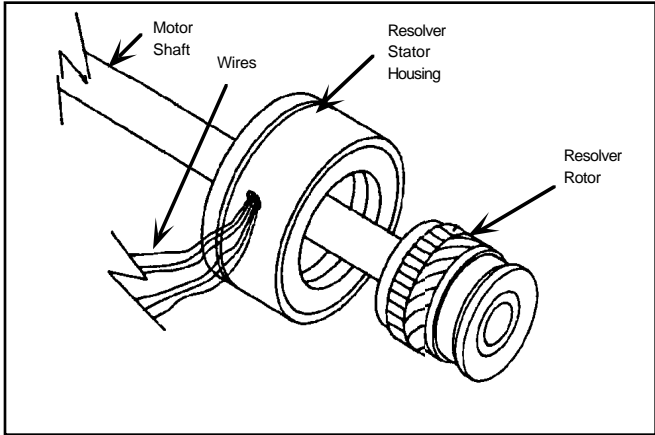

Resolver Mechanical Drawing

The figure below shows the internal windings of the resolver. Stator windings are S1/S2 and S3/S4. R1 and R2 are the rotor windings. When a voltage is excited in the rotor winding, a voltage is induced in the stator windings. The phase voltages of the stator waveforms S1/S2 and S3/S4 are compared to obtain a digital value (θ_r) representing the physical position of the motor shaft.

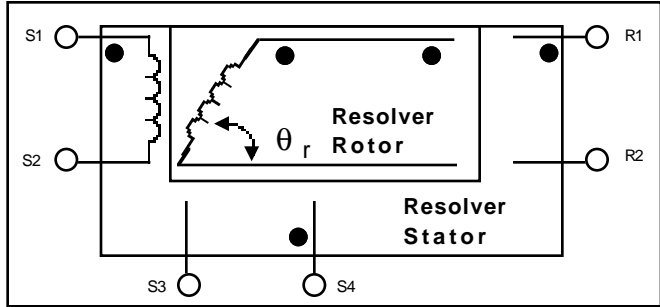

Resolver Electrical Drawing