

Compumotor

S Drive User Guide

Compumotor Division
Parker Hannifin Corporation
p/n 88-011483-01 H March 1997



IMPORTANT

User Information

To ensure that the equipment described in this User Guide, as well as all the equipment connected to and used with it, operates satisfactorily and safely, all applicable local and national codes that apply to installing and operating the equipment must be followed. Since codes can vary geographically and can change with time, it is the user's responsibility to identify and comply with the applicable standards and codes. **WARNING: Failure to comply with applicable codes and standards can result in damage to equipment and/or serious injury to personnel.**

Personnel who are to install and operate the equipment should study this user guide and all referenced documentation prior to installation and/or operation of the equipment.

In no event will the provider of the equipment be liable for any incidental, consequential, or special damages of any kind or nature whatsoever, including but not limited to lost profits arising from or in any way connected with the use of this user guide or the equipment.

© Compumotor Division of Parker Hannifin Corporation, 1997
— All Rights Reserved —

The information in this User Guide, including any apparatus, methods, techniques, and concepts described herein, are the proprietary property of Parker Compumotor or its licensors, and may not be copied, disclosed, or used for any purpose not expressly authorized by the owner thereof.

Since Parker Compumotor constantly strives to improve all of its products, we reserve the right to change this User Guide and equipment mentioned therein at any time without notice.

Technical Assistance ⇨ Contact your local automation technology center (ATC) or distributor, or ...

North America and Asia:

Compumotor Division of Parker Hannifin
5500 Business Park Drive
Rohnert Park, CA 94928
Telephone: (800) 358-9070
Fax: (707) 584-3793
FaxBack: (800) 936-6939
BBS: (707) 584-4059
e-mail: tech_help@cmotor.com

Europe (non-German speaking):

Parker Digiplan
21 Balena Close
Poole, Dorset
England BH17 7DX
Telephone: 0202-690911
Fax: 0202-600820

Germany, Austria, Switzerland:

HAUSER Elektronik GmbH
Postfach: 77607-1720
Robert-Bosch-Str. 22 • D-77656 Offenburg
Telephone: (0781) 509-0
Fax: (0781) 509-176

USER GUIDE CHANGE SUMMARY

The following is a summary of the primary changes to this User Guide since the last version was released. This User Guide, version 88-011483-01**H**, supersedes version 88-011483-01**G**.

An Appendix entitled *LVD Installation Instructions* has been added to this User Guide. The appendix contains additional procedures you must follow to install the S Drive so that it complies with the Low Voltage Directive (LVD) of the European Economic Community.



Product Type: S3, S6 and S8 Step Motor Drives

The above products are in compliance with the requirements of directives

- 72/23/EEC Low Voltage Directive
- 93/68/EEC **CE Marking Directive**

The S Drive, when installed according to the procedures in the main body of this User Guide, may not necessarily comply with the Low Voltage Directive (LVD) of the European Community. To install the S Drive so that it complies with LVD, you must follow the additional procedures described in the Appendix entitled *LVD Installation Instructions*. If you do not follow these instructions, the protection of the product may be impaired.

S Drives are sold as complex components to professional assemblers. As components, they are not required to be compliant with Electromagnetic Compatibility Directive 89/336/EEC. However, information is offered in Compumotor's *EMC Installation Guide* on how to install these drives in a manner most likely to minimize the effects of drive emissions and to maximize the immunity of drives from externally generated interference.

TABLE OF CONTENTS

How To Use This User Guide	vii
Assumptions	vii
Contents of This Manual	vii
Installation Process Overview	viii
Developing Your Application	viii
Installation Preparation	viii
Related Publications	viii
Chapter ①—Introduction	1
Product Description	1
Features	1
Chapter ②—Getting Started	3
What You Should Have	3
High-Power and Low-Power Drives	3
Quick Test	3
Attach the Motor	5
Quick Test with Indexer	6
Chapter ③—Installation	9
Installation Precautions	9
Environmental Considerations	9
Wiring Considerations	9
Preventing Electrical Noise Problems	10
DIP Switches	11
Installation Overview	12
Series vs. Parallel Motor Wiring	13
Motor Heating	13
Motor Configuration	13
Compumotor Motors—Drive/Motor Connection	13
9-Pin Motor Connector	17
Compumotor Motors—Setting Motor Current	18
Non-Compumotor Motors Drive/Motor Connection	19
Wiring Configurations	19
4-Lead Motor	19
6-Lead Motor	19
8-Lead Motor	20
Parallel Configuration	20
Series Configuration	20
Terminal Connections	21
Non-Compumotor Motors—Setting Motor Current	22
Drive Configuration	24
Automatic Standby Function	24
Motor Resolutions	24
Motor Waveforms	25
Automatic Test Function	25

Drive/Indexer Connection	26
Step & Direction Signal Specification	26
Shutdown & Set Zero Phase Signal Specification	26
Fan Connection	27
AC Power Connection	27
Transformers	28
S: Series Configuration P: Parallel Configuration	28
Testing the System	30
Drive Mounting	31
Minimum Width	31
Minimum Depth	31
Motor Mounting	32
Attaching the Load	33
Couplings	33
Tuning	34
Resonance	34
Mid-Range Instability	34
Tuning Procedures	34
Gauging Motor Resonance	35
Motor Waveforms	36
Rotary vs. Linear Indexers	37
Chapter ④—Hardware Reference	39
Environmental Specifications	39
Electrical Specifications	39
Input Power	39
Output Power	39
Output Type	39
Fault Output	39
Minimum Motor Winding Inductance	39
Maximum Motor Winding Inductance	40
Minimum Motor Hipot	40
Step & Direction Signal Specification	40
Step Pulse Input	40
Direction Input	40
Shutdown & Set Zero Phase Signal Specification	40
Shutdown Input (Amplifier Disable)	40
Set Zero Phase Input	40
Fault Output	40
Operational Specifications	41
Repeatability	41
Hysteresis	41
Rotor Inertia	41
Drive Dimensions	42
Motor Dimensions	43
DIP Switch Summary	47
Motor Performance Specifications	49

Chapter ⑤—Troubleshooting	51
Maintenance	51
Drive Maintenance	51
Motor Maintenance	51
Reducing Electrical Noise	51
Problem Isolation	52
Front Panel LEDs	52
Common Problems and Solutions	53
Testing the Motor	54
Returning the System	54
Appendix—LVD Installation Instructions	55
Complying with the Low Voltage Directive (LVD)	55
Additional Installation Procedures for LVD Compliance	55
Environmental Conditions	55
Electrical	55
Mechanical	56
Servicing the S Drive	56
Thermal Safety	57
Sonic Pressure	57
Table of Graphic Symbols and Warnings	57
Index	59

How To Use This User Guide

This User Guide is designed to help you install, develop, and maintain your system. Each chapter begins with a list of specific objectives that should be met after you have read the chapter. This section is intended to help you find and use the information in this User Guide.

Assumptions

This User Guide assumes that you have the skills or fundamental understanding of the following information.

- Basic electronics concepts (voltage, switches, current, etc.)
- Basic motion control concepts (torque, velocity, distance, force, etc.)

With this basic level of understanding, you will be able to effectively use this User Guide to install, develop, and maintain your system.

Contents of This Manual

This User Guide contains the following information.

Chapter ① Introduction

This chapter provides a description of the product and a brief account of its specific features.

Chapter ② Getting Started

This chapter contains a detailed list of items you should have received with your S Drive shipment. It will help you to become familiar with the system and ensure that each component functions properly.

Chapter ③ Installation

This chapter provides instructions for you to properly mount the system and make all electrical connections. Upon completion of this chapter, your system should be completely installed and ready to perform basic operations. Tuning considerations and procedures are also provided.

Chapter ④ Hardware Reference

This chapter contains information on system specifications (dimensions and performance). It may be used as a quick-reference tool for proper switch settings and connections.

Chapter ⑤ Troubleshooting

This chapter will help you identify and resolve system problems.

Installation Process Overview

To ensure trouble-free operation, pay special attention to the environment in which the S Drive equipment will operate, the layout and mounting, and the wiring and grounding practices used. These recommendations are intended to help you easily and safely integrate S Drive equipment into your manufacturing facility. Industrial environments often contain conditions that may adversely affect solid-state equipment. Electrical noise or atmospheric contamination, may also affect the S Drive System.

Developing Your Application

Before you attempt to develop and implement your application, there are several issues that you should consider and address.

- ① Recognize and clarify the requirements of your application. Clearly define what you expect the system to do.
- ② Assess your resources and limitations. This will help you find the most efficient and effective means of developing and implementing your application.
- ③ Follow the guidelines and instructions outlined in this user guide. Do not skip any steps or procedures. Proper installation and implementation can only be ensured if all procedures are completed in the proper sequence.

Installation Preparation

Before you attempt to install this product, you should complete the following steps:

- ① Review this entire user guide. Become familiar with the User Guide's contents so that you can quickly find the information you need.
- ② Develop a basic understanding of all system components, their functions, and interrelationships.
- ③ Complete the basic system configuration and wiring instructions (in a simulated environment, not a permanent installation) provided in *Chapter ② Getting Started*.
- ④ Perform as many basic functions as you can with the preliminary configuration. You can only perform this task if you have reviewed the entire user guide. You should try to simulate the task(s) that you expect to perform when you permanently install your application (however, do not attach a load at this time). This will give you a realistic preview of what to expect from the complete configuration.
- ⑤ After you have tested all of the system's functions and used or become familiar with all of the system's features, carefully read *Chapter ③ Installation*.
- ⑥ After you have read Chapter ③ and clearly understand what must be done to properly install the system, you should begin the installation process. Do not deviate from the sequence or installation methods provided.
- ⑦ Before you begin to customize your system, check all of the system functions and features to ensure that you have completed the installation process correctly.

The successful completion of these steps will prevent subsequent performance problems and allow you to isolate and resolve any potential system difficulties before they affect your system's operation.

Related Publications

- Current Parker Compumotor Motion Control Catalog

CHAPTER ①

Introduction

The information in this chapter will enable you to:

- Understand the product's basic functions and features

Product Description

The S Drive is a bipolar, recirculating, microstepping drive that runs two-phase permanent magnet hybrid step motors. The drive uses MOSFET technology to give high performance in a small package while providing short-circuit protection, brownout protection, over-temperature protection, and a built-in power supply. The S Drive is compatible with all Compumotor indexers.

Features

The S Drive requires no external power supply. It uses 120VAC directly for its power inputs. Compumotor's motors are two-phase hybrid motors (permanent magnet type). Four, six, or eight lead motors may be used, with the internal phases connected for parallel or series operation, provided the motor's inductance does not drop below 2 mH. *For best performance, maintain motor inductance from 5 mH - 50 mH, but motors with inductance ratings as low as 0.5 mH may be used.* You can panel mount the S Drive in a minimum depth or width configuration by moving its mounting tabs. The S Drive also provides the following features:

- Microprocessor controlled microstepping provides smooth operation over a wide range of speeds
- Short circuit protection for phase-to-phase and phase-to-ground short circuits
- Overtemperature and undervoltage protection
- Uses low-inductance motors for improved high-speed performance (23, 34, 42 frame size motors available with torques from 65 - 2,400 oz-in)
- Three state current control for reduced motor/drive heating
- LED status indicators: power, step, undervoltage, overtemperature (latched), motor fault (latched)
- Motor connector interlock to prevent connector damage
- Optically coupled step, direction, shutdown, and set zero phase inputs are compatible with all Compumotor indexers (25-pin D connector)
- A fault output to signal other equipment if a fault occurs
- High motor voltage (170VDC) operation for high-speed torque
- 90VAC - 132VAC, 50/60Hz power input
- 16 DIP switch selectable motor resolutions (200 - 50,800 steps/rev)
- Operates linear motor forcers
- 2 MHz step input

CHAPTER ②

Getting Started

The information in this chapter will enable you to:

- Verify that each component of your system has been delivered safely
- Become familiar with the system components and their interrelationships
- Ensure that each component functions properly by bench testing

What You Should Have

Inspect the S Drive upon receipt for obvious damage to its shipping container. Report any such damage to the shipping company. Parker Compumotor cannot be held responsible for damage incurred in shipment. The following items should be present and in good condition.

Part	Part Number
Power Cable (S8 has 2 cables)	44-000054-01
S Drive S6 (Low) or S8 (High)*	
S Drive User Guide	88-011483-01A
Motor	Variety of sizes available**

*The S8 Drive includes a fan kit

**Refer to subsequent tables in this chapter for specific motor sizes

High-Power and Low-Power Drives

You should verify which type of S Drive you have before proceeding with this chapter. The high-power version of the drive (**S8**) provides bipolar 0 - 8 amps/phase (up to 2,400 oz-in). The low-power version of the drive (**S6**) provides bipolar 0 - 6 amps/phase (up to 400 oz-in). You can determine which drive you have by checking the label on the side of the drive. The label identifies the unit as **S8 DRIVE** or **S6 DRIVE**. You must be aware of the drive's type to set the motor current correctly (using DIP switches). There are different DIP switch settings for the two drive types. If you did not receive the drive type that you ordered, please call your local Automation Technology Center (ATC) or distributor.

Quick Test

This section will show you how to set the S Drive's DIP switches and wire the unit to quickly ensure that your system is operating properly. Detailed installation instructions are provided in *Chapter ③ Installation*. You will need the following tools to complete these steps:

- A Phillips head screw driver (to move mounting brackets)
- A flat screw driver (to adjust DIP switches and make connections)

CAUTION

Never adjust the DIP switches with a pencil.
Lead from the pencil may contaminate the drive.

The figure below shows the location of the S Drive's DIP switches.

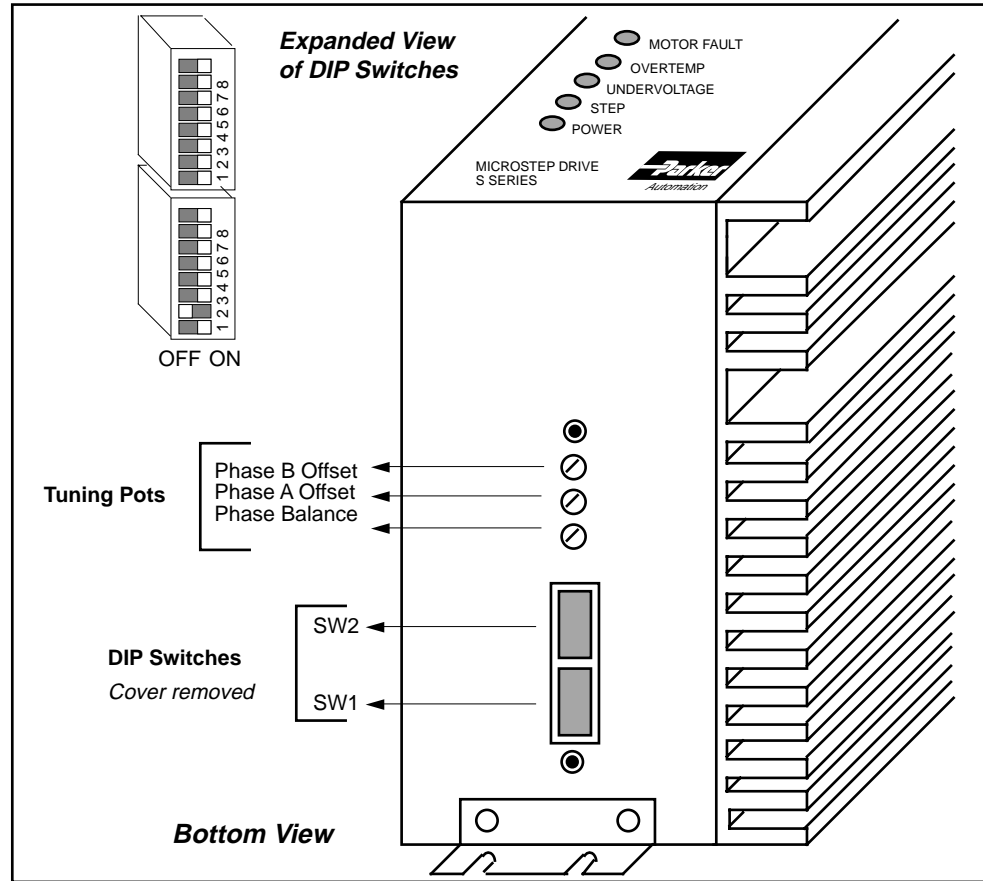

DIP Switch & Tuning Pot Locations

① Set DIP Switches

The S Drive has two sets of DIP switches. Each set of DIP switches has eight individual switches. The first set of switches will be referred to as **SW1** and the second set as **SW2**. The individual switch will be preceded by the # symbol. Hence, the third switch on **SW1** will be referred to as **SW1-#3**, while the third switch on **SW2** will be referred to as **SW2-#3**.

The first thing that you must do is set the motor current on the S Drive to match the motor that you are using. Use the directions below to set the DIP switches for your motor. (Drive/Motor systems are shipped from the factory with the motor current set for that system. Drive-only products are shipped from the factory with the motor current set at the minimum current level.)

- ① **Be sure that power is not applied to the unit.**
- ② Remove the panel that covers the DIP switches.
- ③ Set the motor current for your Compumotor using the following tables: **SW1-#1** thru **SW1-#6 control motor current**. Make the required adjustments to match the drive and motor types that you are using.

Motor Size	Current	SW1-#1	SW1-#2	SW1-#3	SW1-#4	SW1-#5	SW1-#6
S57-51S	1.18	off	off	on	on	off	off
S57-51P	2.28	off	on	on	off	off	off
S57-83S	1.52	off	on	off	off	off	off
S57-83P	3.09	on	off	off	off	off	off
S57-102S	1.71	off	on	off	off	on	off
S57-102P	3.47	on	off	off	on	off	off
S83-62S	2.19	off	on	off	on	on	on
S83-62P	4.42	on	off	on	on	on	off
S83-93S	2.85	off	on	on	on	on	off
S83-93P	5.62	on	on	on	off	on	on
S83-135S	3.47	on	off	off	on	off	off
S83-135P	6.00	on	on	on	on	on	on

S: Series Configuration P: Parallel Configuration

Setting S6 Motor Current (S Series Compumotor Motors)

Motor Size	Current	SW1-#1	SW1-#2	SW1-#3	SW1-#4	SW1-#5	SW1-#6
S106-178S	6.02	on	off	on	on	on	on
S106-178P	8.0	on	on	on	on	on	on
S106-205S	3.55	off	on	on	on	off	off
S106-205P	6.99	on	on	off	on	on	on
S106-250S	6.02	on	off	on	on	on	on
S106-250P	8.0	on	on	on	on	on	on

S: Series Configuration P: Parallel Configuration

Setting S8 Motor Current (S Series Compumotor Motors)

The previous tables show motor current settings for series and parallel motor configurations. Refer to *Chapter 3 Installation* for specific motor configuration instructions. **Compumotor ships all S Drive systems in series configurations.**

If you use a *non-Compumotor motor*, special precautions and instructions are required. Read the instructions in *Chapter 3 Installation* for non-Compumotor motors thoroughly before attempting to set the motor current or wire your motor.

- ④ To test the system, you will use the Automatic Test function. **DIP switch SW2-#8 controls this function.** Turn **SW2-#8 on** to enable the function. The Automatic Test function rotates the motor in an Alternating mode approximately 6 revolutions at 1 rps (12 inches at 2 ips if a L20 Linear Motor is used).
- ⑤ After you have properly set motor current (**SW1-#1** thru **SW1-#6**) and the Automatic Test function (**SW2-#8**), screw the plate that covers the DIP switches back onto the drive. **Do not change any other DIP switch settings.**

② Attach the Motor

WARNING

POWER MUST BE OFF before cabling the drive.
Lethal voltages are present inside the drive and on its screw terminals.
 When connecting the motor to the drive, be sure the connector is firmly seated.

The S Drive motor is pre-wired in series. Plug the pre-wired motor cable into the **Motor** connector on the drive. If you use a non-Compumotor motor, refer to *Chapter 3 Installation* for instructions on wiring the motor to the drive. **Do not connect the motor to the load at this time.**

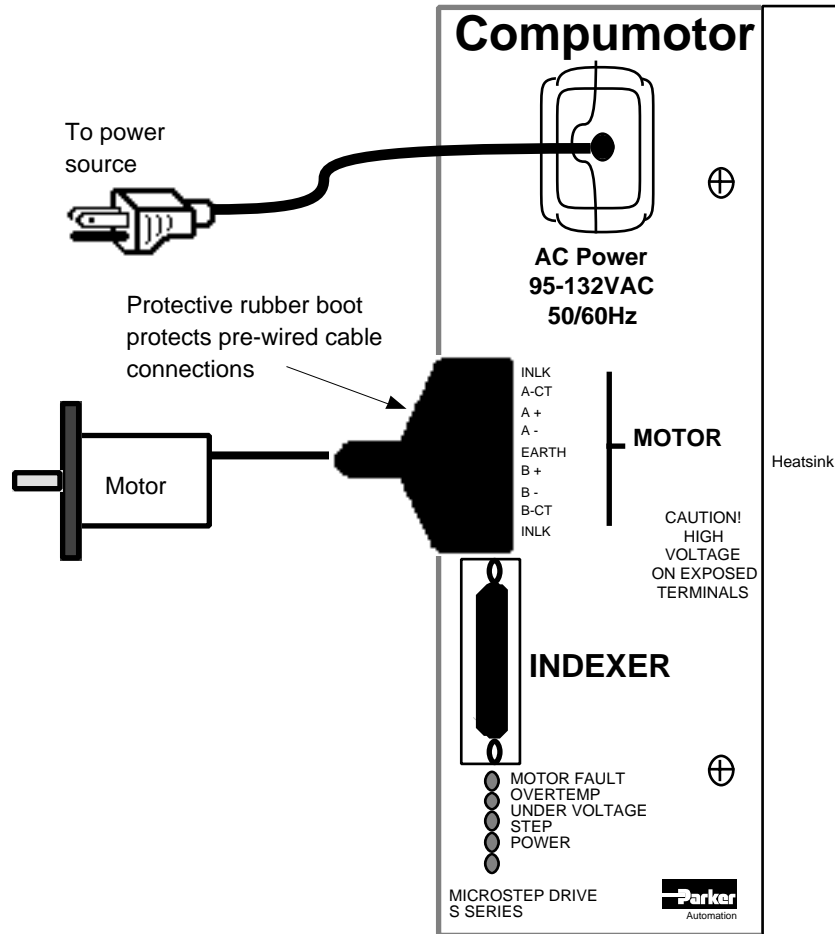

Test Configuration (S6 Drive Shown)

③ Apply Power

The power cable is a pre-wired, molded AC cord. Complete the following steps to apply power.

- ① Plug the pre-wired cable into the power connector on the drive.
- ② Plug the other end of the cable into a 115VAC power source. *If you are using the S8 Drive (high power), you must also plug in the fan's power cable to 115VAC. The fan must be on when power is applied to the drive.* The motor should rotate in an Alternating mode approximately 6 revolutions at 1 rps. The **green** Power LED should be on.
- ③ **To stop the motor, you must unplug the power cable from the power source. The motor may continue to run for a few seconds after you remove power.**

The successful completion of this test indicates that the amplifier, motor, and microprocessor are operating properly. You can now test the indexer interface (the Step, Direction, and Shutdown inputs). Be sure that power is not applied to the system when you begin. To perform this test, complete the following steps.

Quick Test with Indexer

With no power applied to the drive, perform the following steps to test the indexer interface. This test assumes that your indexer's motor resolution is set to 25,000 steps/rev. This is the default motor resolution setting for the S Drive.

- ① Remove the panel that covers the DIP switches. Turn DIP switch **SW2-#8 off** to disable the Automatic Test function. Ensure that switches **SW2-#1** through **SW2-#4** are **off**. **Do not change any other DIP switch settings.** Screw the panel back onto the drive.

- ② Connect your Compumotor indexer to the drive's 25-pin D indexer connector. The appropriate cable is provided with the indexer.
- ③ Ensure that the pre-wired motor cable that you connected in the previous test is still connected. Apply power to the drive and indexer.

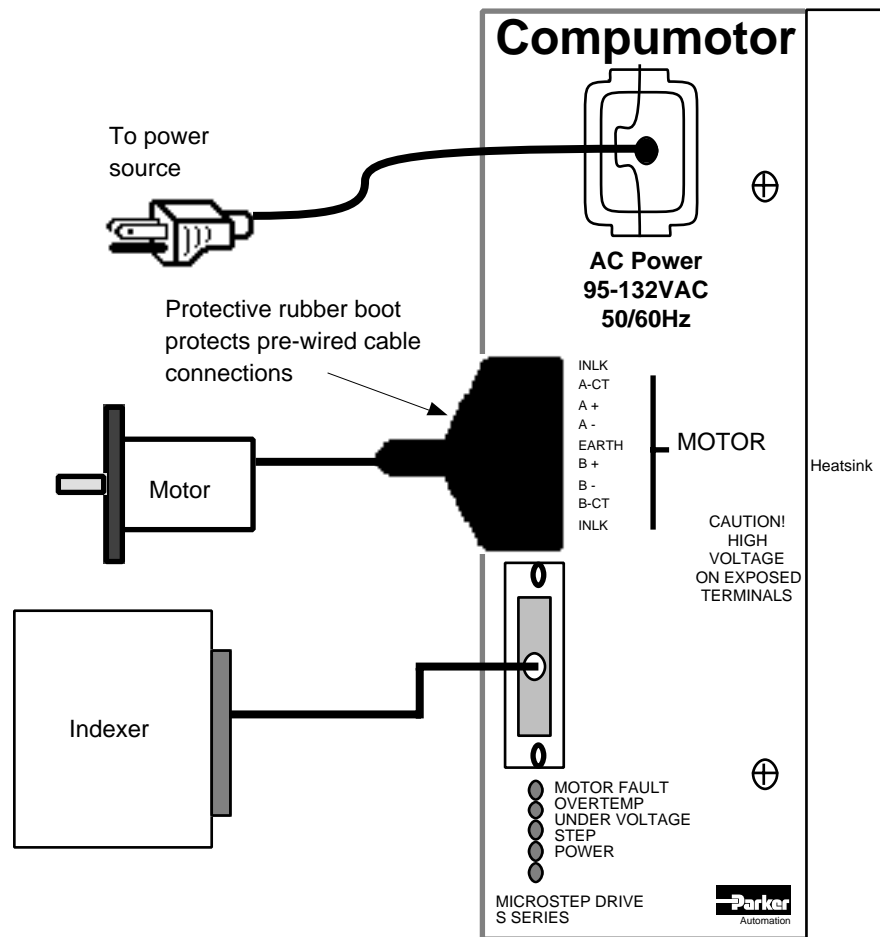

Test Configuration (S6 Drive Shown)

- ④ Using the indexer, send step pulses to the drive that will rotate the motor one **CW** revolution (25,000 step pulses) at an acceleration of 1 rps² and a velocity of 1 rps (25,000 steps per second).
When the drive receives the step pulses, the motor should rotate one **CW** revolution. The **green** Power LED and the **green** step LED should be on when the drive is receiving pulses.
- ⑤ Using the indexer, send step pulses to the drive that will rotate the motor one **CCW** revolution at an acceleration of 1 rps² and a velocity of 1 rps (25,000 steps per second).
When the drive receives the step pulses, the motor should rotate one **CCW** revolution. The **green** Power LED is on when power is applied to the drive and the **green** step LED should be on when the drive is receiving pulses. (This LED will flicker during low step rates and shine more brightly at higher step rates.)
- ⑥ Now you will test the Shutdown input. With no step pulses applied to the drive, activate the Shutdown input. Refer to your indexer's operations manual for instructions on activating the Shutdown input.
By activating the Shutdown input, all current will be removed from the motor. You should be able to turn the motor shaft manually. Try to turn the shaft slowly now. If you can turn it easily, the Shutdown input is working properly. If the shaft still has torque, check your wiring and try the test again.

CHAPTER ③

Installation

The information in this chapter will enable you to:

- Ensure that the complete system is installed correctly
- Mount all system components properly

Before proceeding with this chapter, you should have completed the steps and procedures in *Chapter ② Getting Started*.

Installation Precautions

This section contains precautions that you must follow to configure and operate your S Drive system properly.

Environmental Considerations

An internal thermostat will shut down the drive if it reaches 158°F (70°C) internally. Current settings in excess of 4A in high ambient temperature environments (above 113°F [45°C]) may require fan cooling to keep the heatsink temperature within allowable limits and to keep the drive from shutting itself down due to overtemperature. *The maximum allowable motor case temperature is 212°F (100°C). Actual temperature rise is duty cycle dependent.*

CAUTION

When connected in parallel, S Drive motors can overheat if operated at high speeds for extended periods of time.

Wiring Considerations

There are hazardous voltages present on the S Drive's connectors when power is applied. To prevent injuries to personnel and damage to equipment, note the following guidelines:

- Never connect/disconnect the motor from the drive when power is applied. If you do, the motor connector may be damaged. Power should never be applied to the drive when the motor is not connected.
- Never increase the current setting (using the drive's DIP switches) to more than 10% greater than the current specified for the motor you are using. Excessive current may cause the motor to overheat and result in a motor failure.
- Verify that there are no wire *whiskers* that can short out the motor connections. If the motor turns the wrong direction after you connect the motor wires to the connector and the connector to the drive, you can change the direction by reversing the leads going to **A+** and **A-** on the motor terminal.

- Never extend the **INLNK** jumper beyond the connector. This jumper protects the motor connector and should **not** be used as a system interlock.
- **Never** probe the drive. **Never** connect anything other than the motor to the motor terminals. Probing or opening the drive in any other way will void the warranty. Hazardous voltages are present within the drive. **The thermal interface will be broken if you open the drive. The thermal interface is critical to the reliability of the drive.**

Grounding

Proper grounding of electrical equipment is essential to ensure safety. You can reduce the effects of electrical noise due to electromagnetic interference (EMI) by grounding. All Compumotor equipment should be properly grounded. Refer to the National Electrical Code published by the National Fire Protection Association of Boston, MA for more information on grounding requirements.

In general, all components and enclosures must be connected to earth ground through a grounding electrode conductor to provide a low-impedance path for ground fault or noise-induced currents. All earth ground connections must be continuous and permanent. Compumotor recommends a single-point grounding setup. Prepare components and mounting surfaces prior to installation so that good electrical contact is made between mounting surfaces of equipment and enclosure. Remove the paint from equipment surfaces where the ground contact will be bolted to a panel and use star washers to ensure solid, bare metal contact.

For temporary installation, or when you cannot implement the grounding method described above, connect the GND terminal on the AC power connector to earth ground. Whenever possible, route high-power signals (i.e., motor and power) away from logic signals (i.e., step and direction, RS-232C, RS-422/485, parallel output) to prevent electrical noise problems.

Preventing Electrical Noise Problems

The S Drive provides power to the motor by switching 170VDC (120VAC input) at 21 KHz (nominal). This has the potential to radiate or conduct electrical noise along the motor cable, through the motor, and into the frame to which the motor is attached. It can also be conducted out of the drive into the AC power line. Use the following steps to prevent problems caused by electrical noise generated by the S Drive:

- ① Ground the motor casing (*already done for you with Compumotor motors*).

WARNING

You must ground the motor casing. Motor winding case capacitance can cause large potentials to develop at the motor. This can create a lethal shock hazard.

- ② Avoid extended motor cable runs. Mount the drive as close as is practical to the motor.
- ③ Mount equipment that is sensitive to electrical noise as far as possible from the S Drive and motor.
- ④ Filter power to the S Drive with a PI type filter and an isolation transformer (refer to the power ratings later in this chapter). The filter reduces the AC line noise that the S Drive generates back into the AC line. The Corcom® EP Series filter works well with the S Drive.
Corcom
1600 Winchester Road
Libertyville, IL 60048 Telephone: (847) 680-7400
- ⑤ Provide a separate power line for the S Drive. Do not use the same power circuit for equipment that is sensitive to electrical noise and the S Drive.
- ⑥ Shield the motor cable in conduit and ensure the conduit is taken to a low impedance earth ground.

DIP Switches

The S Drive has two sets of DIP switches (refer to the figure below). Each set of DIP switches has eight individual switches. The first set of switches is referred to as **SW1** and the second set as **SW2**. The individual switch will be preceded by the # symbol. Hence, the third switch on **SW1** is referred to as **SW1-#3**, while the third switch on **SW2** is referred to as **SW2-#3**.

To modify any of the drive's switch settings, **remove power from the drive** and follow the steps below.

- ① Remove the panel that covers the DIP switches.
- ② Make the required adjustments.
- ③ Screw the panel back into place over the switches.

The S Drive recognizes changes to its switch settings during power up only.

WARNING

Never adjust switches with power applied to the unit.
Hazardous voltages are contained within the drive when power is applied.

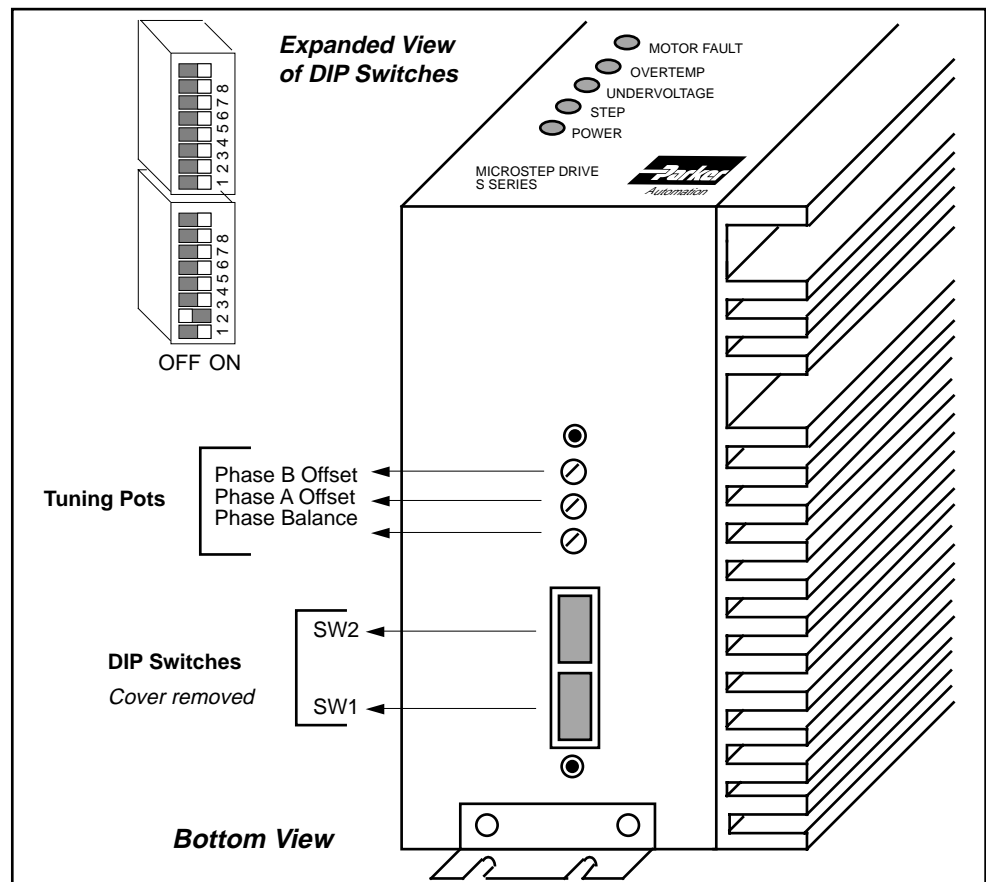

DIP Switch & Tuning Pot Locations

Installation Overview

The procedures in this chapter will enable you to configure and wire your system. The following graphic shows the front panel of the S Drive. The following installation steps will be discussed:

- ① Series vs. Parallel Motor Wiring
- ② Motor/S Drive Configuration (Wiring & Motor Current)
 - Compumotor Motors
 - Non-Compumotor Motors
- ③ Set Other DIP Switches
- ④ Wire Indexer to S Drive
- ⑤ Fan connection (*for S6 —fan is standard for S8*)
- ⑥ Apply Power to S Drive
- ⑦ Test the System
- ⑧ Mount the S Drive and the motor
- ⑨ Attach the Load

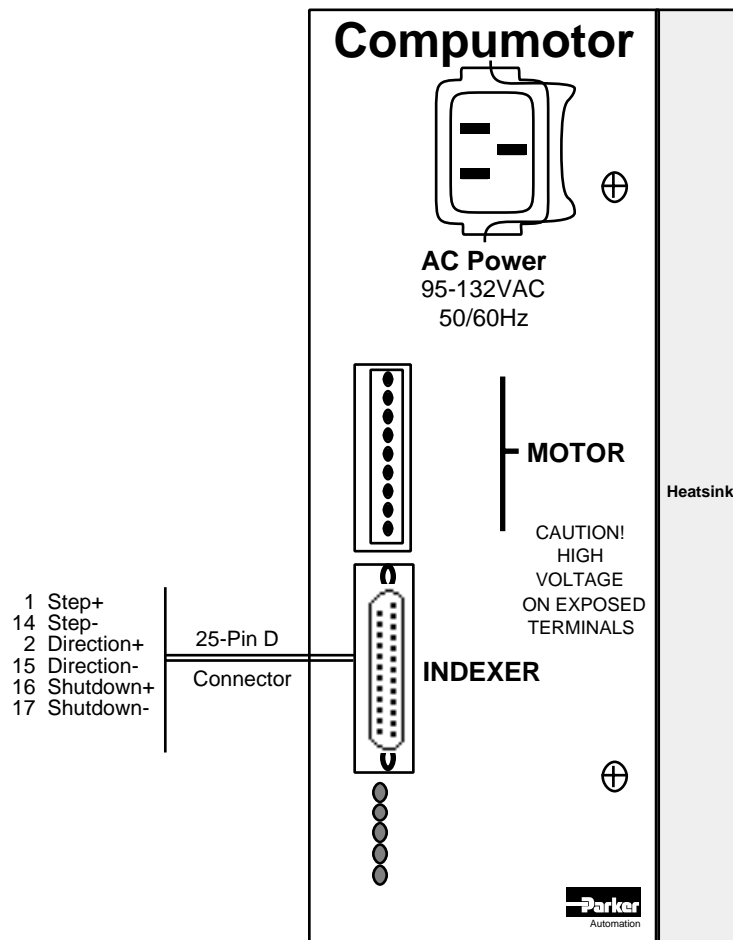

S Drive Wiring Diagram (S6 Drive Shown)

Do not deviate from the steps in this chapter. Do not wire or apply power to the system until you are instructed to do so. If you do not follow these steps, you may damage your system.

① Series vs. Parallel Motor Wiring

S Series motors are shipped from the factory wired in series. You may re-wire the motor (shown later in this chapter—*Wiring Configurations*). Parallel configurations provide more torque than series configurations provide at high speeds (refer to the speed/torque curves in *Chapter ④ Hardware Reference*). You must observe certain precautionary measures to prevent overheating when using motors wired in parallel configurations (refer to *Non-Compumotor—Drive/Motor Connection* later in this chapter).

Motor Heating

S Series motors that are wired in series can be run continuously at speeds that incur peak motor loss. S Series motors that are wired in parallel, however, cannot be run at peak motor loss levels continuously without overheating (unless extensive cooling measures are employed). Most applications do not require continuous slewing at high speed. Therefore, the average motor loss will be within safe limits.

② Motor Configuration

The S Drive can run Compumotor and Non-Compumotor motors. This section provides instructions for configuring Compumotor and Non-Compumotor motors. **Follow only the directions that apply to the type of motor that you are using.**

Compumotor Motors—Drive/Motor Connection

Compumotor motors are pre-wired in series and require no setup other than being plugged into the drive. If you plan to run the motor in series, no further motor wiring setup is required.

Your S Drive's motor connector may be a 7-pin or 9-pin connector. Follow the instructions that apply to your connector only.

Frame size 23 and 34 motors (S57 or S83) are 8 lead motors. Frame size 42 (S106) are 4 lead motors. The graphic below represents the motor winding color code for 8 lead, 23 and 34 frame size motors.

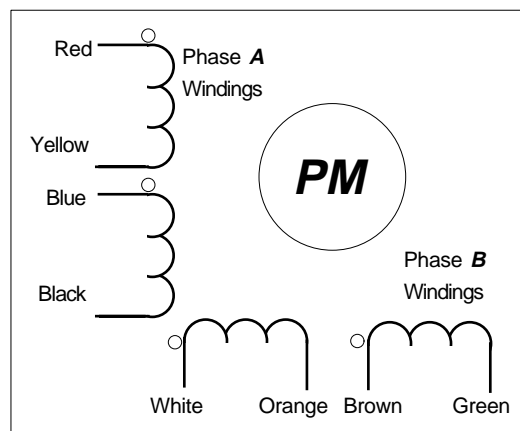

8-Lead Motor Winding Color Code

S Series motors in the 23 and 34 frame sizes (S57 and S83 series) are constructed with an 8 conductor motor cable to allow you to change the motor configuration on the connector at the drive. The 42 frame size motors (S106 series) are constructed with a 4-lead motor cable, but the motors can be configured by removing the cover plate on the back of the motor and rewiring at the screw terminals.

S106-178 Series and Parallel Connections

The S106-178 is pre-wired in series. If you remove the motor's back panel, you can wire it in parallel.

Series and Parallel

Motor Terminal #	Wire Color
1	Red
3	Black
5	Green
4	White

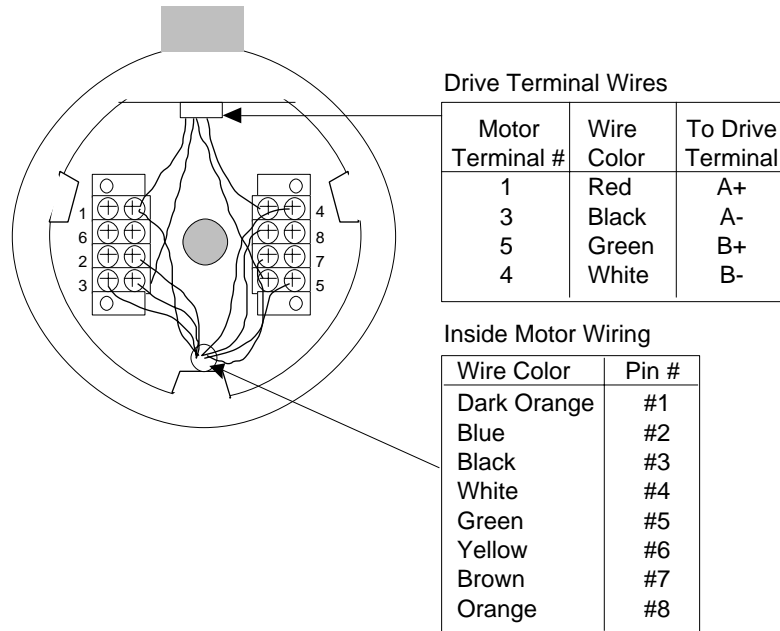

S106-178 Motor Wiring Diagram

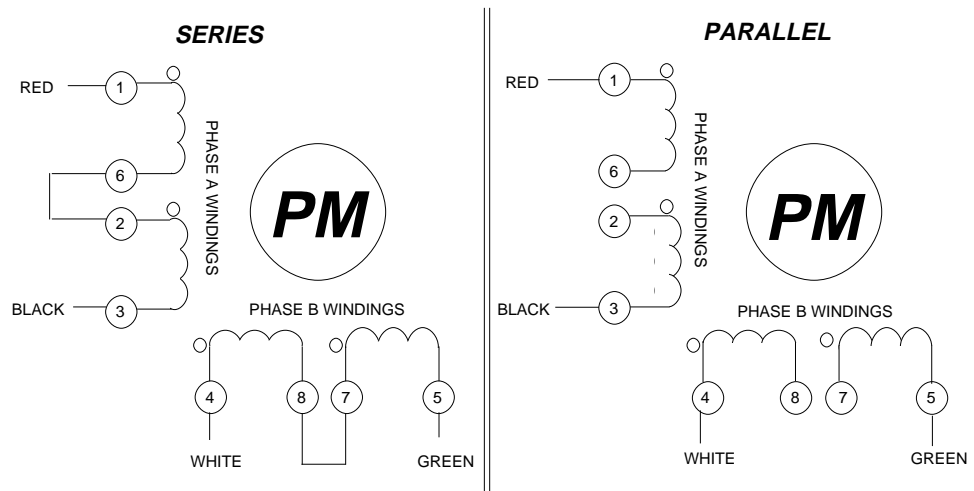

S106-178 Series and Parallel Connections

S106-205 Series and Parallel Connections

The S106-205 is pre-wired in series. If you remove the motor's back panel, you can wire it in parallel.

Series and Parallel

Motor Terminal #	Wire Color
1	Red
3	Green
5	Black
4	White

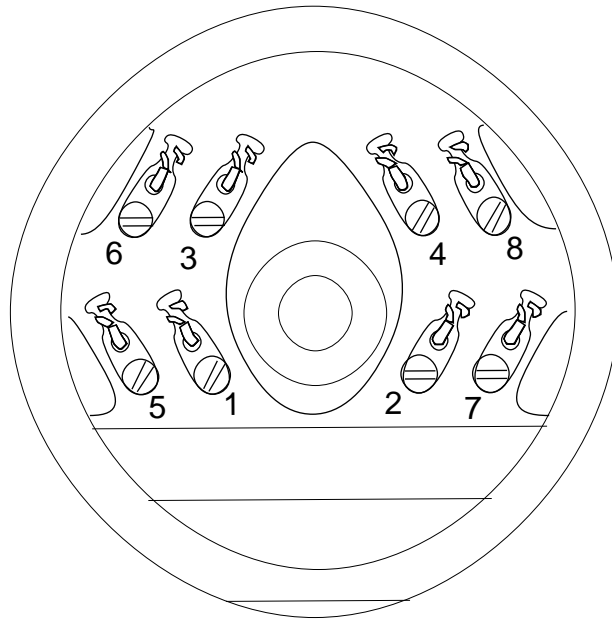

S106-205 Motor Wiring Diagram

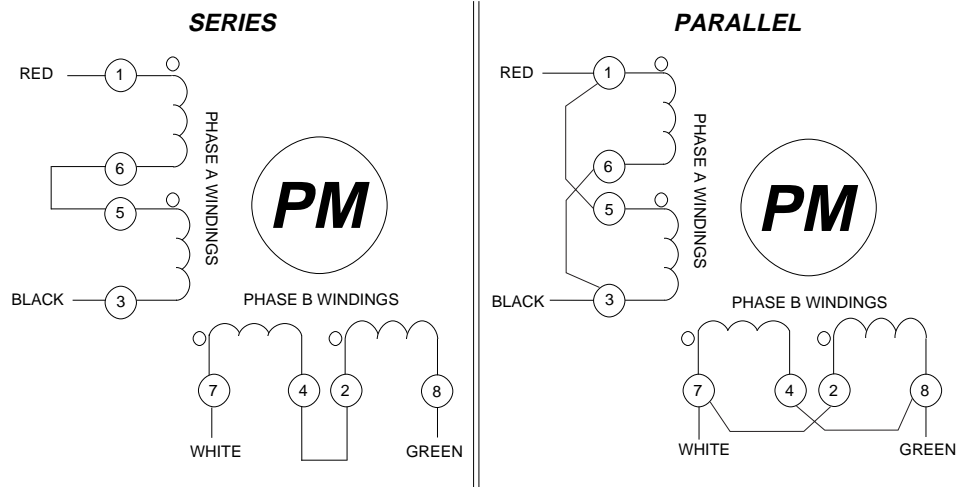

S106-205 Series and Parallel Connections

S106-250 Series and Parallel Connections

The S106-250 is pre-wired in series. If you remove the motor's back panel, you can wire it in parallel.

Series and Parallel

Motor Terminal #	Wire Color
1	Red
3	Black
4	White
5	Green

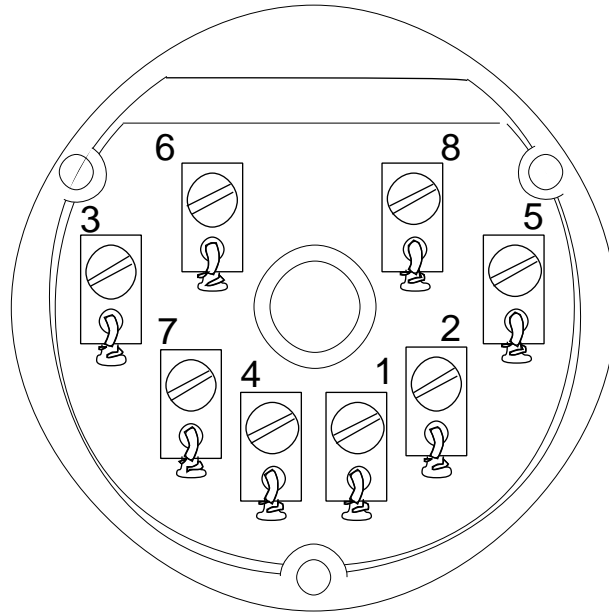

S106-250 Motor Wiring Diagram

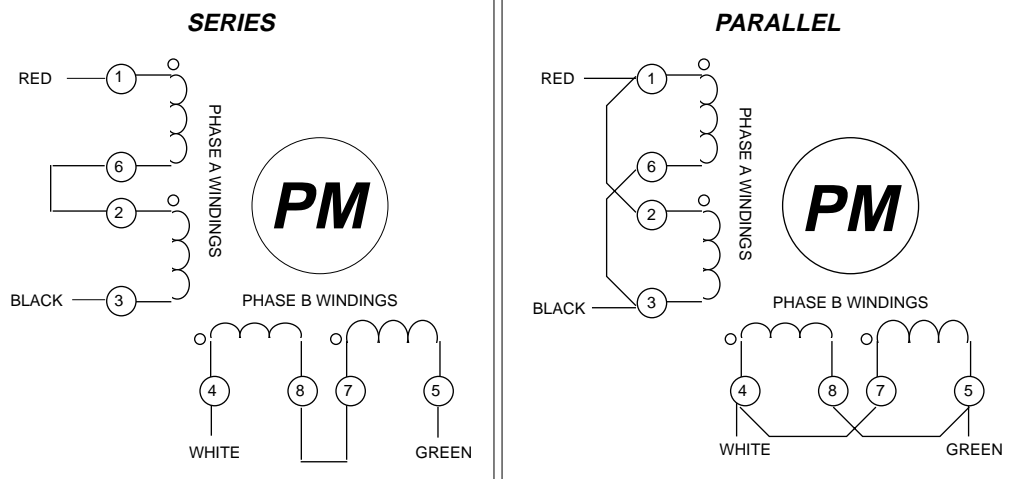

S106-250 Series and Parallel Connections

9-Pin Motor Connector

The *9-pin version* of the **MOTOR** connector is shown below. Before connecting the motor, determine which motor wires correspond to Phase A and Phase B. The 9-pin motor connector provides for easier installation when the motor is wired in series. **A-CT** and **B-CT** are not connections—they are terminal blocks.

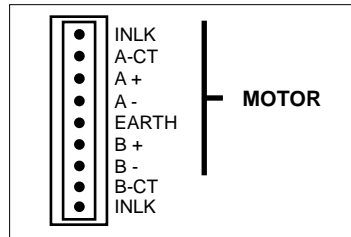

S Drive 9-Pin Motor Connector

The following tables show the color codes for the following types of motor connections to the S Drive 9-pin **MOTOR** connector.

- 8 Lead Motors—Series (S57 and S83)
- 8 Lead Motors—Parallel (S57 and S83)
- 4 Lead Motors—Series or Parallel (S106)

Pin	Color
A-CT	Yellow & Blue
A+	Red
A-	Black
EARTH	Shield
B+	White
B-	Green
B-CT	Orange & Brown
Jumper INLK to INLK	

Color Code—9-Pin Connector/8 Lead Motor (Series)

Pin	Color
A-CT	N.C.
A+	Red & Blue
A-	Black & Yellow
EARTH	Shield
B+	White & Brown
B-	Green & Orange
B-CT	N.C.
Jumper INLK to INLK	

Color Code—9-Pin Connector/8 Lead Motor (Parallel)

Pin	Color
A-CT	N.C.
A+	Red
A-	Black
EARTH	Shield
B+	White
B-	Green
B-CT	N.C.
Jumper INLK to INLK	

Color Code—9-Pin Connector/4Lead Motor (S & P)

Once you determine the wiring configuration, connect the motor to the drive's screw terminals according to the appropriate color code table. The following instructions should also be completed.

- ① Connect shield to the **MOTOR** connector's shield. **This is a very important safety precaution.** If your motor does not have a ground (shield) wire, attach a lug to the motor case and connect the motor to **EARTH**.
- ② Connect a short jumper wire from **INLK** (first pin of connector) to **INLK** (last pin of connector). This is a connector interlock. The drive will not operate if this jumper is missing or extended.

Extended Motor Cables

The table below contains the recommended motor cables for various motor types and the minimum recommended motor/driver wire size (AWG) and resistance.

Motor Series	Maximum Current Per Winding (Amps)	Less than 100 ft. (20.5M)	100 - 200 ft. (30.5M - 71M)
S57	3	22 AWG	20 AWG
S83	6	20 AWG	18 AWG
S106	8	16 AWG	14 AWG

Recommended Motor Cables

Cable runs of more than 200 feet (71M) are not recommended. Cable runs greater than 50 feet may degrade system performance.

Compumotor Motors—Setting Motor Current

You should verify which type of S Drive you have before setting motor current. The high-power drive (**S8**) provides bipolar 0 - 8 amps/phase (up to 2,400 oz-in). The low-power drive (**S6**) provides bipolar 0 - 6 amps/phase (up to 400 oz-in). You can determine which drive you have by checking the label on the side of the drive. The label identifies the unit as **S8 DRIVE** or **S6 DRIVE**. You must be aware of the drive's type to set the motor current correctly (using DIP switches). The tables below contain the proper motor current settings for Compumotor motors. **SW1-#1** through **SW1-#6** control *motor current*. Adjust the motor current to match the drive and motor that you are using. A complete list of all current motor current settings is provided in *Chapter ④ Hardware Reference*.

Motor Size	Current	SW1-#1	SW1-#2	SW1-#3	SW1-#4	SW1-#5	SW1-#6
S57-51S	1.18	off	off	on	on	off	off
S57-51P	2.28	off	on	on	off	off	off
S57-83S	1.52	off	on	off	off	off	off
S57-83P	3.09	on	off	off	off	off	off
S57-102S	1.71	off	on	off	off	on	off
S57-102P	3.47	on	off	off	on	off	off
S83-62S	2.19	off	on	off	on	on	on
S83-62P	4.42	on	off	on	on	on	off
S83-93S	2.85	off	on	on	on	on	off
S83-93P	5.62	on	on	on	off	on	on
S83-135S	3.47	on	off	off	on	off	off
S83-135P	6.00	on	on	on	on	on	on

S: Series Configuration P: Parallel Configuration

S6 Drive Motor Current (Compumotor Motors)

Motor Size	Current	SW1-#1	SW1-#2	SW1-#3	SW1-#4	SW1-#5	SW1-#6
S106-178S	6.02	on	off	on	on	on	on
S106-178P	8.0	on	on	on	on	on	on
S106-205S	3.55	off	on	on	on	off	off
S106-205P	6.99	on	on	on	on	on	on
S106-250S	6.23	on	on	off	off	off	on
S106-250P	8.0	on	on	on	on	on	on

S: Series Configuration P: Parallel Configuration

S8 Drive Motor Current (Compumotor Motors)

Non-Compumotor Motors Drive/Motor Connection

Compumotor does not recommend that you use non-Compumotor motors with the S Drive. If you do use a non-Compumotor motor, it must meet the following requirements:

- A minimum inductance of 2 mH, series or parallel, may be used (Compumotor recommends a minimum inductance of 5 mH).
- A minimum of 500VDC high-pot insulation rating from phase-to-phase and phase-to-ground.
- The motor must not have riveted rotors or stators.
- Do not use solid rotor motors.
- Test all motors carefully. Verify that the motor temperature in your application is within the system limitations. *The motor manufacturer's maximum allowable motor case temperature must not be exceeded.* You should test the motor over a 2- to 3-hour period. Motors tend to have a long thermal time constant, but can still overheat, which results in motor damage.

CAUTION

Consult a Compumotor Applications Engineer if you intend to use a non-Compumotor motor.

Wiring Configurations

You can determine the motor's wiring configuration by referencing the manufacturer's motor specification document supplied with the motor. You can also determine the wiring configuration with an ohmmeter using the procedures below (*4-Lead Motor*, *6-Lead Motor*, *8 Lead Motor*). Once you determine the correct motor wiring configuration, use the terminal connection diagram that applies to your configuration (refer to the *Terminal Connections* section later in this chapter).

4-Lead Motor

- ① Label one motor lead **A+**.
- ② Connect one lead of an ohmmeter to the **A+** lead and touch the other lead of the ohmmeter to the three remaining motor leads until you find the lead that creates continuity. Label this lead **A-**.
- ③ Label the two remaining leads **B+** and **B-**. Verify that there is continuity between the **B+** and **B-** leads.
- ④ Proceed to the *Terminal Connections* section below.

6-Lead Motor

- ① Determine, with an ohmmeter, which three of the six motor leads are common (one phase).
- ② Label each one of these three motor leads **A**.
- ③ Using the ohmmeter, verify that the remaining three leads are common.
- ④ Label the other three leads **B**.
- ⑤ Set the ohmmeter range to approximately the 100 ohm scale.
- ⑥ Connect the negative lead of the ohmmeter to one of the motor leads labeled **A**. Alternately measure the resistance to the two remaining motor leads also labeled **A**. The resistance measurements will reflect one of the following scenarios:

👉 **Helpful Hint: Scenario #1**

The resistance measurements to the two remaining motor leads are virtually identical. Label the two remaining motor leads **A+** and **A-**. Label the motor lead connected to the negative lead of the ohmmeter **A-CT** (this is the center tap lead for Phase A of the motor).

Helpful Hint: Scenario #2

The resistance measurement to the second of the three motor leads measures 50% of the resistance measurement to the third of the three motor leads. Label the second motor lead **A-CT** (this is the center tap lead for Phase A of the motor). Label the third motor lead **A-**. Label the motor lead connected to the ohmmeter **A+**.

- ⑦ Repeat the procedure as outlined in step 6 for the three leads labeled **B** (**B-CT** is the center tap lead for Phase B of the motor).
- ⑧ *If your S Drive has a 7-pin motor connector*, cover the two motor leads labeled **A-CT** and **B-CT** with electrical tape or shrink tubing to prevent these leads from shorting out to anything else. Do not connect these leads together or to anything else.
If your S Drive has a 9-pin motor connector, connect the **A-CT** motor lead to the **A-CT** pin on the **MOTOR** connector. Connect the **B-CT** motor lead to the **B-CT** pin on the **MOTOR** connector.
- ⑨ Proceed to the *Terminal Connections* section below.

8-Lead Motor

Because of the complexity involved in phasing an 8-lead motor, you must refer to the manufacturer's motor specification document. You can configure the 8-lead motor in parallel or series. Using the manufacturer's specifications, label the motor leads as shown in the *Terminal Connections* section.

Parallel Configuration

Use the following procedures for parallel configurations.

- ① Connect motor leads A1 and A3 and relabel this common point **A+**.
- ② Connect motor leads A2 and A4 and relabel this common point **A-**.
- ③ Connect motor leads B1 and B3 and relabel this common point **B+**.
- ④ Connect motor leads B2 and B4 and relabel this common point **B-**.

Series Configuration

Use the following procedures for series configurations.

- ① *If your S Drive has a 7-pin motor connector*, connect the motor leads labeled A2 and A3 together and cover this connection with electrical tape or shrink tubing. Make sure these leads are not connected to the S Drive.
If your S Drive has a 9-pin motor connector, you can connect A2 and A3 to **A-CT**. You may also connect B2 and B3 to **B-CT**.
- ② Relabel the A1 lead to **A+**.
- ③ Relabel the A4 lead to **A-**.
- ④ *If your S Drive has a 7-pin motor connector*, connect the motor leads labeled B2 and B3 together and cover this connection with electrical tape or shrink tubing. Make sure these leads are not connected to the S Drive.
- ⑤ Relabel the B1 lead to **B+**.
- ⑥ Relabel the B4 lead to **B-**.
- ⑦ Proceed to the *Terminal Connections* section the next page.

Terminal Connections

After determining the motor's wiring configuration, connect the motor leads to the 9-pin or 7-pin **MOTOR** connector using the diagrams below.

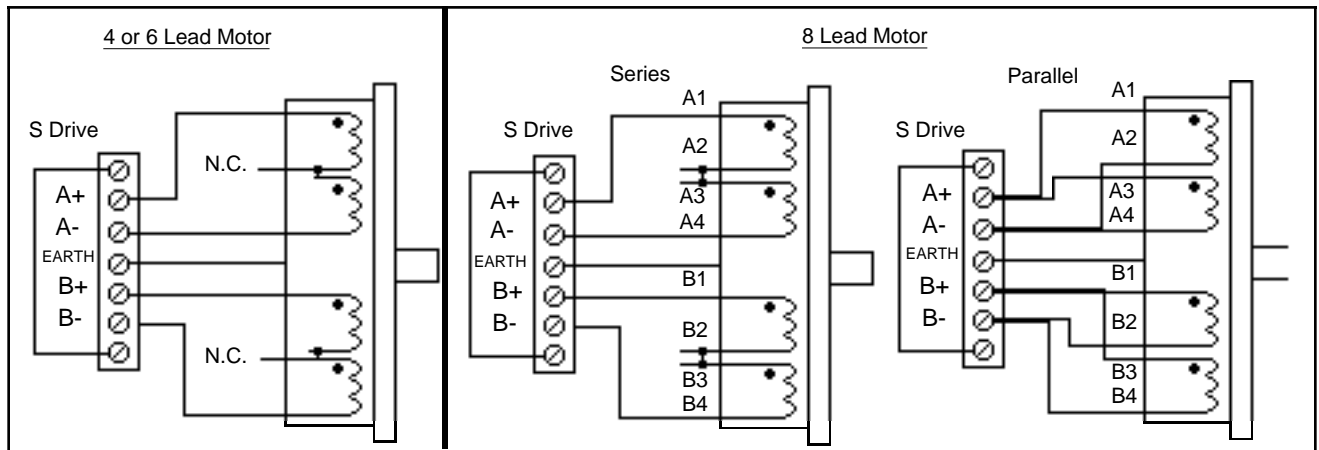

7-Pin Motor Connector (Non-Compumotor Motors)

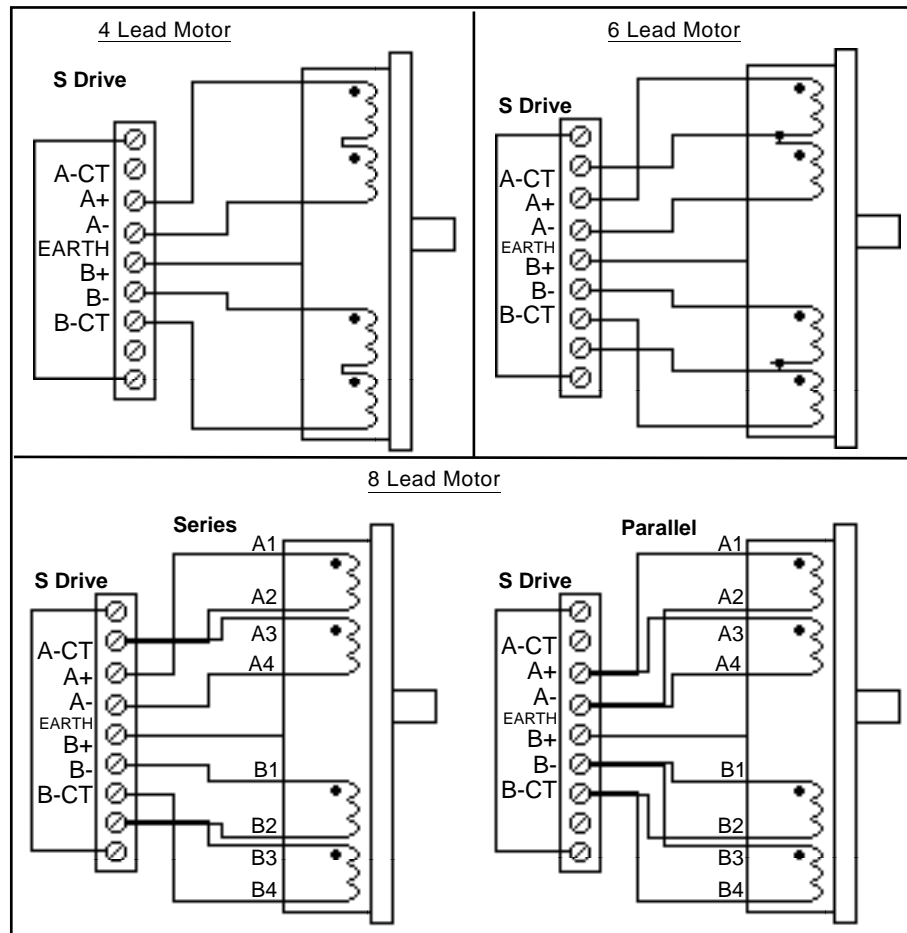

9-Pin Motor Connector (Non-Compumotor Motors)

CAUTION

Do not connect or disconnect the motor with the power on.
This will damage the contacts of the motor connector and may cause personal injury.

Extended Motor Cables

The table below contains the recommended motor cables for various motor types and the minimum recommended motor/driver wire size (AWG) and resistance.

Motor Series	Maximum Current Per Winding (Amps)	Less than 100 ft. (20.5M)	100 - 200 ft. (30.5M - 71M)
S57	3	22 AWG	20 AWG
S83	6	20 AWG	18 AWG
S106	8	16 AWG	14 AWG

Recommended Motor Cables

Cable runs of more than 200 feet (71M) are not recommended. Cable runs greater than 50 feet may degrade system performance.

Non-Compumotor Motors—Setting Motor Current

Compumotor does not recommend that you use non-Compumotor motors with the S Drive. If you do, refer to the formulas below that correspond to your motor (4-lead, 6-lead, or 8-lead) and use the S6/S8 motor current tables to set motor current. **Never increase current more than 10% above the specified rating.**

4-Lead Motors

If you use a 4-lead motor, the manufacturer's current setting will translate directly to the values shown in the S6/S8 motor current tables.

6-Lead Motors

If you use a 6-lead motor, and the manufacturer specifies the motor current as a unipolar rating, you must use the following formula to convert the unipolar current rating to the correct bipolar rating.

Unipolar Current X .707 = Bipolar Current

After you make the conversion, use S6/S8 motor current tables to set motor current. If the manufacturer specifies the motor current as a bipolar rating, you can use the motor current tables on the next page directly (no conversion) to set motor current.

8-Lead Motors

If you are using an 8-lead motor, manufacturers generally rate the motor current in one of two ways:

- If the motor current is listed as a unipolar rating, use the following formula to convert the unipolar current rating to the correct bipolar current rating.

Unipolar Current X .707 = Bipolar Series Current

If you are wiring the motor in *series*, use the motor current tables on the next page and the converted value to set the motor current.

If you wire the motor in *parallel*, you must **double** the converted value and use Table 3-11 or 3-12 to set the motor current.

- If the motor current is listed as a bipolar series rating, you can wire the motor in *series* and use the motor current tables on the next page directly (no conversion) to set motor current.

If the motor current is listed as a bipolar series rating and you wire the motor in *parallel*, you must **double** the manufacturer's rating and then use the motor current tables on the next page to set the motor current.

If you have any questions with regard to the configurations, please call Compumotor's Applications Engineering Department at 800-358-9070.

Low-Power S6 Drive

Current	SW1	SW2	SW3	SW4	SW5	SW6	Current	SW1	SW2	SW3	SW4	SW5	SW6
0.04	off	off	off	off	off	off	3.09	on	off	off	off	off	off
0.13	off	off	off	off	off	on	3.19	on	off	off	off	off	on
0.23	off	off	off	off	on	off	3.28	on	off	off	off	on	off
0.32	off	off	off	off	on	on	3.38	on	off	off	off	on	on
0.42	off	off	off	on	off	off	3.47	on	off	off	on	off	off
0.51	off	off	off	on	off	on	3.57	on	off	off	on	off	on
0.61	off	off	off	on	on	off	3.66	on	off	off	on	on	off
0.70	off	off	off	on	on	on	3.76	on	off	off	on	on	on
0.80	off	off	on	off	off	off	3.85	on	off	on	off	off	off
0.89	off	off	on	off	off	on	3.95	on	off	on	off	off	on
0.99	off	off	on	off	on	off	4.04	on	off	on	off	on	off
1.08	off	off	on	off	on	on	4.14	on	off	on	off	on	on
1.18	off	off	on	on	off	off	4.23	on	off	on	on	off	off
1.27	off	off	on	on	off	on	4.33	on	off	on	on	off	on
1.37	off	off	on	on	on	off	4.42	on	off	on	on	on	off
1.46	off	off	on	on	on	on	4.51	on	off	on	on	on	on
1.52	off	on	off	off	off	off	4.58	on	on	off	off	off	off
1.62	off	on	off	off	off	on	4.68	on	on	off	off	off	on
1.71	off	on	off	off	on	off	4.77	on	on	off	off	on	off
1.81	off	on	off	off	on	on	4.86	on	on	off	off	on	on
1.90	off	on	off	on	off	off	4.96	on	on	off	on	off	off
2.00	off	on	off	on	off	on	5.05	on	on	off	on	off	on
2.09	off	on	off	on	on	off	5.15	on	on	off	on	on	off
2.19	off	on	off	on	on	on	5.24	on	on	off	on	on	on
2.28	off	on	on	off	off	off	5.34	on	on	on	off	off	off
2.38	off	on	on	off	off	on	5.43	on	on	on	off	off	on
2.47	off	on	on	off	on	off	5.53	on	on	on	off	on	off
2.57	off	on	on	off	on	on	5.62	on	on	on	off	on	on
2.66	off	on	on	on	off	off	5.72	on	on	on	on	off	off
2.76	off	on	on	on	off	on	5.81	on	on	on	on	off	on
2.85	off	on	on	on	on	off	5.91	on	on	on	on	on	off
2.95	off	on	on	on	on	on	6.00	on	on	on	on	on	on

Setting S6 Drive Motor Current (Non-Compumotor Motors)

High-Power S8 Drive

Current	SW1	SW2	SW3	SW4	SW5	SW6	Current	SW1	SW2	SW3	SW4	SW5	SW6
0.05	off	off	off	off	off	off	4.12	on	off	off	off	off	off
0.18	off	off	off	off	off	on	4.25	on	off	off	off	off	on
0.30	off	off	off	off	on	off	4.38	on	off	off	off	on	off
0.43	off	off	off	off	on	on	4.50	on	off	off	off	on	on
0.56	off	off	off	on	off	off	4.63	on	off	off	on	off	off
0.69	off	off	off	on	off	on	4.75	on	off	off	on	off	on
0.81	off	off	off	on	on	off	4.89	on	off	off	on	on	off
0.93	off	off	off	on	on	on	5.01	on	off	off	on	on	on
1.06	off	off	on	off	off	off	5.14	on	off	on	off	off	off
1.19	off	off	on	off	off	on	5.26	on	off	on	off	off	on
1.31	off	off	on	off	on	off	5.39	on	off	on	off	on	off
1.44	off	off	on	off	on	on	5.51	on	off	on	off	on	on
1.59	off	off	on	on	off	off	5.64	on	off	on	on	off	off
1.69	off	off	on	on	off	on	5.77	on	off	on	on	off	on
1.82	off	off	on	on	on	off	5.90	on	off	on	on	on	off
1.94	off	off	on	on	on	on	6.02	on	off	on	on	on	on
2.03	off	on	off	off	off	off	6.11	on	on	off	off	off	off
2.16	off	on	off	off	off	on	6.23	on	on	off	off	off	on
2.28	off	on	off	off	on	off	6.36	on	on	off	off	on	off
2.41	off	on	off	off	on	on	6.48	on	on	off	off	on	on
2.54	off	on	off	on	off	off	6.61	on	on	off	on	off	off
2.66	off	on	off	on	off	on	6.73	on	on	off	on	off	on
2.79	off	on	off	on	on	off	6.87	on	on	off	on	on	off
2.91	off	on	off	on	on	on	6.99	on	on	off	on	on	on
3.04	off	on	on	off	off	off	7.12	on	on	on	off	off	off
3.17	off	on	on	off	off	on	7.24	on	on	on	off	off	on
3.297	off	on	on	off	on	off	7.37	on	on	on	off	on	off
3.42	off	on	on	off	on	on	7.49	on	on	on	off	on	on
3.55	off	on	on	on	off	off	7.62	on	on	on	on	off	off
3.67	off	on	on	on	off	on	7.75	on	on	on	on	off	on
3.80	off	on	on	on	on	off	7.87	on	on	on	on	on	off
3.93	off	on	on	on	on	on	8.00	on	on	on	on	on	on

Setting S8 Drive Motor Current (Non-Compumotor Motors)

③ Drive Configuration

In this section, you will set the following DIP switch selectable functions:

- Auto Standby function
- Motor Resolutions
- Motor Waveforms
- Auto Run function

Automatic Standby Function

The Automatic Standby function allows the motor to cool when it is not moving. This function reduces the current to the motor when the drive does not receive a step pulse for one second. Switches **SW1-#7** through **SW1-#8** control Automatic Standby. Full power is restored upon the first step pulse that the drive receives. *Do not use this function in systems that use an indexer and an encoder for position maintenance. If used in this environment, the system will go in and out of the Auto Standby mode.*

Current	SW1-#7	SW1-#8
* Full Current	off	off
75%	on	off
50%	off	on
25%	on	on

* Default Setting

Automatic Standby Function

Motor Resolutions

Switches **SW2-#1** - **SW2-#4** control motor resolution. **Your indexer and drive must be set to the same resolution.** If the drive and indexer's motor resolution settings do not match, commanded accelerations and velocities will not be performed accurately.

Resolution	SW2-#1	SW2-#2	SW2-#3	SW2-#4
50,800 steps	off	off	off	on
50,000 steps	off	off	on	off
36,000 steps	off	off	on	on
25,600 steps	off	on	off	off
25,400 steps	off	on	off	on
* 25,000 steps	off	off	off	off
21,600 steps	off	on	on	off
20,000 steps	off	on	on	on
18,000 steps	on	off	off	off
12,800 steps	on	off	off	on
10,000 steps	on	off	on	off
5,000 steps	on	off	on	on
2,000 steps	on	on	off	off
1,000 steps	on	on	off	on
400 steps	on	on	on	off
200 steps	on	on	on	on

* Default Setting

Motor Resolution Settings

Motor Waveforms

Motor Waveforms help you to overcome resonance problems and allow the motor to run smoothly. DIP switches **SW2-#5** through **SW2-#7** control the waveform shape. *This function will not operate when the 200- and 400-step motor resolutions are used.*

Waveform Shape	SW2-#5	SW2-#6	SW2-#7
Pure Sine	on	on	off
-2% 3rd harmonic	on	off	on
* -4% 3rd harmonic	off	off	off
-4% 3rd harmonic	on	on	on
-4% 3rd harmonic	on	off	off
-6% 3rd harmonic	off	on	on
-8% 3rd harmonic	off	on	off
-10% 3rd harmonic	off	off	on

* *Default Setting*

Motor Waveform Settings

Automatic Test Function

The Automatic Test (*DIP switch SW2-#8*) function turns the motor shaft slightly less than six revolutions in Alternating mode at 1 rps. The Automatic Standby function and motor resolution settings are disabled when you use the Automatic Test function.

* SW2-#8 OFF Disables Auto Test
SW2-#8 ON Enables Auto Test

* *Default Setting*

④ Drive/Indexer Connection

 **Helpful Hint: For drive/indexer wiring instructions, refer to *Installation Overview***

If you are using a Compumotor indexer, plug the indexer cable into the S Drive's **INDEXER** connector. If you are using a non-Compumotor indexer, the indexer must meet the specifications listed below.

Step & Direction Signal Specification

The inputs are optically isolated and may be driven (activated) by applying a positive pulse to the *plus* input with respect to the *minus* input (refer to input schematic below.). These inputs may also be differentially driven. The input driver must provide a minimum of 6.5 mA (15 mA maximum).

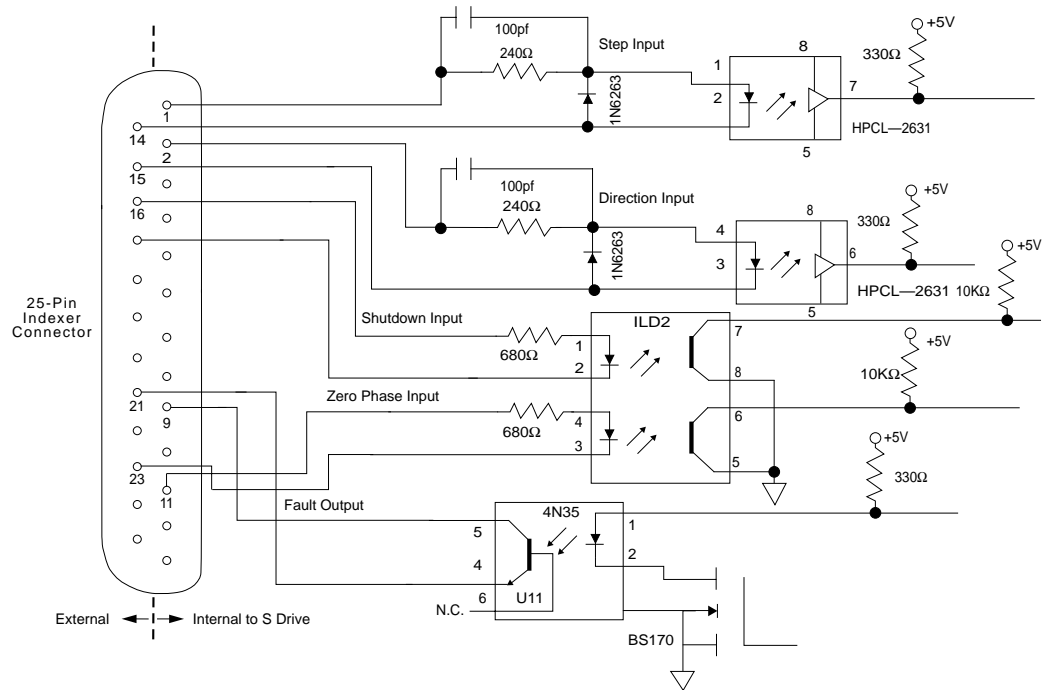

S Drive I/O Schematic

Step Pulse Input

You must operate the step pulse input within the following guidelines.

- 200 nanosecond-pulse minimum
- 40% - 60% duty cycle (2 MHz max pulse rate)

Direction Input

The direction input may change polarity coincident with the last step pulse. The direction input must be stable for at least 2 ms before the drive receives the first pulse.

Shutdown & Set Zero Phase Signal Specification

The inputs are optically isolated and may be driven (activated) by providing a positive pulse to the *plus* input with respect to the *minus* input. *The input driver must provide a minimum of 2.5 mA (30 mA maximum). The maximum reverse voltage for this input is 3VDC.*

Shutdown Input (Amplifier Disable)

You may enable this function when the motor is not moving. The input must be active for 100 ms to disable the amplifier. The **SHUTDOWN** input must be inactive for 100 ms before the first step pulse is received.

Set Zero Phase Input

This input allows you to reset the motor phase currents to the power up position. It is primarily for linear motor applications. The input must be active for 100 ms to reset the motor phase currents to the zero state. The SET ZERO PHASE input must be inactive for 100 ms before the first step pulse is received.

Fault Output

This output is an open-collector, open emitter output from a 4N35 OPTO isolator. The output transistor will conduct when the drive is functioning properly. The transistor will not conduct when any of the following conditions exist:

- No power is applied to the drive
- There is insufficient AC line voltage (90VAC)
- The drive temperature is too high
- The drive detects a motor fault
- The Shutdown input is enabled

Helpful Hint: Output Electric Parameters

This output has the following characteristics:

- $V_{CE} = 35\text{VDC}$
- $V_{CESAT} = 0.3\text{VDC}$
- Collector Current = 10 mA minimum
- Dissipation = 100 mW maximum

⑤ Fan Connection

The fan kit is a standard feature of the **S8** (high-power) Drive. If you are using the **S6** (low-power) Drive, you may order the fan kit from your ATC or Compumotor Distributor. *Ensure that the fan is always on when the S8 Drive is on.*

⑥ AC Power Connection

Helpful Hint: Refer to the Installation Overview for more on the power connection

The S Drive includes a standard molded power cable. Simply plug the power cable into the fan kit's power connector and a 90VAC - 132VAC power source.

CAUTION

AC power to the S Drive is limited to 132VAC.
Higher voltages will damage the drive. The low-voltage limit is 90VAC.

Transformers

An isolation transformer (optional) can enhance the system’s electrical noise immunity. Refer to the *Transformer Specifications* section for instructions on sizing a transformer for your application. Use the transformer user guide and the diagram below to connect the transformer leads to the AC power connector on the drive.

WARNING

Do not connect the transformer to the S Drive while power is applied to the transformer.
Do not touch the wiring studs or terminals on the transformer after it is plugged into an AC outlet. Lethal voltages are present.

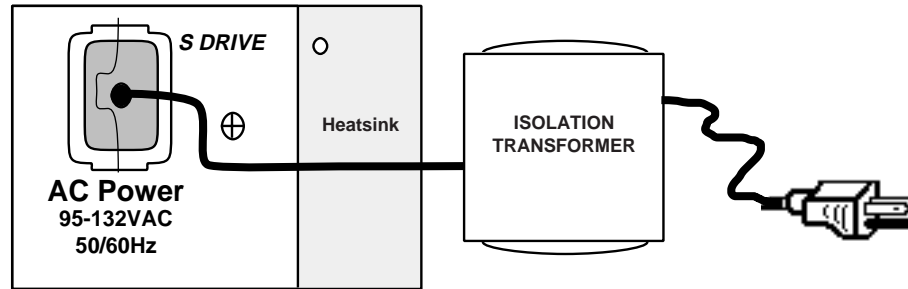

Transformer Connections

Transformer Specifications

The tables below contain data to help system designers cool drives and motors, and size isolation transformers. Each of the tables’ fields is explained below. Combinations of motors and current levels other than those discussed in this section will result in power values that are not specified in this discussion.

Helpful Hint: S Drive Power Ratings

S Series motors are shipped in series. You may re-wire the motor (see Wiring Configurations). Parallel configurations provide more torque than series configurations provide at high speeds. You must use precautionary measures to prevent overheating when motors wired in parallel configurations are used (see *Non-Compumotor—Drive/Motor Connection*).

Motor Type	Current (Amps)	Cabinet Loss (Watts)	Peak Motor Loss (Watts)	Peak Shaft Power (Watts)	Peak Total Power (Watts)	Volt-Amp Rating (VA)
S57-51S	1.15	11.2	25	55	90	140
S57-51P	2.30	15.8	50	110	180	270
S57-83S	1.55	12.7	27	72	110	170
S57-83P	3.1	19.8	54	144	218	335
S57-102S	2.0	14.5	30	95	140	215
S57-102P	4.0	25.1	60	190	280	420
S83-62S	2.0	14.5	50	120	190	280
S83-62P	4.0	25.1	100	240	370	560
S83-93S	2.8	18.2	52	172	240	370
S83-93P	5.6	36.6	104	343	480	740
S83-135S	3.45	21.8	57	205	280	440
S83-135P	6.0*	40.0	114	410	560	870

S: Series Configuration P: Parallel Configuration * S83-135P motors can be driven at 7A with an S8 Drive

S6 Drive Power Ratings

Motor Type	Cabinet Loss (Watts)	Peak Motor Loss (Watts)	Peak Shaft Power (Watts)	Peak Total Power (Watts)	Volt-Amp Rating (VA)
S106-178S	20	140	350	510	790
S106-178P	30	280	700	1010	1570
S106-205S	40	290	460	790	1230
S106-250S	30	160	360	550	860
S106-250P	40	300	700	1040	1620

S: Series Configuration P: Parallel Configuration

S8 Drive Power Ratings

☞ Helpful Hint: *Calculations*

- To convert watts to horsepower, **divide by 746**.
- To convert watts to BTU/hr, **multiply by 3.413**.
- To convert watts to BTU/min, **multiply by 0.0569**.

Motor Type

Compumotor S Series motors are custom-made for use with S Drives. They are not available as a standard model from any other manufacturer. These motors are designed for low loss at rest and at high speed. Motors in the same frame sizes from other manufacturers may sustain considerably higher iron losses than an S Series motor. S Series motors are wound to render inductances within a particular range suitable for S Drives. If you intend to use a motor other than an S Series motor, you should consult Compumotor's Applications Engineering Department for motor heating and drive performance consequences (800-358-9068). The S Drive is intended for use with 2 phase PM step motors only. Do not use variable inductance or DC motors.

Current (Amps)

Compumotor has assigned the current ratings shown in the previous tables for S Series motors to produce the highest possible torque while maintaining smoothness. Use of higher currents will produce higher static torque; however, the motor will run rough and may overheat. The selected current setting for a motor wired in parallel is twice the value of the current setting selected for that motor wired in series. Do not run the parallel rated current into a motor that is wired in series—it will destroy the motor's windings.

Cabinet Loss

The total thermal dissipation in the S Drive is almost constant, regardless of whether the motor is stationary or in motion. The current output switch settings determine the motor phase currents that cause power losses. The cabinet's thermal resistance is approximately 0.35°C/W in still air with the heatsink fins vertically positioned. For 6A operation, the cabinet will rise approximately 15°C above ambient temperature. The fan kit (which is optional for S6 Drives) will reduce this temperature rise to 2°C. End item design must prevent ambient temperature around the drive from exceeding 50°C (temperatures above 50°C will activate the drive's thermal shutdown feature). If the appropriate temperature cannot be maintained, the fan kit must be installed.

Peak Motor Loss

As the speed of a motor increases, the *core losses* (hysteresis and eddy current) increase to the level where the motor loses torque. The peak dissipation includes core and copper losses. The data shown in *Drive Power Rating* tables above do not indicate average power unless the motor is run almost continuously at high speed. Average motor loss will generally be less than these figures depending on the duty cycle and dwell times. Motor losses are almost entirely independent on the mechanical load. ***Motor losses are not related to shaft power.***

S Series motors that are wired in series can be run continuously at speeds that incur peak motor loss. S Series motors that are wired in parallel, however, cannot be run at peak motor loss levels continuously without overheating (unless extensive cooling measures are employed). Most applications do not require continuous slewing at high speed. Therefore, the average motor loss will be within safe limits (refer to the motor sizing information provided in Compumotor's sizing software).

Do not run the S Drive with motors in a parallel configuration without inspecting the thermal behavior of the system. A parallel motor that operates at peak motor loss does not sustain damage immediately. Approximately 10 - 30 minutes of continuous operation may be required to reveal an overheating problem. In general, the motor's case temperature should not exceed 100°C.

Peak Shaft Power

Peak shaft power is the product of torque and velocity in the region where the speed/torque curve appears as a hyperbola. In that speed range, available shaft power is essentially constant at this peak value. Most applications don't use more than 50% of the available peak shaft power. Use the peak shaft power values shown in the *Drive Power Rating* tables to determine the maximum demand on the primary power source.

Peak Total Power

Peak total power is the sum of cabinet loss + peak motor loss + peak shaft power (refer to *S Drive Power Tables*). The average demand will be significantly less than the values provided in the tables depending on duty cycles at high speed and dwell times at rest.

Volt-Amp Rating

S Drives obtain DC power by directly rectifying 120VAC, 60 Hz voltage. This is a low-cost, light-weight, small-size method of obtaining power. However, such a power supply represents a low-power factor to the line (± 0.65 for S Drives). The volt-amp ratings provided in the *Drive Power Rating* tables were calculated by dividing *peak total power* by 0.65.

Summary

Selecting an isolation transformer based on these will provide you with a conservatively rated system. For slow-speed or light-duty applications, smaller VA ratings may be appropriate.

7 Testing the System

With no power applied to the drive, perform the following steps to test your installed S Drive system.

- ① Ensure that all DIP switches are properly set for the motor and indexer that you are using.
 - Motor Current
 - Automatic Standby Function
 - Motor Resolution (must match indexer)
 - Motor Waveform
 - Automatic Test Function (should be off)
- ② Check your connections. Ensure that the system is properly configured.
- ③ **Apply power to the system** (*if you have a high-power drive—S8, be sure to power up the drive and the fan*).
- ④ Using the indexer, send step pulses to the drive that will rotate the motor one **CW** revolution at an acceleration of 1 rps² and a velocity of 1 rps.
When the drive receives the step pulses, the motor should rotate one **CW** revolution. The **green POWER** LED and the **green STEP** LED should be on when the drive receives pulses.
- ⑤ Using the indexer, send step pulses to the drive that will rotate the motor one **CCW** revolution at an acceleration of 1 rps² and a velocity of 1 rps.
When the drive receives the step pulses, the motor should rotate one **CCW** revolution. The **green POWER** LED and the **green STEP** LED should be on when the drive receives pulses.
- ⑥ Now you will test the Shutdown input. With no step pulses applied to the drive, activate the Shutdown input. Refer to your indexer's operations manual for instructions on activating the Shutdown input.
By activating the Shutdown input, all current will be removed from the motor. You should be able to turn the motor shaft manually. Try to turn the shaft slowly now. If you can turn it easily, the Shutdown input is working properly. If the shaft still has torque, check your wiring and try the test again.

⑧ Drive Mounting

You can mount the S Drive in a minimum depth or width configuration, depending on the position of the mounting clips. *Use only 6-32 X 1/4" screws to attach the mounting clips. Longer screws may damage the drive.*

Minimum Width

Two clips are attached to the side of the drive away from the power connectors for minimum width. This provides the maximum amount of panel space. **The drive is shipped in this configuration.**

Minimum Depth

You can move the clips from the minimum width position to the side opposite the heatsink to create a minimum depth configuration.

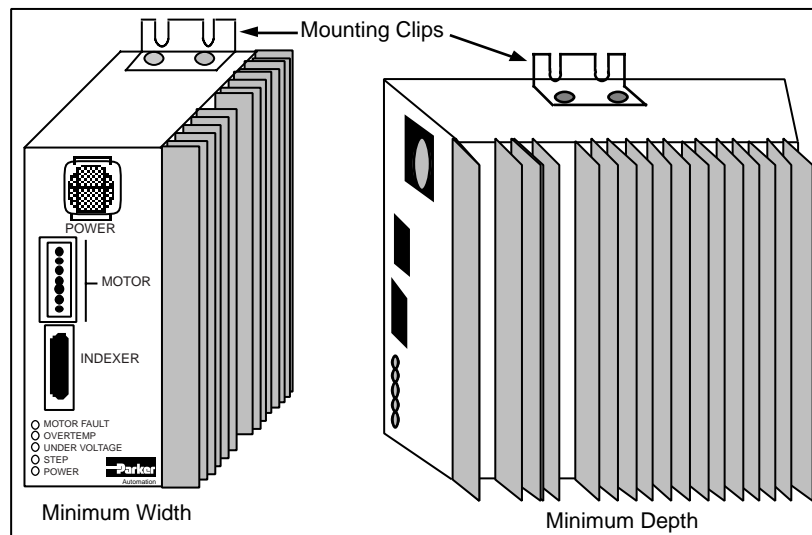

Mounting the Drive

WARNING

If you mount the drive in the minimum depth configuration, the screws (6-32) used to attach the mounting clips to the drive must not be longer than 0.25". Longer screws may damage the internal printed circuit board.

Panel Layout

If you mount the S Drive in an enclosure, observe the following guidelines:

- The vertical and horizontal clearance between the S Drive and other equipment, or the top/bottom of the enclosure, should be no less than 4".
- Do not mount large, heat-producing equipment directly beneath the S Drive.
- Do not mount the S Drive directly below an indexer (the S Drive produces more heat than an indexer).
- Fan cooling may be necessary if air flow is not adequate.

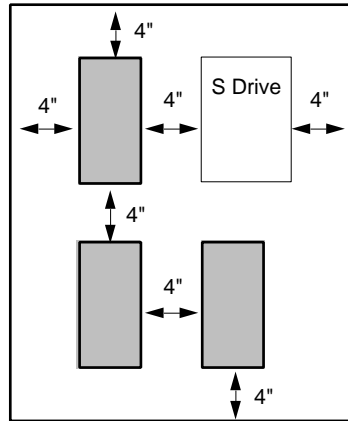

Panel Layout Guidelines

Motor Mounting

Rotary stepper motors should be mounted using flange bolts and positioned with the centering flange on the front face. Foot-mount or cradle configurations are not recommended because the torque of the motor is not evenly distributed around the motor case and they offer poor registration. Any radial load on the motor shaft is multiplied by a much longer lever arm when a foot mount is used rather than a face flange.

WARNING

Improper mounting can compromise system performance and *jeopardize personal safety*.

The motors used with the S Drive can produce very large torques. These motors can also produce high accelerations. This combination can shear shafts and mounting hardware if the mounting is not adequate. High accelerations can produce shocks and vibrations that require much heavier hardware than would be expected for static loads of the same magnitude. The motor, under certain profiles, can produce low-frequency vibrations in the mounting structure. These vibrations can also cause metal fatigue in structural members if harmonic resonances are induced by the move profiles you are using. A mechanical engineer should check the machine design to ensure that the mounting structure is adequate. **Do not attach the load to the motor yet. Coupling the load to the motor is discussed later in this chapter.**

CAUTION

Consult a Compumotor Applications Engineer [800-358-9070] before you machine the motor shaft. Improper shaft machining can destroy the motor's bearings. *Never disassemble the motor (it will cause a significant loss of torque).*

⑨ Attaching the Load

This section discusses the main factors involved when attaching the load to the motor. The following three types of misalignments can exist in any combination.

Parallel Misalignment

The offset of two mating shaft center lines, although the center lines remain parallel to each other.

Angular Misalignment

When two shaft center lines intersect at an angle other than zero degrees.

End Float

A change in the relative distance between the ends of two shafts.

Couplings

The motor and load should be aligned as accurately as possible. Any misalignment may degrade your system's performance.

There are three types of shaft couplings: single-flex, double-flex, and rigid. Like a hinge, a single-flex coupling accepts angular misalignment only. A double-flex coupling accepts both angular and parallel misalignments. Both single-flex and double-flex, depending on their design, may or may not accept end-play. A rigid coupling cannot compensate for any misalignment.

Single-Flex Coupling

When a single-flex coupling is used, one and only one of the shafts must be free to move in the radial direction without constraint. *Do not use a double-flex coupling in this situation—it will allow too much freedom and the shaft will rotate erratically; this will cause large vibrations and immediate failure.*

Double-Flex Coupling

Use a double-flexed coupling whenever two shafts are joined that are fixed in the radial and angular direction (angular misalignment). *Do not use a single-flex coupling with a parallel misalignment; this will bend the shafts, causing excessive bearing loads and premature failure.*

Rigid Coupling

Rigid couplings are generally not recommended. They should be used only if the motor is on some form of floating mounts which allow for alignment compensation.

Helpful Hint: Coupling Manufacturers

HELI-CAL
901 McCoy Lane
P.O. Box 1460
Santa Maria, CA 93456
(805) 928-3851

ROCOM CORP
5957 Engineer Drive
Huntington Beach, CA 92649
(714) 891-9922

For unusual motor installations, call Compumotor for assistance (800-358-9070).

Tuning

This section contains the issues and concerns that you should be aware of as you tune and develop your system.

- Resonance
- Mid-Range Instability

Resonance

Resonance exists in all stepper motors and is a function of the motor's mechanical construction. It can cause the motor to stall at low speeds. Most full-step motor controllers *jump* the motor to a set minimum starting speed that is greater than the resonance region. The S Drive's microstepping capability allows you to run a motor smoothly at low speeds.

*Motors that will not accelerate past 1 rps may be stalling due to resonance. You can add inertia to the motor shaft by putting a drill chuck on the shaft. The drill chuck may provide enough inertia to test the motor when it is **not loaded**. In extreme cases, a viscous damper may also be needed. Refer to Chapter ④ Hardware Reference for your motor's maximum inertia rating.*

The S Drive is factory tuned to minimize resonance problems. If you are running the S Drive at motor resolutions of 200 or 400 steps/rev, you may need an indexer that provides start/stop speed.

Mid-Range Instability

All step motors are subject to mid-range instability, also referred to as parametric oscillations. These oscillations may stall the motor at speeds from 6 to 16 rps.

Tuning Procedures

You can tune the S Drive to minimize resonance and optimize smoothness by adjusting the small potentiometers (pots) on the bottom of the unit. The diagram shows the location of the potentiometers and their functions. A description of each function is listed below.

- Phase A Offset: Adjusts the DC offset of the phase current for Phase A.
- Phase B Offset: Adjust the DC offset of the phase current or Phase B.
- Phase Balance: Adjust the Phase current of Phase B to $\pm 10\%$ of Phase A.

It is not usually necessary to adjust these pots, tuning is done at the factory. Adjustments should be made only if the load inertia is greater than 2-3 times that of the rotor inertia. For best results, the drive and motor should be on, connected to the load, and warmed up for 30 minutes prior to tuning.

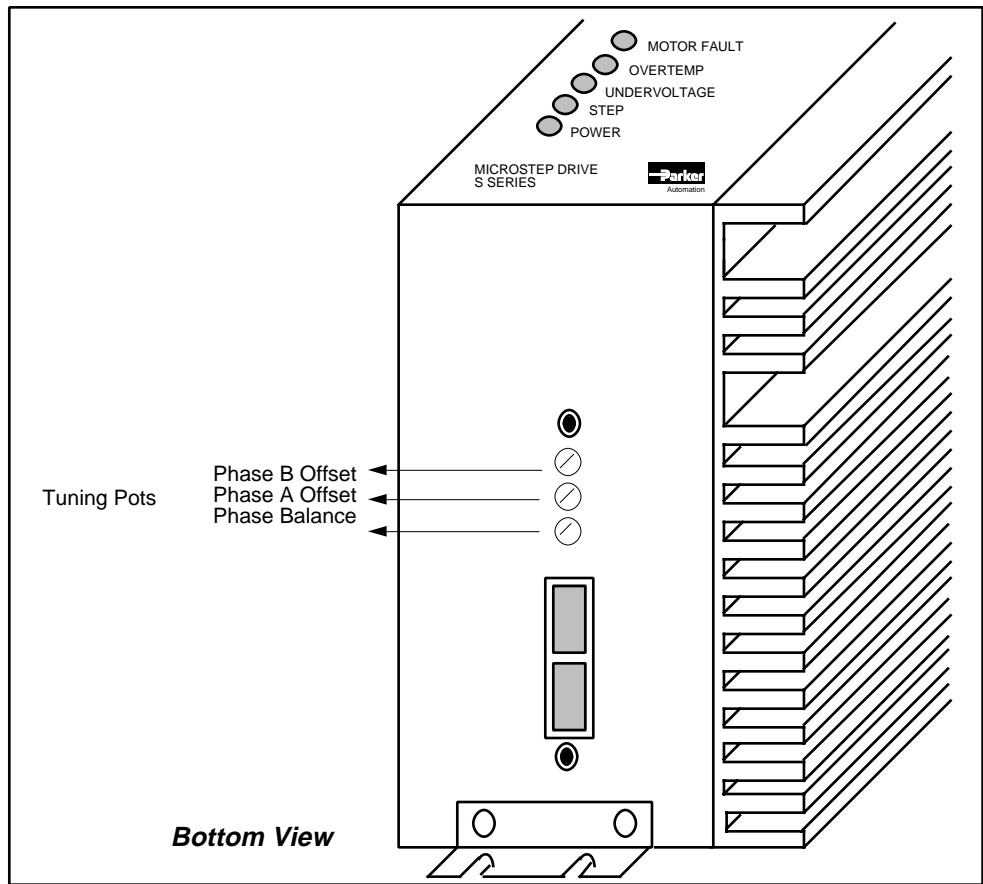

Location of Tuning Pots

Gauging Motor Resonance

There are several methods that you can use to determine the level of motor resonance in your system.

Tachometer Method

Use an oscilloscope to gauge the output of a tachometer attached to the motor shaft. The tachometer will output a DC voltage, proportional to speed. This voltage will oscillate around an average voltage when the motor is resonating. The amplitude of this oscillation will be at its maximum when you run the motor at its *resonance speed*. The goal of this tuning method is to tune the motor for its lowest oscillation amplitude.

Sounding Board Method

You can practice your tuning skills with an unloaded motor placed on a sounding board or table. When you command a velocity that is near the motor's *resonance speed*, the phenomenon will cause an audible vibration. The goal of this tuning method is to tune the motor for the least amount of vibration.

Stethoscope Method

When you tune your motor under loaded conditions, you can hear the audible vibration caused by the motor's natural frequency by placing the tip of a screw driver against the motor casing and placing the handle of the screw driver close to your ear (as you would a stethoscope). You will also be able to hear the different magnitudes of vibration caused by the motor's natural frequency. The goal of this tuning method is to tune the motor for the least amount of vibration.

Touch Method

After you have had some experience with tuning, you should be able to locate the motor's *resonance speed* by placing your fingertips on the motor shaft and adjusting the motor's velocity. Once the *resonance speed* is located, you can tune the motor for maximum smoothness in the same way.

Tuning the Drive to the Motor

Please note that system tuning has been done at the factory. To tune the drive, it is suggested that you first return the potentiometers to their center positions.

- ① Locate the motor's natural resonant frequency.
A table for resonant frequencies for unloaded Compumotor motors is shown below.
By varying the speed lightly from the values given in the table below. Locate the speed of worst resonance.
Adjust the Phase A and Phase B offset potentiometers (located on the bottom of the drive), for best smoothness. Iterative tuning is recommended (adjust Phase A Offset, then B, then A, etc. until no improvement in smoothness is noted).
- ② Decrease the motor's velocity to half the value used in Step ①
Adjust the Phase Balance Potentiometer for best smoothness.

Optional Fine Tuning

- ③ Decrease the motor's velocity by half.
Adjust the Waveform Symmetry DIP switches, located on the bottom of the drive, for best smoothness.
Repeat the above procedure until no further improvement in motor smoothness is noted.

Motor	Phase A & B Offsets (rps)	Phase Balance (rps)	Waveform Adjust (rps)
S57-51	5.15	2.57	1.29
S57-83	3.90	1.96	0.98
S57-102	3.75	1.88	0.94
S83-62	3.00	1.50	0.75
S83-93	2.97	1.48	0.74
S83-135	2.95	1.47	0.74
S106-178	2.11	1.06	0.53
S106-205	2.07	1.04	0.52
S106-250	2.67	1.34	0.67

Motor Waveforms

Step motor manufacturers make every effort to design step motors that work well with sinusoidal current waveforms. However, due to physical limitations, most motors operate best with a current waveform other than a pure sine wave.

The purpose of adjusting motor current waveforms is to set the step motor to move with a step size that is equal to the current waveforms that are sequenced through the motor. This *waveform matching* will also help the motor run more smoothly.

Motor waveforms are usually adjusted after the drive has been tuned to its motor. If you do not have precision measurement equipment, you may select the correct motor waveform with one of the three methods described previously in this chapter (Tachometer Method, Sounding Board Method, Stethoscope Method, and Touch Method). These empirical methods generally yield acceptable results.

Rotary vs. Linear Indexers

Most Compumotor indexers are used for rotary motor systems. Hence, velocities and accelerations are selected in rps and rps² respectively. The default is often 25,000 steps per revolution. For linear motors, velocities and acceleration are usually defined in g's and inches per second (ips) respectively. Use the following equation to convert rps² to g's (1g = 386 ips²).

$$A[g] = \frac{A[\text{rps}^2] \cdot \text{Rotary Resolution} [\text{steps/rev}]}{\text{Linear Resolution} [\text{steps/in}] \cdot 386 \text{ ips}^2}$$

For example, if the rotary resolution is 25,000 steps/rev, the acceleration value is 100 rps², and the linear resolution is 10,000 steps/in. The equation is as follows:

$$\frac{100 [\text{rps}^2] \cdot 25000 [\text{steps/rev}]}{10000 [\text{steps/in}] \cdot 386 \text{ ips}^2} = 0.648 \text{ g}$$

Use the following equation to convert rps to ips:

$$V[\text{ips}] = \frac{V[\text{rps}] \cdot \text{Rotary Resolution} [\text{steps/rev}]}{\text{Linear Resolution} [\text{steps/in}]}$$

For example, if the resolutions are the same as defined above, and the velocity value is 1 rps, the equation would be as follows:

$$\frac{1 [\text{rps}] \cdot 25000 [\text{steps/rev}]}{10000 [\text{steps/in}]} = 2.5 [\text{ips}]$$

☞ Helpful Hint: *Rotary vs Linear Indexer*

Example

- ① Set the unit with the following move parameters:
 - Acceleration = 1000 rps²
 - Velocity = 1 rps
 - Distance = 10,000 steps
- ② Execute the **G** (Go) command:

If the indexer's resolution is 25,000 steps/rev, the forcer should move 1 inch at a velocity of 2.5 ips.

CHAPTER ④

Hardware Reference

The information in this chapter will enable you to:

- Use this chapter as a quick-reference tool for most system specifications (dimensions and performance)
- Use this chapter as a quick-reference tool for DIP switch settings

Environmental Specifications

Drive Temperature

131°F (50°C) measured at the heatsink fins. An internal thermostat will shut down the drive if the unit reaches 158°F (70°C) internally. *Current settings in excess of 4A in high ambient temperature environments (above 113°F [45°C]) may require fan cooling to keep the heatsink temperature within allowable limits and to keep the drive from shutting itself down due to over temperature.*

Motor Temperature

212°F (100°C) maximum allowable motor case temperature. Actual temperature rise is duty cycle dependent.

Electrical Specifications

Input Power

- 90VAC to 132VAC @ 50/60 Hz

Output Power

- Low power: 0.1 to 6A per phase at 170VDC
- High power: 0.2 to 8A per phase at 170VDC

Output Type

- Two phase MOSFET bipolar (H-bridge) switching at 21 kHz (nominal), pulse width modulated

Fault Output

- Open-collector
- Open emitter
- 4N35
- $V_{CE} = 35\text{VDC}$
- $V_{CESAT} = 0.3\text{VDC}$
- Collector Current = 10 mA minimum
- Dissipation = 100 mW maximum

Minimum Motor Winding Inductance

- 2 mH (Compumotor recommends 5 mH measured in series or parallel)

Maximum Motor Winding Inductance

- None (Compumotor recommends 50 mH measured in series or parallel)

Minimum Motor Hipot

- 500VAC

Step & Direction Signal Specification

The inputs are optically isolated and may be driven (activated) by providing a positive pulse to the plus input with respect to the minus input. These inputs may also be differentially driven. The input driver must provide a minimum of 6.5 mA (15 mA maximum).

Step Pulse Input

You must operate the step pulse input within the following guidelines.

- 200 nanosecond-pulse minimum
- 40% - 60% duty cycle (2 MHz max pulse rate)

Direction Input

The direction input may change polarity coincident with the last step pulse. The direction input must be stable for at least 2 ms before the drive receives the first pulse.

Shutdown & Set Zero Phase Signal Specification

The inputs are optically isolated and may be driven (activated) by providing a positive pulse to the plus input with respect to the *minus* input. *The input driver must provide a minimum of 2.5 mA (30 mA maximum). The maximum reverse voltage for this input is 3VDC.*

Shutdown Input (Amplifier Disable)

You may enable this function when the motor is not moving. The input must be active for 100 ms to disable the amplifier. The SHUTDOWN input must be inactive for 100 ms before the first step pulse is received.

Set Zero Phase Input

This input allows you to reset the motor phase currents to power-up position. It is primarily for linear motor applications. The input must be active for 100 ms to reset the motor phase currents to the zero state. The ZERO PHASE input must be inactive for 100 ms before the first step pulse is received.

Fault Output

This output is an open-collector, open emitter output from a 4N35 OPTO isolator. The output transistor will conduct when the drive is functioning properly. The transistor will not conduct when any of the following conditions exist:

- No power is applied to the drive
- There is insufficient AC line voltage (90VAC)
- The drive temperature is too high
- The drive detects a motor fault
- The Shutdown input is enabled

Helpful Hint: Electric Parameters—Outputs

This output has the following characteristics:

- $V_{CE} = 35VDC$
- $V_{CESAT} = 0.3VDC$
- Collector Current = 10 mA minimum
- Dissipation = 100 mW maximum

Operational Specifications

Accuracy

±5 arcminutes typical (unloaded, bidirectional) with Compumotor motors.

Repeatability

±5 arcseconds typical (unloaded, unidirectional).

Hysteresis

Less than 2 arcminutes (0.0334°) unloaded, bidirectional.

Rotor Inertia

Size 23	Rotor Inertia oz-in ²	Rotor Inertia (Kg-m ² x 10 ⁻⁶)
S57-51	0.546	9.998
S57-83	1.1	20.1
S57-102	1.69	30.9
Size 34	Rotor Inertia oz-in ²	Rotor Inertia (Kg-m ² x 10 ⁻⁶)
S83-62	3.47	63.4
S83-93	6.76	124
S83-135	10.47	191
Size 42	Rotor Inertia oz-in ²	Rotor Inertia Kg-cm ²
S106-178	44.0	8.05
S106-205	52.0	9.51
S106-250	63.0	12.14

Rotor Inertia (Compumotor Motors)

Motor Current & Torque

Speed/torque curves for the S Drive are provided later in this chapter.

Motor Size	Current	Static Torque (in-oz)
S57-51 S	1.18	65
S57-51 P	2.28	65
S57-83 S	1.52	100
S57-83 P	3.09	100
S57-102 S	1.71	130
S57-102 P	3.49	130
S83-62 S	2.19	150
S83-62 P	4.42	150
S83-93 S	2.85	290
S83-93 P	5.62	290
S83-135 S	3.47	400
S83-135 P	6.00	343

Motor Specifications (S6)

Motor Size	Current	Static Torque (in-oz)
S106-178 S	6.02	1000
S106-178 P	8.0	667
S106-205 S	3.55	1900
S106-205 P	6.99	1900
S106-250 S	6.02	1450
S106-250 P	8.0	967

S: Series Configuration P: Parallel Configuration

Motor Specifications (S8)

Drive Dimensions

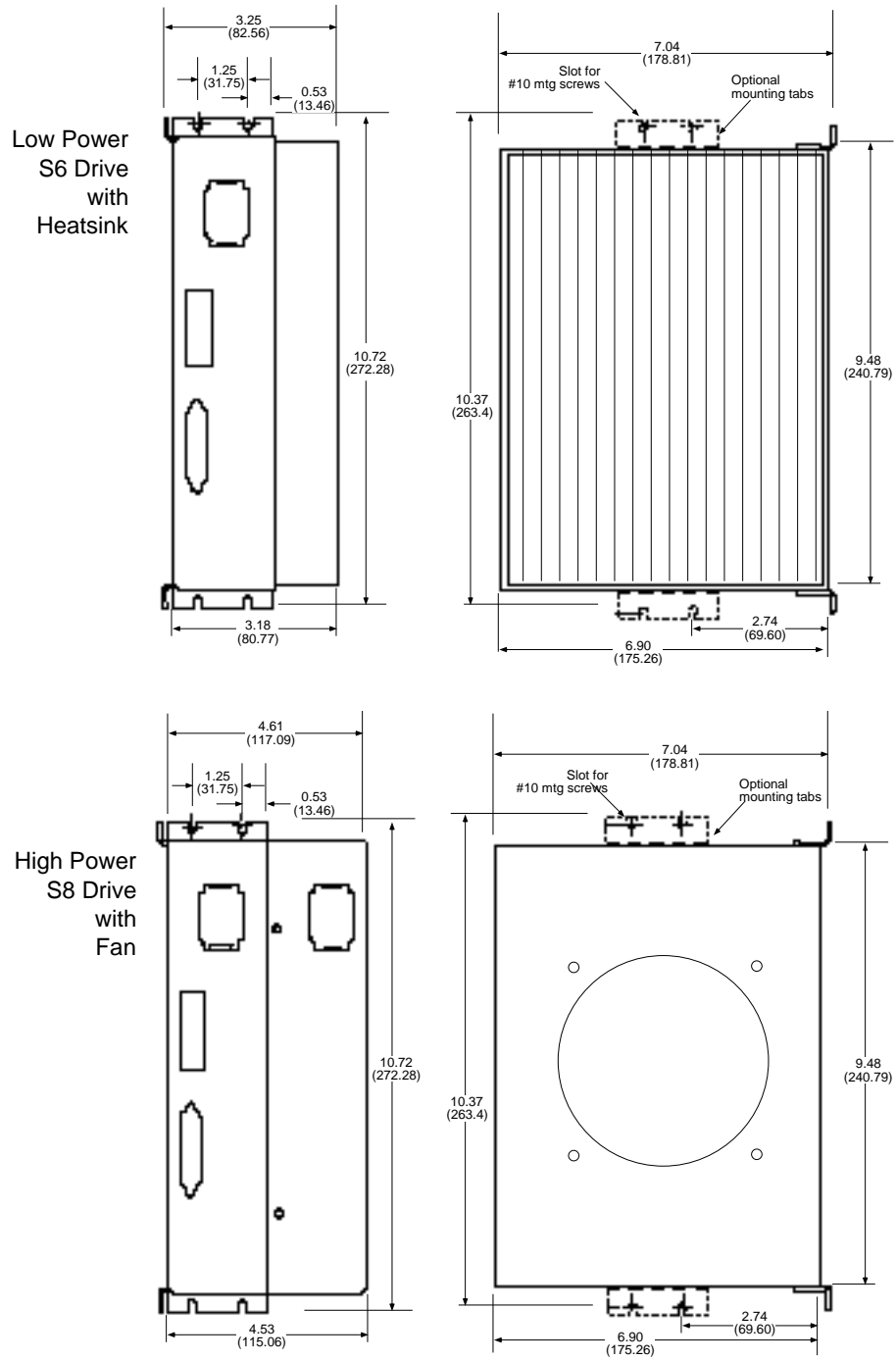

S Drive Dimensions

The fan kit is optional with the low-power version of the S Drive.

Motor Dimensions

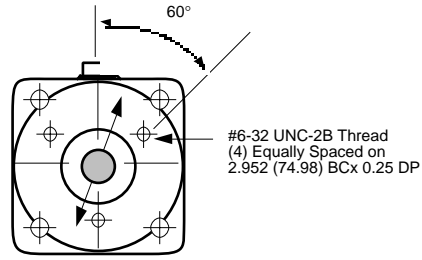
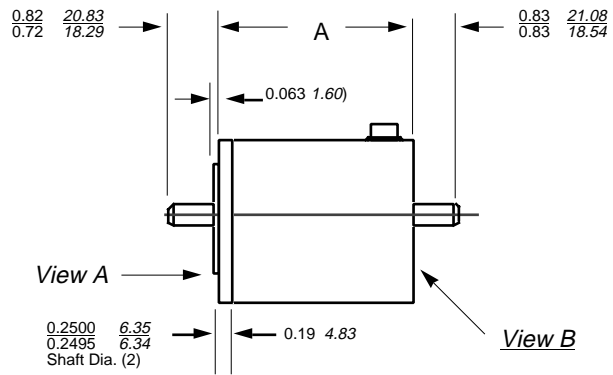
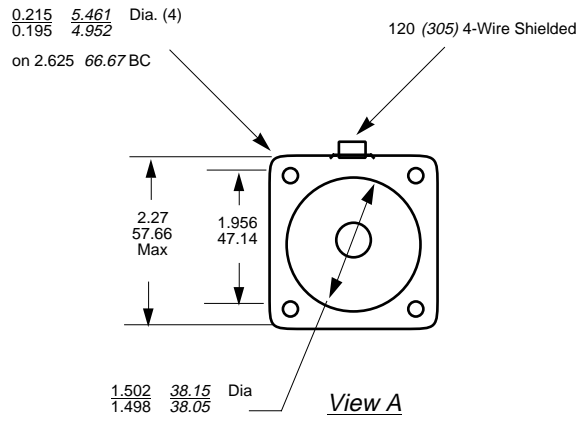

1.118
28.40
Dia.

View B

Size 23 frame

Model	A
S 57-51	2.0 (5.1)
S 57-83	3.1 (7.8)
S 57-102	4.0 (10.2)

NEMA 23 Motor Dimensions

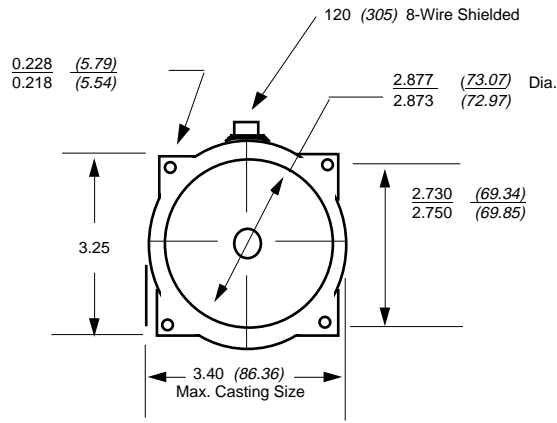

View A

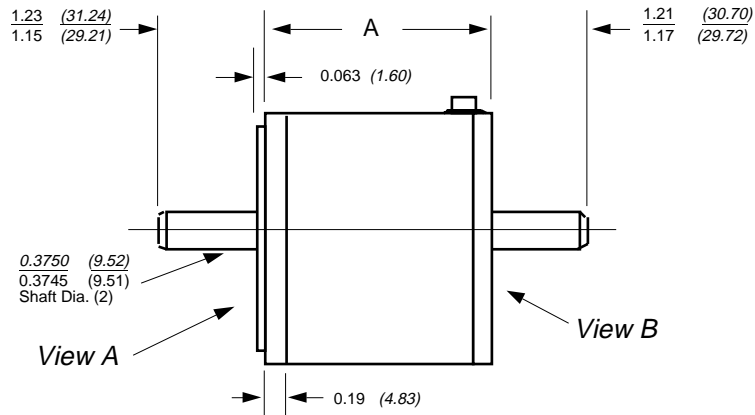

View A

View B

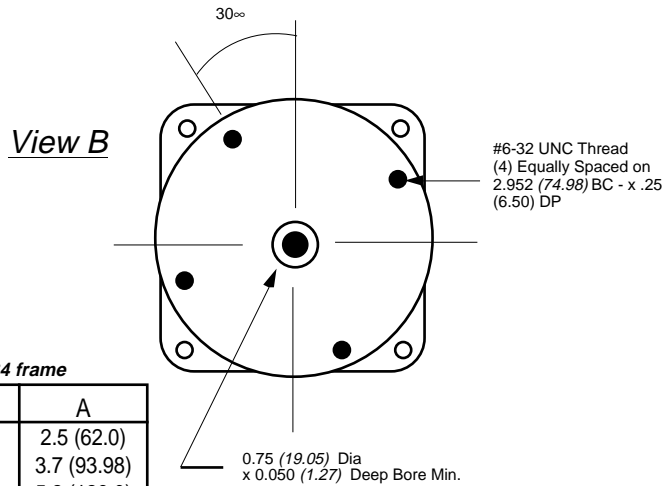

View B

Size 34 frame

Model	A
S 83-62	2.5 (62.0)
S 83-93	3.7 (93.98)
S 83-135	5.2 (129.0)

NEMA 34 Motor Dimensions

S106-178 -- S106-250

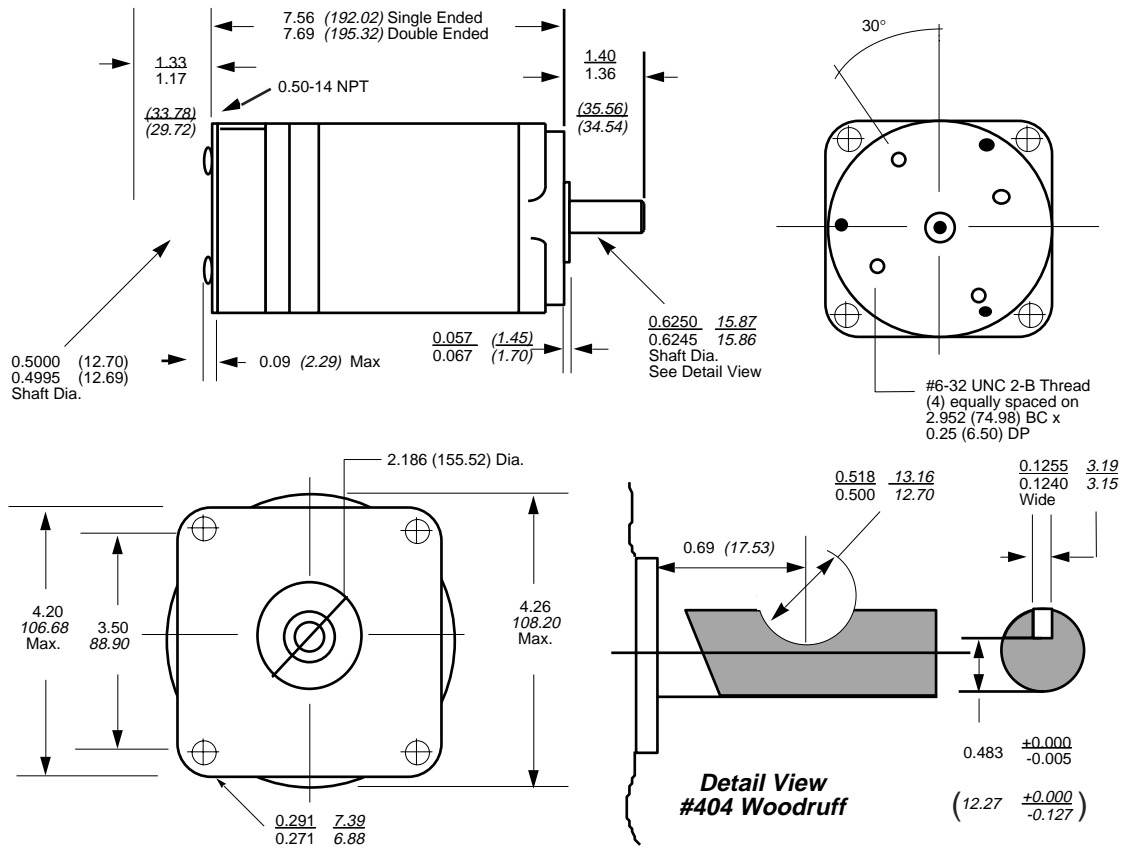

S106-178 Motor Dimensions

S106-205

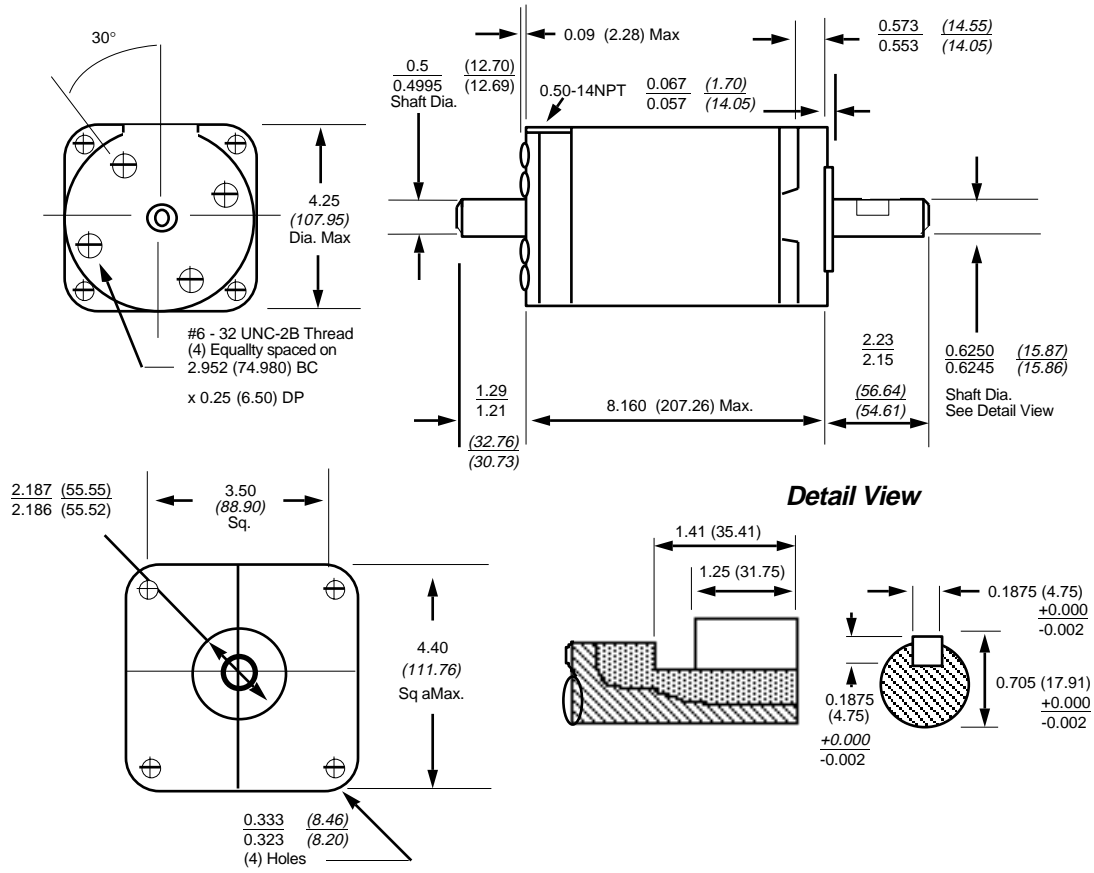

S106-205 Motor Dimensions

DIP Switch Summary

The S Drive has two sets of DIP switches (refer to Chapter ③). Each set of DIP switches has eight individual switches. The first set of switches is referred to as **SW1** and the second set as **SW2**. The individual switch will be preceded by the # symbol. Hence, the third switch on **SW1** is referred to as **sw1-#3**, while the third switch on **SW2** is referred to as **SW2-#3**.

Switch #	Function
sw1-#1	Current—most significant bit
sw1-#2	Current
sw1-#3	Current
sw1-#4	Current
sw1-#5	Current
sw1-#6	Current—least significant bit
sw1-#7	Auto Standby
sw1-#8	Auto Standby
sw2-#1	Motor Resolution
sw2-#2	Motor Resolution
sw2-#3	Motor Resolution
sw2-#4	Motor Resolution
sw2-#5	Waveform
sw2-#6	Waveform
sw2-#7	Waveform
sw2-#8	Auto Test = on, Normal operation = off

DIP Switch Summary

Motor Current

Motor Size	Current	sw1-#1	sw1-#2	sw1-#3	sw1-#4	sw1-#5	sw1-#6
S57-51S	1.18	off	off	on	on	off	off
S57-51P	2.28	off	on	on	off	off	off
S57-83S	1.52	off	on	off	off	off	off
S57-83P	3.09	on	off	off	off	off	off
S57-102S	1.71	off	on	off	off	on	off
S57-102P	3.47	on	off	off	on	off	off
S83-62S	2.19	off	on	off	on	on	on
S83-62P	4.42	on	off	on	on	on	off
S83-93S	2.85	off	on	on	on	on	off
S83-93P	5.62	on	on	on	off	on	on
S83-135S	3.47	on	off	off	on	off	off
S83-135P	6.00	on	on	on	on	on	on

S: Series Configuration **P:** Parallel Configuration

S6 Drive Motor Current (Compumotor Motors)

Motor Size	Current	sw1-#1	sw1-#2	sw1-#3	sw1-#4	sw1-#5	sw1-#6
S106-178S	6.02	on	off	on	on	on	on
S106-178P	8.0	on	on	on	on	on	on
S106-205S	3.55	off	on	on	on	off	off
S106-205P	6.99	on	on	off	on	on	on
S106-250S	6.23	on	on	off	off	off	on
S106-250P	8.0	on	on	on	on	on	on

S: Series Configuration **P:** Parallel Configuration

S8 Drive Motor Current (Compumotor Motors)

Low-Power S6 Drive

Current	SW1	SW2	SW3	SW4	SW5	SW6	Current	SW1	SW2	SW3	SW4	SW5	SW6
0.04	off	off	off	off	off	off	3.09	on	off	off	off	off	off
0.13	off	off	off	off	off	on	3.19	on	off	off	off	off	on
0.23	off	off	off	off	on	off	3.28	on	off	off	off	on	off
0.32	off	off	off	off	on	on	3.38	on	off	off	off	on	on
0.42	off	off	off	on	off	off	3.47	on	off	off	on	off	off
0.51	off	off	off	on	off	on	3.57	on	off	off	on	off	on
0.61	off	off	off	on	on	off	3.66	on	off	off	on	on	off
0.70	off	off	off	on	on	on	3.76	on	off	off	on	on	on
0.80	off	off	on	off	off	off	3.85	on	off	on	off	off	off
0.89	off	off	on	off	off	on	3.95	on	off	on	off	off	on
0.99	off	off	on	off	on	off	4.04	on	off	on	off	on	off
1.08	off	off	on	off	on	on	4.14	on	off	on	off	on	on
1.18	off	off	on	on	off	off	4.23	on	off	on	on	off	off
1.27	off	off	on	on	off	on	4.33	on	off	on	on	off	on
1.37	off	off	on	on	on	off	4.42	on	off	on	on	on	off
1.46	off	off	on	on	on	on	4.51	on	off	on	on	on	on
1.52	off	on	off	off	off	off	4.58	on	on	off	off	off	off
1.62	off	on	off	off	off	on	4.68	on	on	off	off	off	on
1.71	off	on	off	off	on	off	4.77	on	on	off	off	on	off
1.81	off	on	off	off	on	on	4.86	on	on	off	off	on	on
1.90	off	on	off	on	off	off	4.96	on	on	off	on	off	off
2.00	off	on	off	on	off	on	5.05	on	on	off	on	off	on
2.09	off	on	off	on	on	off	5.15	on	on	off	on	on	off
2.19	off	on	off	on	on	on	5.24	on	on	off	on	on	on
2.28	off	on	on	off	off	off	5.34	on	on	on	off	off	off
2.38	off	on	on	off	off	on	5.43	on	on	on	off	off	on
2.47	off	on	on	off	on	off	5.53	on	on	on	off	on	off
2.57	off	on	on	off	on	on	5.62	on	on	on	off	on	on
2.66	off	on	on	on	off	off	5.72	on	on	on	on	off	off
2.76	off	on	on	on	off	on	5.81	on	on	on	on	off	on
2.85	off	on	on	on	on	off	5.91	on	on	on	on	on	off
2.95	off	on	on	on	on	on	6.00	on	on	on	on	on	on

Setting S6 Drive Motor Current (Non-Compumotor Motors)

High-Power S8 Drive

Current	SW1	SW2	SW3	SW4	SW5	SW6	Current	SW1	SW2	SW3	SW4	SW5	SW6
0.05	off	off	off	off	off	off	4.12	on	off	off	off	off	off
0.18	off	off	off	off	off	on	4.25	on	off	off	off	off	on
0.30	off	off	off	off	on	off	4.38	on	off	off	off	on	off
0.43	off	off	off	off	on	on	4.50	on	off	off	off	on	on
0.56	off	off	off	on	off	off	4.63	on	off	off	on	off	off
0.69	off	off	off	on	off	on	4.75	on	off	off	on	off	on
0.81	off	off	off	on	on	off	4.89	on	off	off	on	on	off
0.93	off	off	off	on	on	on	5.01	on	off	off	on	on	on
1.06	off	off	on	off	off	off	5.14	on	off	on	off	off	off
1.19	off	off	on	off	off	on	5.26	on	off	on	off	off	on
1.31	off	off	on	off	on	off	5.39	on	off	on	off	on	off
1.44	off	off	on	off	on	on	5.51	on	off	on	off	on	on
1.59	off	off	on	on	off	off	5.64	on	off	on	on	off	off
1.69	off	off	on	on	off	on	5.77	on	off	on	on	off	on
1.82	off	off	on	on	on	off	5.90	on	off	on	on	on	off
1.94	off	off	on	on	on	on	6.02	on	off	on	on	on	on
2.03	off	on	off	off	off	off	6.11	on	on	off	off	off	off
2.16	off	on	off	off	off	on	6.23	on	on	off	off	off	on
2.28	off	on	off	off	on	off	6.36	on	on	off	off	on	off
2.41	off	on	off	off	on	on	6.48	on	on	off	off	on	on
2.54	off	on	off	on	off	off	6.61	on	on	off	on	off	off
2.66	off	on	off	on	off	on	6.73	on	on	off	on	off	on
2.79	off	on	off	on	on	off	6.87	on	on	off	on	on	off
2.91	off	on	off	on	on	on	6.99	on	on	off	on	on	on
3.04	off	on	on	off	off	off	7.12	on	on	on	off	off	off
3.17	off	on	on	off	off	on	7.24	on	on	on	off	off	on
3.297	off	on	on	off	on	off	7.37	on	on	on	off	on	off
3.42	off	on	on	off	on	on	7.49	on	on	on	off	on	on
3.55	off	on	on	on	off	off	7.62	on	on	on	on	off	off
3.67	off	on	on	on	off	on	7.75	on	on	on	on	off	on
3.80	off	on	on	on	on	off	7.87	on	on	on	on	on	off
3.93	off	on	on	on	on	on	8.00	on	on	on	on	on	on

Setting S8 Drive Motor Current (Non-Compumotor Motors)

Automatic Standby Function

Current	SW1-#7	SW1-#8
* Full Current	off	off
75%	on	off
50%	off	on
25%	on	on

* Default Setting

Automatic Standby Function

Motor Resolutions

Resolution	SW2-#1	SW2-#2	SW2-#3	SW2-#4
50,800 steps	off	off	off	on
50,000 steps	off	off	on	off
36,000 steps	off	off	on	on
25,600 steps	off	on	off	off
25,400 steps	off	on	off	on
* 25,000 steps	off	off	off	off
21,600 steps	off	on	on	off
20,000 steps	off	on	on	on
18,000 steps	on	off	off	off
12,800 steps	on	off	off	on
10,000 steps	on	off	on	off
5,000 steps	on	off	on	on
2,000 steps	on	on	off	off
1,000 steps	on	on	off	on
400 steps	on	on	on	off
200 steps	on	on	on	on

* Default Setting

Motor Resolution Settings

Motor Waveforms

Waveform Shape	SW2-#5	SW2-#6	SW2-#7
Pure Sine	on	on	off
-2% 3rd harmonic	on	off	on
* -4% 3rd harmonic	off	off	off
-4% 3rd harmonic	on	on	on
-4% 3rd harmonic	on	off	off
-6% 3rd harmonic	off	on	on
-8% 3rd harmonic	off	on	off
-10% 3rd harmonic	off	off	on

* Default Setting

Motor Waveform Settings

Automatic Test Function

• SW2-#8 OFF Disables Auto Test
SW2-#8 ON Enables Auto Test

* Default Setting

Motor Performance Specifications

S Series motors are designed to allow you to change the motor winding configuration easily. The following performance indicate that different performance levels can be obtained by connecting the step motor windings in series or parallel. Use caution when you run motors in a parallel configuration. *Sustained operation at high speeds may cause the motor to overheat due to electrical pole heating.*

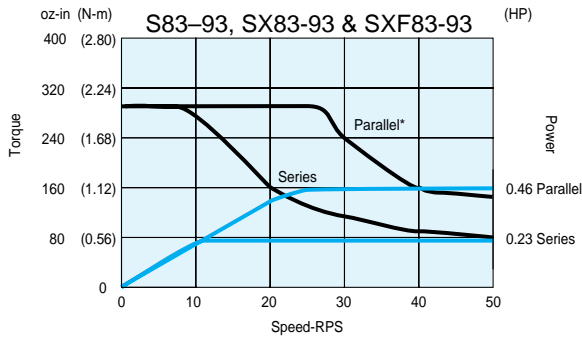
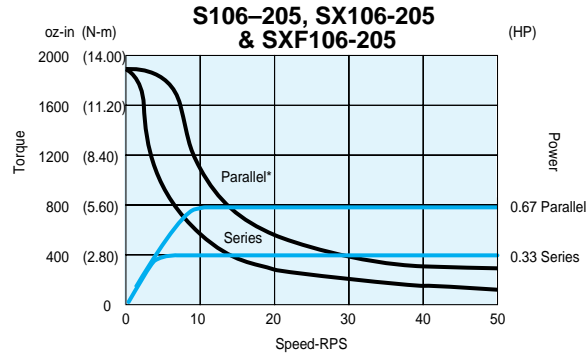
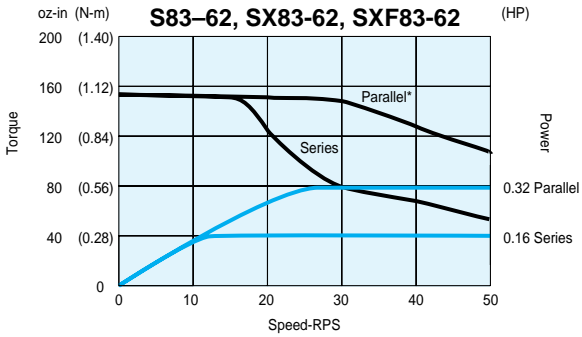
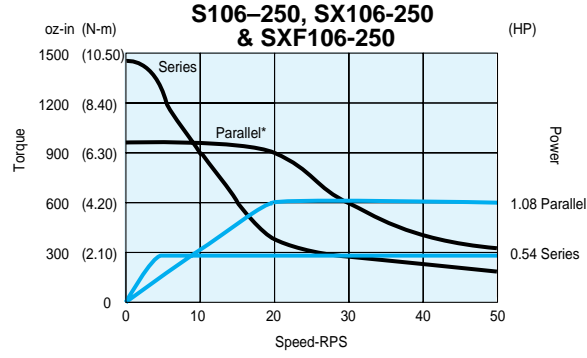
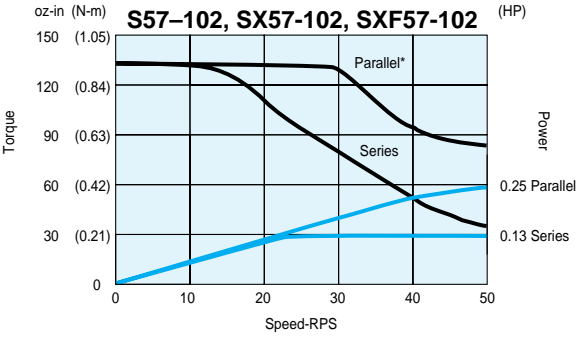
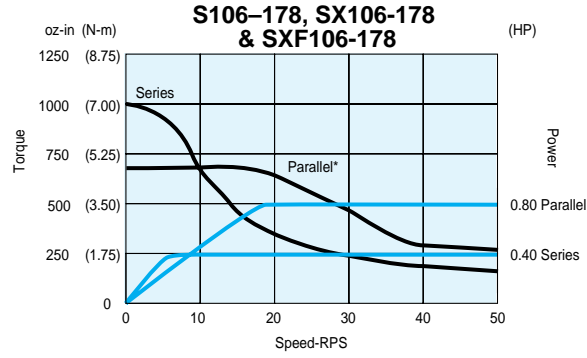
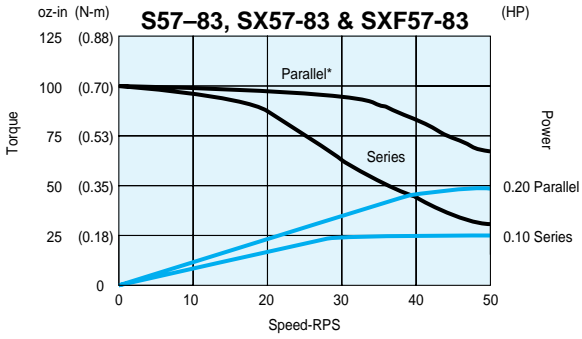
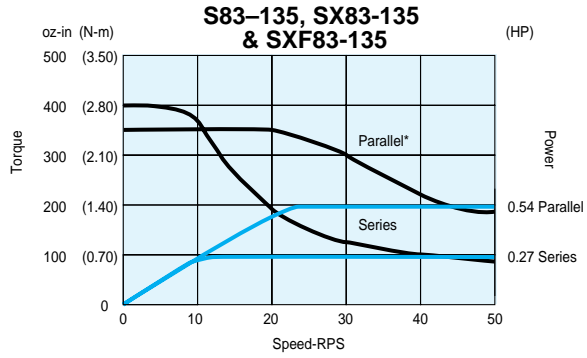
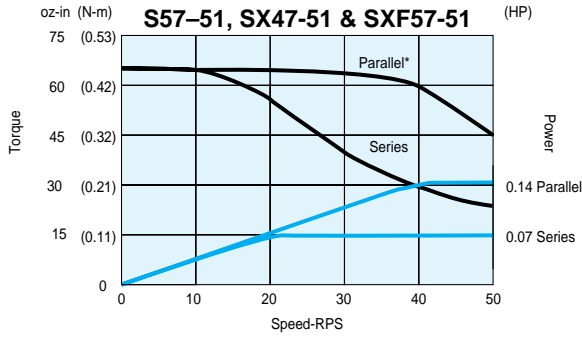

*Parallel connected motors are limited to 50% duty cycle when operated above 5 rps.

For greater than 50% duty cycle above 5 rps, you must connect the motor in series.

Fan cooling the motor will increase duty cycles above 5 rps.

CHAPTER ⑤

Troubleshooting

The information in this chapter will enable you to:

- Maintain the system's components to ensure smooth, efficient operation
- Isolate and resolve system hardware problems

Maintenance

The following items, which are included with the S Drive, can be reordered from Compumotor.

Part	Part Number
9-Pin Phoenix Connector	43-008755-01
7-Pin Phoenix Connector	43-013575-01
AC Power Cord	44-000054-01
Mounting Bracket	53-006007-01

Spare Parts List

Drive Maintenance

Ensure that the drive heatsink is free of particles and has a free flow of air over its entire surface. Enclosures must be connected to earth ground through a grounding electrode conductor to provide a low-impedance path for ground-fault or noise-induced currents. All earth ground connections must be continuous and permanent.

Motor Maintenance

You should inspect all mechanical parts of the motor regularly to ensure that no bolts or couplings have loosened during normal operation. This will prevent minor problems from developing into serious problems.

You should inspect the motor cable periodically for signs of wear. This inspection interval is duty-cycle, environment, and travel-length dependent. The cable should not have excessive tensile force applied to it and should not be bent beyond a one-inch radius of curvature during normal operation. Tighten all cable connectors.

Reducing Electrical Noise

For detailed information on reducing electrical noise in your system, refer to the current Compumotor Catalog.

Problem Isolation

When your system does not function properly (or as you expect it to operate), the first thing that you must do is identify and isolate the problem. When the problem is defined, you can begin to resolve and eradicate the problem.

The first step is to isolate each system component and ensure that each component functions properly when it is run independently. You may have to dismantle your system and put it back together piece by piece to detect the problem. If you have additional units available, you may want to use them to replace existing components in your system to help identify the source of the problem.

Determine if the problem is mechanical, electrical, or software-related. Can you repeat or re-create the problem? Do not make quick rationalizations about the problems. Random events may appear to be related, but they may not be contributing factors to your problem. Carefully investigate and decipher the events that occur before the subsequent system problem.

You may be experiencing more than one problem. You must solve one problem at a time. Document all testing and problem isolation procedures. You may need to review and consult these notes later. This will also prevent you from duplicating your testing efforts.

Once you have isolated the problem, take the necessary steps to resolve it. Refer to the problem solutions contained in this chapter. If your system's problem persists, contact Parker Compumotor at 800-358-9070.

Front Panel LEDs

There are five LEDs on the front panel of the S Drive.

Bottom of S Drive Front Panel

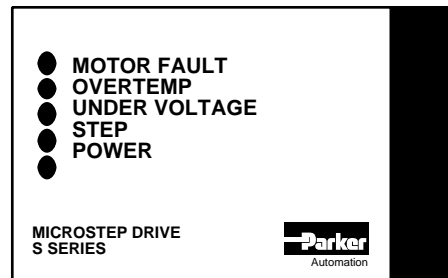

The **MOTOR FAULT** LED is **red** and turns on when the amplifier is disabled. The Fault LED will be activated when any of the following conditions occur:

- Motor short-circuit
- The interlock is broken (opened)
- Shutdown enabled

The **OVERTEMP** LED is **red** and turns on when the internal drive temperature exceeds 70°C.

The **UNDERVOLTAGE** LED is **red** and turns on when AC line voltage is below 85VAC.

The **STEP** LED is **green** and turns on when the drive receives step pulses from an indexer. This LED is a pseudo proportional step indicator. Steps less than 200 Hz may not be visible.

The **POWER** LED is **green** and turns on when the internal bias supply is operating and providing +5V.

Common Problems and Solutions

The table below contains common problems, probable causes, and solutions to the problems. It should help you eradicate most of the problems you might encounter with the S Drive.

Symptoms	Probable Causes	Solutions
The power LED is not on (illuminated).	A. The drive is not receiving AC voltage.	A1. Verify that the connector on the drive is fully seated. A2. Verify that there is AC voltage at the AC outlet that the drive is plugged into. A3. Verify that there is AC voltage at the drive at the AC power connector.
The power LED is flashing.	A. AC Line voltage is too low. B. There is insufficient load regulation on the AC line.	A1. Check AC line voltage (90VAC minimum). B1. Increase the AC line wire size. Increase the isolation transformer size (if used).
There is little or no holding torque. The power LED is on. The motor fault LED is off.	A. The motor current is set too low. B. The motor winding or cable is open. C. The Auto Standby function is enabled. D. Remote shutdown is enabled.	A1. Check the current select switches and verify that the current is set correctly. B1. Check the motor and cable with an ohmmeter. C1. Disable the Auto Standby function if this function does not allow enough holding torque for your application. D1. Disconnect the INDEXER connector to check if the shutdown input is enabled.
The motor fault LED is on.	A. The motor cable is disconnected or not fully seated at the drive. B. The motor connector interlock jumper is missing or is disconnected. C. The drive has detected a motor/wiring short circuit.	A1. Check the motor cable B1. Check the interlock jumper. C1. Check the motor and cable wiring.
The overtemperature LED is on.	A. The internal drive temperature is greater than 70° C.	A. Remove fin cooling obstructions and/or add fan cooling (Compumotor offers a fan kit).
The undervoltage LED is on.	A. The AC line voltage is less than 85VAC.	A. Provide a min. of 90VAC under load to the drive.
The motor moves erratically at low speeds.	A. Motor current is set incorrectly. B. Indexer pulses are being sent to the drive erratically. C. Motor resolution is set for 200 or 400 steps per revolution.	A1. Check the current select switches and verify that the current is set correctly. B1. Verify, with an oscilloscope, that the indexer pulses are being sent at a constant rate and are not being frequency modulated. C1. Full and half step modes will cause the motor to run roughly at low speeds.
The drive loses pulses at high speed.	A. The indexer is overdriving the step input. B. The indexer is underdriving the step input. C. The indexer is sending pulses too fast. D. The motor is out of torque.	A1. Verify that the step input current is not greater than 15 mA. B1. Verify that the step input current is ≥ 6.25 mA. C1. Verify that the indexer is not exceeding the 2 MHz maximum pulse rate. D1. Verify that the motor is sized correctly for your application.
The motor stalls at high speeds.	A. The velocity is too high. B. Motor current is not set correctly. C. The motor is undersized for the application.	A1. The drive can handle a max. pulse rate of 2 MHz or 50 rps, whichever comes first. Decrease the velocity. B1. Check the current DIP switches and verify that the current is set correctly. C1. Verify that the motor is sized correctly.
The motor stalls during acceleration.	A. Motor current is not set correctly. B. The acceleration is set too high. C. There is insufficient rotor inertia. D. The motor is undersized for the application.	A1. Check the current select switches and verify that the current is set correctly. B1. Decrease the acceleration. C1. Add inertia to the motor shaft. D1. Verify that the motor is sized correctly for your application
The motor (unloaded) stalls at nominal speed.	A. There is insufficient rotor inertia.	A1. Add inertia to the motor shaft.
The motor does not move the commanded distance.	A. The motor resolution is set incorrectly.	A1. Determine the resolution on your indexer and verify that the drive resolution is the same.
The motor will not change direction as commanded.	A. The direction input is not being enabled.	A1. Verify that the direction input is being enabled (6.4 mA to 15 mA).
The indexer moves the motor in the wrong direction.	A. There is a direction conflict within the indexer.	A1. Change the direction sense within your indexer. A2. Change the motor direction by swapping motor leads A+ and A- at the drive connector.

Testing the Motor

If the motor fails to move, you should test the motor with an ohmmeter to examine the resistance between the motor connections. If the motor is not malfunctioning, the source of the problem is probably within the drive. If you operate a faulty drive with a reliable motor, you may damage the motor. If you find that the motor is not faulty, remove power, and remove the motor from the drive. Use the following steps to test the motor.

1. Remove power from the system. Detach the motor from the drive.
2. With the motor detached from the system, use an ohmmeter to check the resistance across Phase A. **It should be approximately 2 ohms.**
3. Now use the ohmmeter to check the resistance across Phase B. It should be approximately 2 ohms too (the resistance across Phase A and Phase B should be nearly identical).
4. Use the ohmmeter to check the resistance between Phase A and Phase B. It should be infinite (∞).
5. Use the ohmmeter to check the resistance between Phase A and Earth (the motor case shaft). It should be infinite (∞).
6. Use the ohmmeter to check the resistance between Phase B and Earth (the motor case shaft). It should be infinite (∞).
7. Turn the shaft manually. There should not be any torque.

If the motor responds as described to each of these steps, it is functioning properly. The source of the problem is probably within the drive.

Returning the System

If your S Drive system is faulty, return the drive and motor for replacement or repair. A failed drive can damage motors. If you return your S Drive to effect repairs or upgrades, use the following steps:

- ① Get the serial number and the model number of the defective unit(s), and a purchase order number to cover repair costs in the event the unit is determined by Parker Compumotor to be out of warranty.
- ② Before you ship the drive to Parker Compumotor, have someone from your organization with a technical understanding of the S Drive and its application include answers to the following questions:
 - What is the extent of the failure/reason for return?
 - How long did it operate?
 - How many units are still working?
 - How many units failed?
 - What was happening when the unit failed (i.e., installing the unit, cycling power, starting other equipment, etc.)?
 - How was the product configured (in detail)?
 - What, if any, cables were modified and how?
 - With what equipment is the unit interfaced?
 - What was the application?
 - What was the system sizing (speed, acceleration, duty cycle, inertia, torque, friction, etc.)?
 - What was the system environment (temperature, enclosure, spacing, unit orientation, contaminants, etc.)?
 - What upgrades, if any, are required (hardware, software, User Guide)?
- ③ Call Parker Compumotor's Applications Engineering Department [(800) 358-9070] for a Return Material Authorization (RMA) number. Returned products cannot be accepted without an RMA number.
- ④ Ship the unit to:
Parker Compumotor Corporation
5500 Business Park Drive
Rohnert Park, CA 94928
Attn: RMA # xxxxxxx

A P P E N D I X

LVD Installation Instructions

Complying with the Low Voltage Directive (LVD)

The S Drive, when installed according to the procedures in the main body of this user guide, may not necessarily comply with the Low Voltage Directive (LVD) of the European Economic Community. To install the S Drive so that it complies with LVD, you must follow the additional procedures described in this appendix. If this is not done, the protection of the product may be impaired.

For more information about LVD, see 73/23/EEC and 93/68/EEC, published by the European Economic Community (EEC).

Additional Installation Procedures for LVD Compliance

Environmental Conditions

Pollution Degree

The S Drive is designed for pollution degree 2.

Installation Category

The S Drive is designed for installation category II.

Electrical

Connecting and Disconnecting Power Mains

The S Drive's protective earth connection is provided through its make first/break last earth terminal on the power mains connector. You must reliably earth the S Drive's protective earth connection. Attach or remove the S Drive's power plug only while input power is OFF.

Using an Isolation Transformer

The S Drive's mains voltage is limited to 120 VAC nominal, single phase. If your mains voltage is higher, use an isolation transformer located between the power mains and the S Drive. Your isolation transformer should be insulated to ~2300V rms.

CAUTION

Do not use an autotransformer.

Line Fuses

Line fuses need to be added to protect the transformer and associated wiring. If the live wire cannot be readily identified, fuse both phase conductors. The value of fuse required is given by:

$$(1.5 \times VA)/(\text{supply volts}) \quad [\text{amps}]$$

Fuse types should be anti-surge HBC.

Providing a Protective Earth Connection for Motors

You must provide a connection from the motor to a reliable protective earth. This connection provides a protective earth for the motor contact point. The motor's protective earth connection is important for safety reasons, and **must not be omitted**.

Make connections according to the following instructions and diagram:

- ① Use a spade lug in combination with a star washer and mounting bolt to make good contact with the bare metal surface of the motor's mounting flange.
- ② Use a green and yellow striped wire to make the connection between the motor and earth. Wire gauge must be no thinner than the current-carrying wire in the motor's power cable.
- ③ Resistance between the motor and earth must be no greater than 0.1 Ω. Use thicker gauge wire if the resistance is too high.

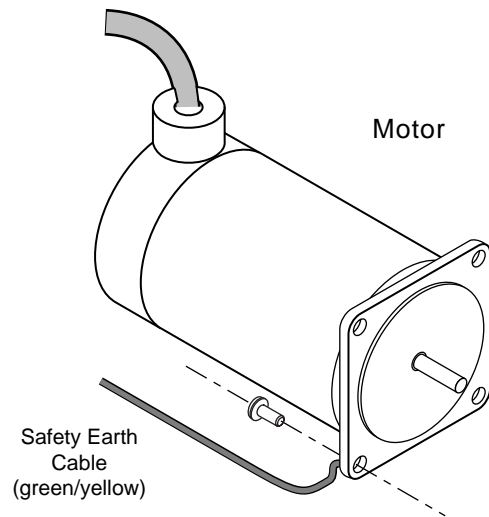

Providing Protective Earth Connection for Motor

Mechanical

Installing in an Enclosure

The S Drive must be installed within an enclosure. The enclosure's interior must not be accessible to the machine operator. The enclosure should be opened only by skilled or trained service personnel.

Servicing the S Drive

Changing Firmware

Only skilled or trained personnel should change firmware.

Do Not Replace Fuses

The S Drive has no fuses designed to be replaced by the user. Fuse failure indicates that other components have also failed. Fuses and other components should only be replaced by Cumputor or its designated repair facilities.

Thermal Safety

The S Drive May Be Hot

The S Drive may reach high temperatures during normal operations, and may remain hot after power is removed.

The Motor May Be Hot

The motor may reach high temperatures during normal operations, and may remain hot after power is removed.







Sonic Pressure

High Sound Level

The sound level from some large frame step motors (NEMA 34, NEMA 42, and larger) may exceed 85 dBA. Actual sound level is application dependent, and varies with motor loads and mounting conditions. Measure the sound level in your application; if it exceeds 85 dBA, install the motor in an enclosure to provide sound baffling, or provide ear protection for personnel.

Table of Graphic Symbols and Warnings

The following symbols may appear in this User Guide, and may be affixed to the products discussed in this User Guide.

Symbol	Description
	Earth Terminal
	Protective Conductor Terminal
	Frame or Chassis Terminal
	Equipotentiality
	Caution, Risk of Electric Shock
	Caution, Refer to Accompanying Text
	Hot Surface

INDEX

Symbols

9-pin motor
Color code 17

A

AC Power Connection 27
AC power connection
Molded power cable 27
Amps
Current ratings 29
Applications Engineering Department
54
Assumptions vii
Automatic standby function 49
Automatic test function 5, 49

B

Best performance 1
Bipolar
Current 22
Output type 39

C

Cabinet loss 29
CE 55
CE Mark ii
Product Type ii
Color code 13
Series and Parallel 14, 15, 16
Color codes
9-pin motor 17
Common problems and solutions 53
Compumotor
Applications Engineering 32
Motors
9-pin version 17
S106-205 15
S106-250 16

Contents of this manual vii
Core losses 29
Coupling manufacturers 33
Couplings 33
Shaft couplings 33
Current
Bipolar 22
Current (Amps)
Current rating 29

D

Developing Your Application viii
DIP switch
Summary 47
DIP switch settings
Automatic Standby 24
Automatic Test 5, 25
Drive configuration 24
Motor current 18
Motor current settings 18
Motor resolution settings 24
Motor waveforms 25
Quick-reference tool 39
DIP switches 4, 11
Location 4
Modification 11
S6 Motor Current 5
S8 Motor Current 5
SW1 4, 11
SW1-#3 4, 11
SW2 4, 11
SW2-#3 4, 11
Direction input 40
Double-Flex Coupling 33
Drive configuration 24
Drive label 3
Drive maintenance 51
Drive temperature 39
Drive/Indexer Connection 26

E

Electrical noise 10
Electrical specifications 39
Input power 39
Output power 39
Environmental considerations 9
Environmental specifications 39
Extended Motor Cables 18

F

Failed drive 54
Returning the system 54
Fan connection 27
Fan kit 27
Fault input 40
Fault output 27, 39
Schematic 26
Features 1
Filter 10
Fine tuning 36
Front panel LEDs 52

G

Gauging motor resonance 35
Getting started 3
Grounding 10
Motor casing 10
Requirements 10
Temporary installation 10

H

Hardware reference 39
Heatsink temperature 9
High-power 48
How to use this User Guide i, vii
Hyperbola 30

I

- Indexers 37
 - Equations 37
 - Linear resolution 37
 - Rotary resolution 37
- Input
 - Direction input 40
 - Fault input 40
 - Set Zero Phase Input 40
 - Shutdown & Set Zero Phase Signal
 - Specification 40
 - Shutdown input 40
 - Step pulse input 40
- Input power 39
- Inputs 26
 - Direction input 26
 - Schematic 26
 - Shutdown Input 26
 - Step & Direction Signal
 - Specification 40
 - Step pulse input 26
- Installation 9
 - Precautions 9
- Installation overview 12
- Installation Preparation viii
- Installation Process Overview viii
- Internal thermostat 9
- Introduction 1
 - Features
 - Product description 1
- Isolation transformer 28

L

- LEDs 52
 - Motor Fault LED 52
 - Overtemp LED 52
 - Power LED 52
 - Step LED 52
 - Undervoltage LED 52
- Load 33
- Low-power 48
- LVD
 - Electrical 55
 - Environmental conditions 55
 - Graphics table 57
 - Installation instructions ii, 55
 - Line fuses 56
 - Mechanical 56
 - Protective earth connection 56
 - Servicing the S Drive 56
 - Sonic pressure 57
 - Thermal safety 57
- LVD Compliance 55

M

- Maintenance 51
- Malfunctioning
 - Testing the motor 54
- Maximum motor wiring inductance 40
- Mid-range instability 34
- Minimum motor wiring inductance 39
- Misalignments 33
- Molded power cable 27
- Motor
 - Performance specifications
 - Motor windings 49
 - Resolutions 24, 49
 - Motor configuration 13
 - Motor current 4, 47
 - DIP switch table 4
 - S6 drive motor 18
 - S8 drive motor 18
 - Motor heating 13
 - Motor maintenance 51
 - Motor mounting 32
 - Flange bolts 32
 - Motor performance specifications 49
 - Motor temperature 39
 - Motor type 29
 - Motor waveforms 36, 49
- Motors
 - Motor cables 18, 22
 - NEMA 23 Motor Dimensions 43
 - NEMA 34 Motor Dimensions 45
 - S106-205 Motor Dimensions 46
- Mounting 31
 - Clearance 32
 - Minimum depth 31
 - Minimum width 31
- Mounting clips
 - Screws 31

N

- Non-Compumotor motor
 - Caution 19
 - Pre-wired motor cable 5
- Non-Compumotor motors 5
 - Bipolar current 22
 - Motor current
 - High-power S8 Drive 23
 - Low-power S6 Drive 23
 - Precautions and instructions 5
 - Recommended motor cables 22
 - Requirements 19
 - Setting motor current 22
 - Terminal connections 21
 - Unipolar current 22
 - Wiring configurations 19
 - 4-Lead Motor 19
 - 6-Lead Motor 19
 - 8-Lead Motor 20

O

- Ohmmeter 19
- Operational specifications
 - Accuracy 41
 - Repeatability 41
- Operational specificationsSpeci 41
- Output power 39

P

- Panel layout
 - Guidelines 32
- Parallel configuration 20
- Parametric oscillations 34
- Peak Motor Loss 29
- Peak Shaft Power 30
- Peak Total Power 30
- Phase A Offset 34
- Phase B Offset 34
- Phase balance 34
- Power cable 6
- Pre-wired motor cable 5
- Precautions 9
- Product description 1

Q

- Quick Test 3
 - DIP switches 4
 - Indexer 6

R

- Related Publications viii
- Repair 54
- Resonance 34
- Resonance speed 35
 - Method 35
- Return Material Authorization (RMA) 54
- Rigid Coupling 33

S

- S Drive 3, 18
 - Damage report 3
 - DIP switch summary 47
 - high-power 3, 18
 - Limited voltage 27
 - low-power 3, 18
 - Microstepping capability 34
 - Power ratings 28
- S6 Drive
 - Fan kit 29
 - Low-power 48
 - Motor current setting 48
- S8 Drive
 - High-power 48
- Series configuration 20
- Series vs. Parallel Wiring 13
- Set Zero Phase Input 27, 40
- Shaft couplings 33
- Ship kit 3
- Shutdown & Set Zero Phase Signal
 - Specification 26, 40
- Shutdown input 7, 30, 40
- Single-Flex Coupling 33
- Spare parts list 51
- Step & Direction Signal Specification
 - 26, 40
- Step pulse input 40
- Step pulses 7, 30
 - Shutdown input 30

T

- Testing the motor 54
 - Malfunctioning 54
- Thermal dissipation 29
- Thermal interface 10
- Transformer specifications 28
 - Table 28
- Troubleshooting 51
 - Maintenance 51
- Tuning 34
 - Potentiometers 34
 - Tuning procedures 34
- Tuning Procedures 34

U

- User Guide Change Summary i

V

- Volt-Amp
 - Rating 30

W

- Warning 12
- Waveform
 - Correct motor waveforms 36
- Waveform Symmetry DIP switches
 - 36
- Winding inductance 39
- Wiring considerations 9
 - Guidelines 9
- Wiring diagram 12

