

# CHAPTER ③

---

## Installation

The information in this chapter will enable you to:

- Ensure that the complete system is installed correctly
- Mount all system components properly

Before proceeding with this chapter, you should have completed the steps and procedures in *Chapter ② Getting Started*.

## Installation Precautions

---

This section contains precautions that you must follow to configure and operate your S Drive system properly.

### Environmental Considerations

An internal thermostat will shut down the drive if it reaches 158°F (70°C) internally. Current settings in excess of 4A in high ambient temperature environments (above 113°F [45°C]) may require fan cooling to keep the heatsink temperature within allowable limits and to keep the drive from shutting itself down due to overtemperature. *The maximum allowable motor case temperature is 212°F (100°C). Actual temperature rise is duty cycle dependent.*

---

**CAUTION**

When connected in parallel, S Drive motors can overheat if operated at high speeds for extended periods of time.

---

### Wiring Considerations

There are hazardous voltages present on the S Drive's connectors when power is applied. To prevent injuries to personnel and damage to equipment, note the following guidelines:

- Never connect/disconnect the motor from the drive when power is applied. If you do, the motor connector may be damaged. Power should never be applied to the drive when the motor is not connected.
- Never increase the current setting (using the drive's DIP switches) to more than 10% greater than the current specified for the motor you are using. Excessive current may cause the motor to overheat and result in a motor failure.
- Verify that there are no wire *whiskers* that can short out the motor connections. If the motor turns the wrong direction after you connect the motor wires to the connector and the connector to the drive, you can change the direction by reversing the leads going to **A+** and **A-** on the motor terminal.

- Never extend the **INLNK** jumper beyond the connector. This jumper protects the motor connector and should **not** be used as a system interlock.
- **Never** probe the drive. **Never** connect anything other than the motor to the motor terminals. Probing or opening the drive in any other way will void the warranty. Hazardous voltages are present within the drive. **The thermal interface will be broken if you open the drive. The thermal interface is critical to the reliability of the drive.**

## Grounding

Proper grounding of electrical equipment is essential to ensure safety. You can reduce the effects of electrical noise due to electromagnetic interference (EMI) by grounding. All Compumotor equipment should be properly grounded. Refer to the National Electrical Code published by the National Fire Protection Association of Boston, MA for more information on grounding requirements.

In general, all components and enclosures must be connected to earth ground through a grounding electrode conductor to provide a low-impedance path for ground fault or noise-induced currents. All earth ground connections must be continuous and permanent. Compumotor recommends a single-point grounding setup. Prepare components and mounting surfaces prior to installation so that good electrical contact is made between mounting surfaces of equipment and enclosure. Remove the paint from equipment surfaces where the ground contact will be bolted to a panel and use star washers to ensure solid, bare metal contact.

For temporary installation, or when you cannot implement the grounding method described above, connect the GND terminal on the AC power connector to earth ground. Whenever possible, route high-power signals (i.e., motor and power) away from logic signals (i.e., step and direction, RS-232C, RS-422/485, parallel output) to prevent electrical noise problems.

## Preventing Electrical Noise Problems

The S Drive provides power to the motor by switching 170VDC (120VAC input) at 21 KHz (nominal). This has the potential to radiate or conduct electrical noise along the motor cable, through the motor, and into the frame to which the motor is attached. It can also be conducted out of the drive into the AC power line. Use the following steps to prevent problems caused by electrical noise generated by the S Drive:

- ① Ground the motor casing (*already done for you with Compumotor motors*).

---



---

### **WARNING**

You must ground the motor casing. Motor winding case capacitance can cause large potentials to develop at the motor. This can create a lethal shock hazard.

---



---

- ② Avoid extended motor cable runs. Mount the drive as close as is practical to the motor.
- ③ Mount equipment that is sensitive to electrical noise as far as possible from the S Drive and motor.
- ④ Filter power to the S Drive with a PI type filter and an isolation transformer (refer to the power ratings later in this chapter). The filter reduces the AC line noise that the S Drive generates back into the AC line. The Corcom® EP Series filter works well with the S Drive.  
Corcom  
1600 Winchester Road  
Libertyville, IL 60048 Telephone: (847) 680-7400
- ⑤ Provide a separate power line for the S Drive. Do not use the same power circuit for equipment that is sensitive to electrical noise and the S Drive.
- ⑥ Shield the motor cable in conduit and ensure the conduit is taken to a low impedance earth ground.

## DIP Switches

The S Drive has two sets of DIP switches (refer to the figure below). Each set of DIP switches has eight individual switches. The first set of switches is referred to as **SW1** and the second set as **SW2**. The individual switch will be preceded by the # symbol. Hence, the third switch on **SW1** is referred to as **SW1-#3**, while the third switch on **SW2** is referred to as **SW2-#3**.

To modify any of the drive's switch settings, **remove power from the drive** and follow the steps below.

- ① Remove the panel that covers the DIP switches.
- ② Make the required adjustments.
- ③ Screw the panel back into place over the switches.

The S Drive recognizes changes to its switch settings during power up only.

---

### WARNING

**Never** adjust switches with power applied to the unit.  
Hazardous voltages are contained within the drive when power is applied.

---

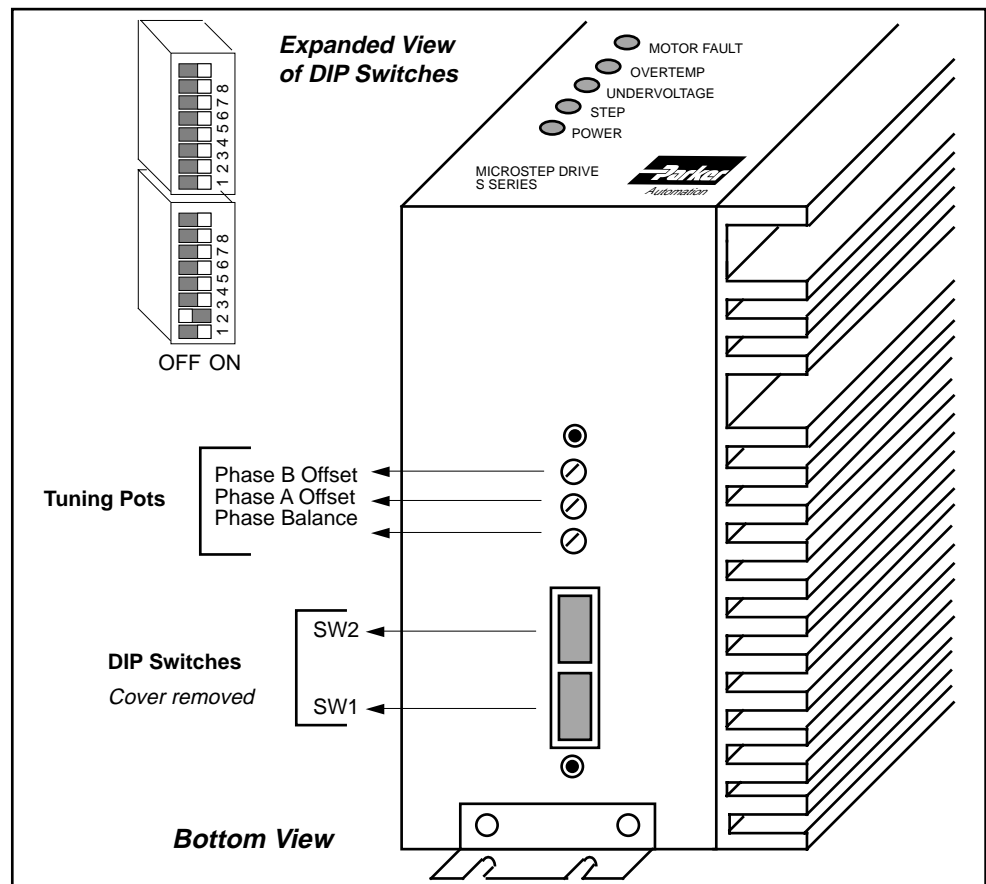

DIP Switch & Tuning Pot Locations

# Installation Overview

The procedures in this chapter will enable you to configure and wire your system. The following graphic shows the front panel of the S Drive. The following installation steps will be discussed:

- ① Series vs. Parallel Motor Wiring
- ② Motor/S Drive Configuration (Wiring & Motor Current)
  - Compumotor Motors
  - Non-Compumotor Motors
- ③ Set Other DIP Switches
- ④ Wire Indexer to S Drive
- ⑤ Fan connection (*for S6 —fan is standard for S8*)
- ⑥ Apply Power to S Drive
- ⑦ Test the System
- ⑧ Mount the S Drive and the motor
- ⑨ Attach the Load

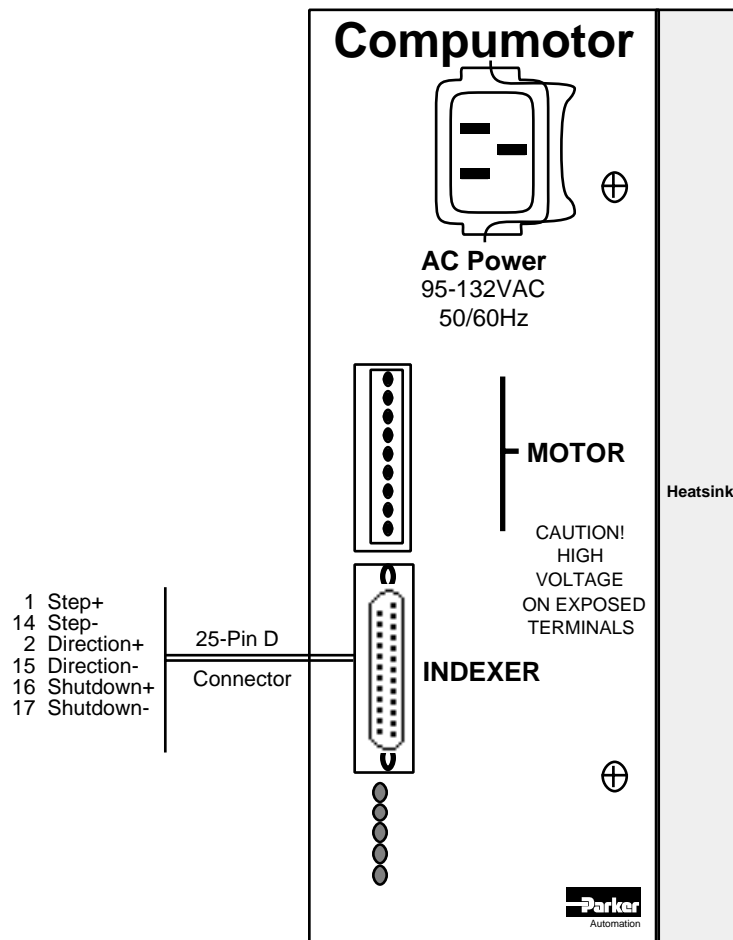

S Drive Wiring Diagram (S6 Drive Shown)

**Do not deviate from the steps in this chapter. Do not wire or apply power to the system until you are instructed to do so. If you do not follow these steps, you may damage your system.**

## ① Series vs. Parallel Motor Wiring

S Series motors are shipped from the factory wired in series. You may re-wire the motor (shown later in this chapter—*Wiring Configurations*). Parallel configurations provide more torque than series configurations provide at high speeds (refer to the speed/torque curves in *Chapter ④ Hardware Reference*). You must observe certain precautionary measures to prevent overheating when using motors wired in parallel configurations (refer to *Non-Compumotor—Drive/Motor Connection* later in this chapter).

### Motor Heating

S Series motors that are wired in series can be run continuously at speeds that incur peak motor loss. S Series motors that are wired in parallel, however, cannot be run at peak motor loss levels continuously without overheating (unless extensive cooling measures are employed). Most applications do not require continuous slewing at high speed. Therefore, the average motor loss will be within safe limits.

## ② Motor Configuration

The S Drive can run Compumotor and Non-Compumotor motors. This section provides instructions for configuring Compumotor and Non-Compumotor motors. **Follow only the directions that apply to the type of motor that you are using.**

### Compumotor Motors—Drive/Motor Connection

Compumotor motors are pre-wired in series and require no setup other than being plugged into the drive. If you plan to run the motor in series, no further motor wiring setup is required.

***Your S Drive's motor connector may be a 7-pin or 9-pin connector. Follow the instructions that apply to your connector only.***

*Frame size 23 and 34 motors (S57 or S83) are 8 lead motors. Frame size 42 (S106) are 4 lead motors. The graphic below represents the motor winding color code for 8 lead, 23 and 34 frame size motors.*

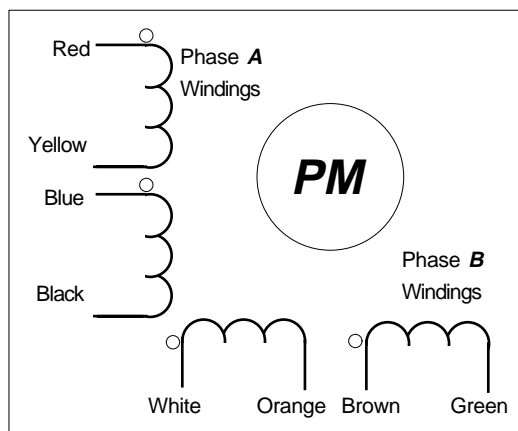

*8-Lead Motor Winding Color Code*

S Series motors in the 23 and 34 frame sizes (S57 and S83 series) are constructed with an 8 conductor motor cable to allow you to change the motor configuration on the connector at the drive. The 42 frame size motors (S106 series) are constructed with a 4-lead motor cable, but the motors can be configured by removing the cover plate on the back of the motor and rewiring at the screw terminals.

## S106-178 Series and Parallel Connections

The S106-178 is pre-wired in series. If you remove the motor's back panel, you can wire it in parallel.

### Series and Parallel

Motor Terminal #	Wire Color
1	Red
3	Black
5	Green
4	White

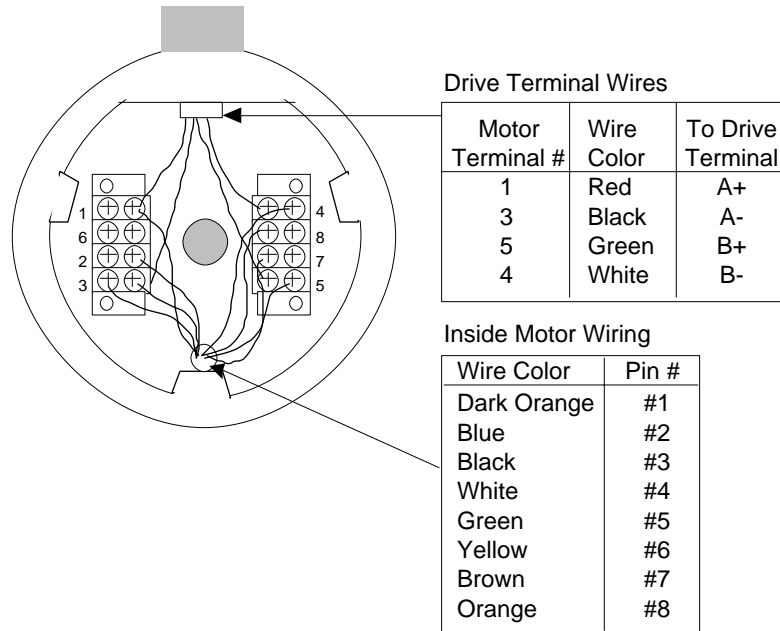

S106-178 Motor Wiring Diagram

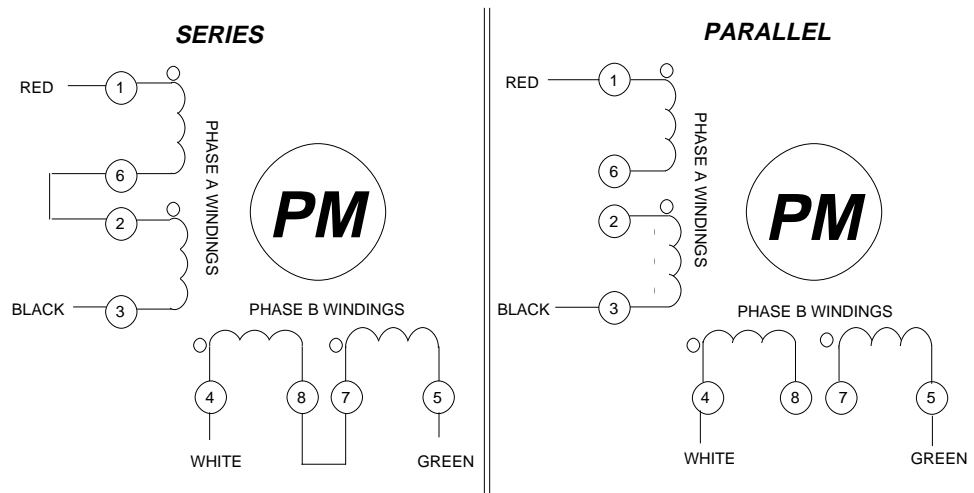

S106-178 Series and Parallel Connections

## S106-205 Series and Parallel Connections

The S106-205 is pre-wired in series. If you remove the motor's back panel, you can wire it in parallel.

### Series and Parallel

Motor Terminal #	Wire Color
1	Red
3	Green
5	Black
4	White

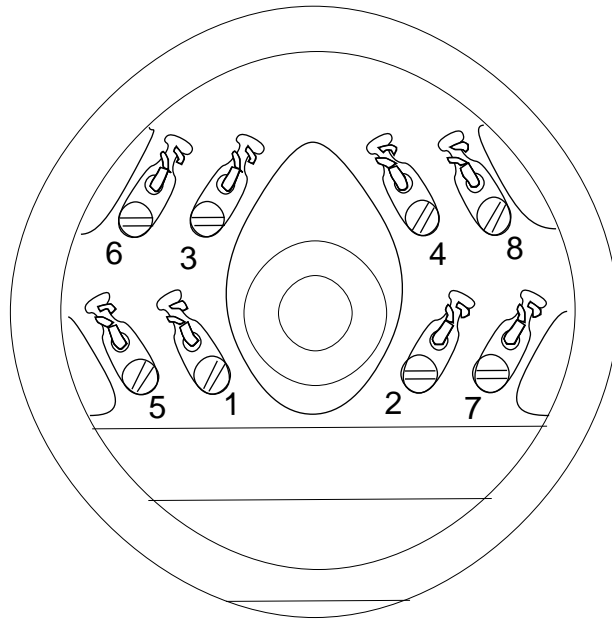

S106-205 Motor Wiring Diagram

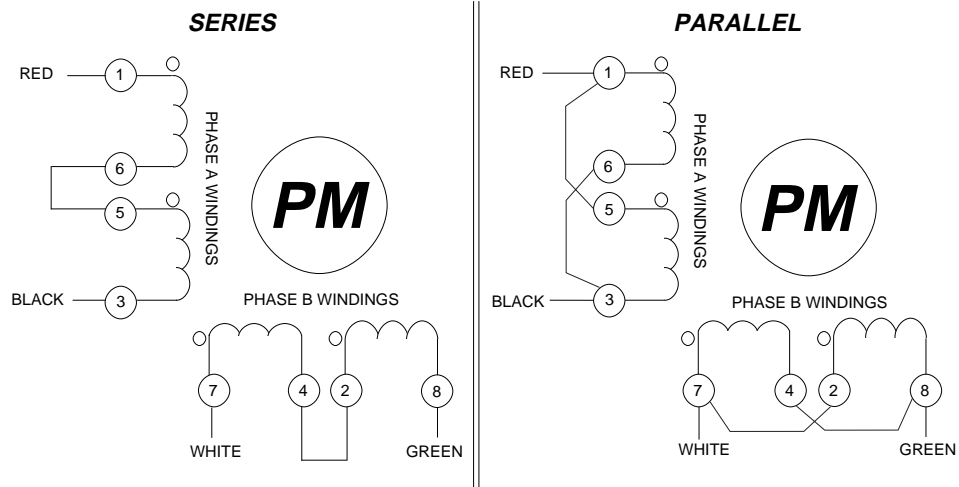

S106-205 Series and Parallel Connections

## S106-250 Series and Parallel Connections

The S106-250 is pre-wired in series. If you remove the motor's back panel, you can wire it in parallel.

### Series and Parallel

Motor Terminal #	Wire Color
1	Red
3	Black
4	White
5	Green

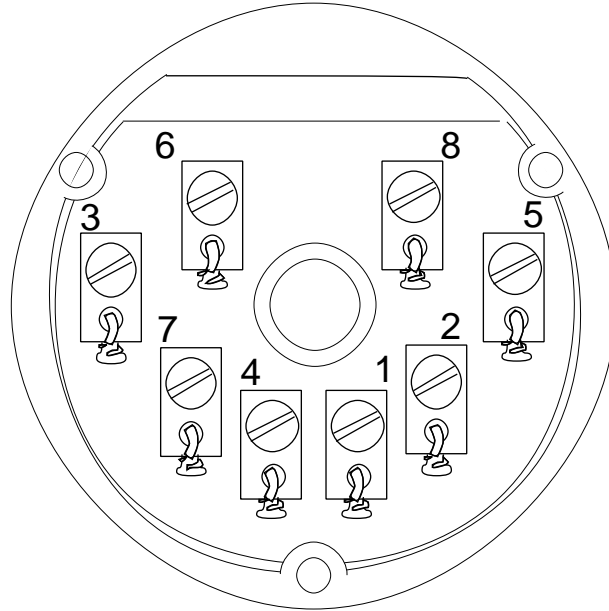

S106-250 Motor Wiring Diagram

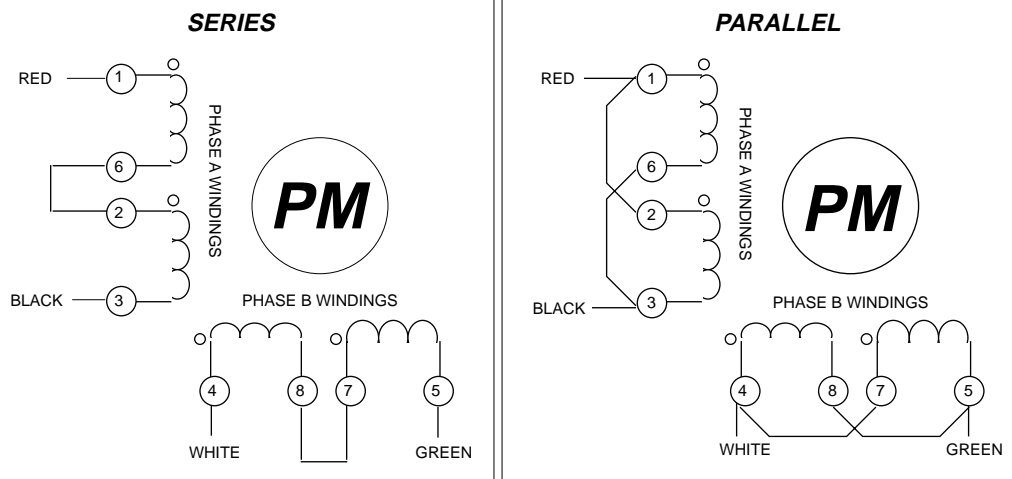

S106-250 Series and Parallel Connections

## 9-Pin Motor Connector

The *9-pin version* of the **MOTOR** connector is shown below. Before connecting the motor, determine which motor wires correspond to Phase A and Phase B. The 9-pin motor connector provides for easier installation when the motor is wired in series. **A-CT** and **B-CT** are not connections—they are terminal blocks.

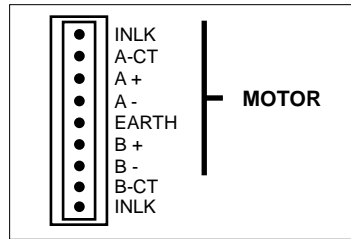

*S Drive 9-Pin Motor Connector*

The following tables show the color codes for the following types of motor connections to the S Drive 9-pin **MOTOR** connector.

- 8 Lead Motors—Series (S57 and S83)
- 8 Lead Motors—Parallel (S57 and S83)
- 4 Lead Motors—Series or Parallel (S106)

Pin	Color
A-CT	Yellow & Blue
A+	Red
A-	Black
EARTH	Shield
B+	White
B-	Green
B-CT	Orange & Brown
Jumper INLK to INLK	

*Color Code—9-Pin Connector/8 Lead Motor (Series)*

Pin	Color
A-CT	N.C.
A+	Red & Blue
A-	Black & Yellow
EARTH	Shield
B+	White & Brown
B-	Green & Orange
B-CT	N.C.
Jumper INLK to INLK	

*Color Code—9-Pin Connector/8 Lead Motor (Parallel)*

Pin	Color
A-CT	N.C.
A+	Red
A-	Black
EARTH	Shield
B+	White
B-	Green
B-CT	N.C.
Jumper INLK to INLK	

*Color Code—9-Pin Connector/4Lead Motor (S & P)*

Once you determine the wiring configuration, connect the motor to the drive's screw terminals according to the appropriate color code table. The following instructions should also be completed.

- ① Connect shield to the **MOTOR** connector's shield. **This is a very important safety precaution.** If your motor does not have a ground (shield) wire, attach a lug to the motor case and connect the motor to **EARTH**.
- ② Connect a short jumper wire from **INLK** (first pin of connector) to **INLK** (last pin of connector). This is a connector interlock. The drive will not operate if this jumper is missing or extended.

## Extended Motor Cables

The table below contains the recommended motor cables for various motor types and the minimum recommended motor/driver wire size (AWG) and resistance.

Motor Series	Maximum Current Per Winding (Amps)	Less than 100 ft. (20.5M)	100 - 200 ft. (30.5M - 71M)
S57	3	22 AWG	20 AWG
S83	6	20 AWG	18 AWG
S106	8	16 AWG	14 AWG

*Recommended Motor Cables*

*Cable runs of more than 200 feet (71M) are not recommended. Cable runs greater than 50 feet may degrade system performance.*

## Compumotor Motors—Setting Motor Current

You should verify which type of S Drive you have before setting motor current. The high-power drive (**S8**) provides bipolar 0 - 8 amps/phase (up to 2,400 oz-in). The low-power drive (**S6**) provides bipolar 0 - 6 amps/phase (up to 400 oz-in). You can determine which drive you have by checking the label on the side of the drive. The label identifies the unit as **S8 DRIVE** or **S6 DRIVE**. You must be aware of the drive's type to set the motor current correctly (using DIP switches). The tables below contain the proper motor current settings for Compumotor motors. **SW1-#1** through **SW1-#6** control *motor current*. Adjust the motor current to match the drive and motor that you are using. A complete list of all current motor current settings is provided in *Chapter ④ Hardware Reference*.

Motor Size	Current	SW1-#1	SW1-#2	SW1-#3	SW1-#4	SW1-#5	SW1-#6
S57-51S	1.18	off	off	on	on	off	off
S57-51P	2.28	off	on	on	off	off	off
S57-83S	1.52	off	on	off	off	off	off
S57-83P	3.09	on	off	off	off	off	off
S57-102S	1.71	off	on	off	off	on	off
S57-102P	3.47	on	off	off	on	off	off
S83-62S	2.19	off	on	off	on	on	on
S83-62P	4.42	on	off	on	on	on	off
S83-93S	2.85	off	on	on	on	on	off
S83-93P	5.62	on	on	on	off	on	on
S83-135S	3.47	on	off	off	on	off	off
S83-135P	6.00	on	on	on	on	on	on

S: Series Configuration P: Parallel Configuration

### S6 Drive Motor Current (Compumotor Motors)

Motor Size	Current	SW1-#1	SW1-#2	SW1-#3	SW1-#4	SW1-#5	SW1-#6
S106-178S	6.02	on	off	on	on	on	on
S106-178P	8.0	on	on	on	on	on	on
S106-205S	3.55	off	on	on	on	off	off
S106-205P	6.99	on	on	on	on	on	on
S106-250S	6.23	on	on	off	off	off	on
S106-250P	8.0	on	on	on	on	on	on

S: Series Configuration P: Parallel Configuration

### S8 Drive Motor Current (Compumotor Motors)

## Non-Compumotor Motors Drive/Motor Connection

Compumotor does not recommend that you use non-Compumotor motors with the S Drive. If you do use a non-Compumotor motor, it must meet the following requirements:

- A minimum inductance of 2 mH, series or parallel, may be used (Compumotor recommends a minimum inductance of 5 mH).
- A minimum of 500VDC high-pot insulation rating from phase-to-phase and phase-to-ground.
- The motor must not have riveted rotors or stators.
- Do not use solid rotor motors.
- Test all motors carefully. Verify that the motor temperature in your application is within the system limitations. *The motor manufacturer's maximum allowable motor case temperature must not be exceeded.* You should test the motor over a 2- to 3-hour period. Motors tend to have a long thermal time constant, but can still overheat, which results in motor damage.

---

---

### CAUTION

Consult a Compumotor Applications Engineer if you intend to use a non-Compumotor motor.

---

---

## Wiring Configurations

---

You can determine the motor's wiring configuration by referencing the manufacturer's motor specification document supplied with the motor. You can also determine the wiring configuration with an ohmmeter using the procedures below (*4-Lead Motor*, *6-Lead Motor*, *8 Lead Motor*). Once you determine the correct motor wiring configuration, use the terminal connection diagram that applies to your configuration (refer to the *Terminal Connections* section later in this chapter).

### 4-Lead Motor

- ① Label one motor lead **A+**.
- ② Connect one lead of an ohmmeter to the **A+** lead and touch the other lead of the ohmmeter to the three remaining motor leads until you find the lead that creates continuity. Label this lead **A-**.
- ③ Label the two remaining leads **B+** and **B-**. Verify that there is continuity between the **B+** and **B-** leads.
- ④ Proceed to the *Terminal Connections* section below.

### 6-Lead Motor

- ① Determine, with an ohmmeter, which three of the six motor leads are common (one phase).
- ② Label each one of these three motor leads **A**.
- ③ Using the ohmmeter, verify that the remaining three leads are common.
- ④ Label the other three leads **B**.
- ⑤ Set the ohmmeter range to approximately the 100 ohm scale.
- ⑥ Connect the negative lead of the ohmmeter to one of the motor leads labeled **A**. Alternately measure the resistance to the two remaining motor leads also labeled **A**. The resistance measurements will reflect one of the following scenarios:

👉 **Helpful Hint: Scenario #1**

The resistance measurements to the two remaining motor leads are virtually identical. Label the two remaining motor leads **A+** and **A-**. Label the motor lead connected to the negative lead of the ohmmeter **A-CT** (this is the center tap lead for Phase A of the motor).

### **Helpful Hint: Scenario #2**

The resistance measurement to the second of the three motor leads measures 50% of the resistance measurement to the third of the three motor leads. Label the second motor lead **A-CT** (this is the center tap lead for Phase A of the motor). Label the third motor lead **A-**. Label the motor lead connected to the ohmmeter **A+**.

- ⑦ Repeat the procedure as outlined in step 6 for the three leads labeled **B** (**B-CT** is the center tap lead for Phase B of the motor).
- ⑧ *If your S Drive has a 7-pin motor connector*, cover the two motor leads labeled **A-CT** and **B-CT** with electrical tape or shrink tubing to prevent these leads from shorting out to anything else. Do not connect these leads together or to anything else.  
*If your S Drive has a 9-pin motor connector*, connect the **A-CT** motor lead to the **A-CT** pin on the **MOTOR** connector. Connect the **B-CT** motor lead to the **B-CT** pin on the **MOTOR** connector.
- ⑨ Proceed to the *Terminal Connections* section below.

## 8-Lead Motor

Because of the complexity involved in phasing an 8-lead motor, you must refer to the manufacturer's motor specification document. You can configure the 8-lead motor in parallel or series. Using the manufacturer's specifications, label the motor leads as shown in the *Terminal Connections* section.

## Parallel Configuration

Use the following procedures for parallel configurations.

- ① Connect motor leads A1 and A3 and relabel this common point **A+**.
- ② Connect motor leads A2 and A4 and relabel this common point **A-**.
- ③ Connect motor leads B1 and B3 and relabel this common point **B+**.
- ④ Connect motor leads B2 and B4 and relabel this common point **B-**.

## Series Configuration

Use the following procedures for series configurations.

- ① *If your S Drive has a 7-pin motor connector*, connect the motor leads labeled A2 and A3 together and cover this connection with electrical tape or shrink tubing. Make sure these leads are not connected to the S Drive.  
*If your S Drive has a 9-pin motor connector*, you can connect A2 and A3 to **A-CT**. You may also connect B2 and B3 to **B-CT**.
- ② Relabel the A1 lead to **A+**.
- ③ Relabel the A4 lead to **A-**.
- ④ *If your S Drive has a 7-pin motor connector*, connect the motor leads labeled B2 and B3 together and cover this connection with electrical tape or shrink tubing. Make sure these leads are not connected to the S Drive.
- ⑤ Relabel the B1 lead to **B+**.
- ⑥ Relabel the B4 lead to **B-**.
- ⑦ Proceed to the *Terminal Connections* section the next page.

# Terminal Connections

After determining the motor's wiring configuration, connect the motor leads to the 9-pin or 7-pin **MOTOR** connector using the diagrams below.

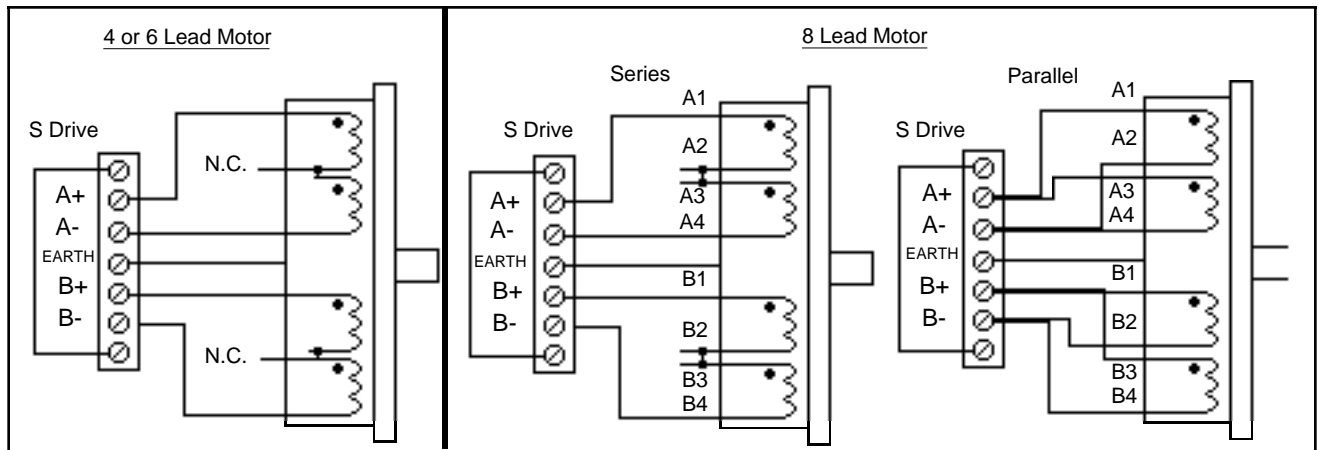

7-Pin Motor Connector (Non-Compumotor Motors)

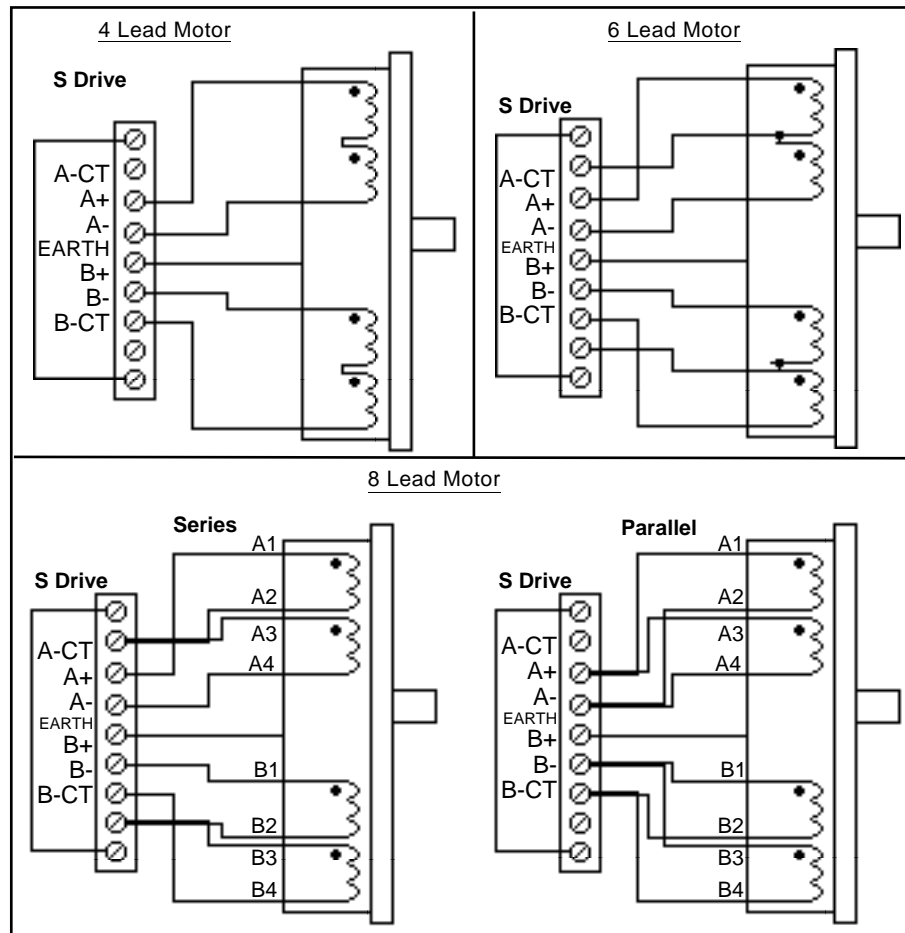

9-Pin Motor Connector (Non-Compumotor Motors)

## CAUTION

Do not connect or disconnect the motor with the power on.  
This will damage the contacts of the motor connector and may cause personal injury.

## Extended Motor Cables

The table below contains the recommended motor cables for various motor types and the minimum recommended motor/driver wire size (AWG) and resistance.

Motor Series	Maximum Current Per Winding (Amps)	Less than 100 ft. (20.5M)	100 - 200 ft. (30.5M - 71M)
S57	3	22 AWG	20 AWG
S83	6	20 AWG	18 AWG
S106	8	16 AWG	14 AWG

*Recommended Motor Cables*

*Cable runs of more than 200 feet (71M) are not recommended. Cable runs greater than 50 feet may degrade system performance.*

## Non-Compumotor Motors—Setting Motor Current

Compumotor does not recommend that you use non-Compumotor motors with the S Drive. If you do, refer to the formulas below that correspond to your motor (4-lead, 6-lead, or 8-lead) and use the S6/S8 motor current tables to set motor current. **Never increase current more than 10% above the specified rating.**

### 4-Lead Motors

If you use a 4-lead motor, the manufacturer's current setting will translate directly to the values shown in the S6/S8 motor current tables.

### 6-Lead Motors

If you use a 6-lead motor, and the manufacturer specifies the motor current as a unipolar rating, you must use the following formula to convert the unipolar current rating to the correct bipolar rating.

**Unipolar Current X .707 = Bipolar Current**

After you make the conversion, use S6/S8 motor current tables to set motor current. If the manufacturer specifies the motor current as a bipolar rating, you can use the motor current tables on the next page directly (no conversion) to set motor current.

### 8-Lead Motors

If you are using an 8-lead motor, manufacturers generally rate the motor current in one of two ways:

- If the motor current is listed as a unipolar rating, use the following formula to convert the unipolar current rating to the correct bipolar current rating.

**Unipolar Current X .707 = Bipolar Series Current**

If you are wiring the motor in *series*, use the motor current tables on the next page and the converted value to set the motor current.

If you wire the motor in *parallel*, you must **double** the converted value and use Table 3-11 or 3-12 to set the motor current.

- If the motor current is listed as a bipolar series rating, you can wire the motor in *series* and use the motor current tables on the next page directly (no conversion) to set motor current.

If the motor current is listed as a bipolar series rating and you wire the motor in *parallel*, you must **double** the manufacturer's rating and then use the motor current tables on the next page to set the motor current.

If you have any questions with regard to the configurations, please call Compumotor's Applications Engineering Department at 800-358-9070.

### Low-Power S6 Drive

Current	SW1	SW2	SW3	SW4	SW5	SW6	Current	SW1	SW2	SW3	SW4	SW5	SW6
0.04	off	off	off	off	off	off	3.09	on	off	off	off	off	off
0.13	off	off	off	off	off	on	3.19	on	off	off	off	off	on
0.23	off	off	off	off	on	off	3.28	on	off	off	off	on	off
0.32	off	off	off	off	on	on	3.38	on	off	off	off	on	on
0.42	off	off	off	on	off	off	3.47	on	off	off	on	off	off
0.51	off	off	off	on	off	on	3.57	on	off	off	on	off	on
0.61	off	off	off	on	on	off	3.66	on	off	off	on	on	off
0.70	off	off	off	on	on	on	3.76	on	off	off	on	on	on
0.80	off	off	on	off	off	off	3.85	on	off	on	off	off	off
0.89	off	off	on	off	off	on	3.95	on	off	on	off	off	on
0.99	off	off	on	off	on	off	4.04	on	off	on	off	on	off
1.08	off	off	on	off	on	on	4.14	on	off	on	off	on	on
1.18	off	off	on	on	off	off	4.23	on	off	on	on	off	off
1.27	off	off	on	on	off	on	4.33	on	off	on	on	off	on
1.37	off	off	on	on	on	off	4.42	on	off	on	on	on	off
1.46	off	off	on	on	on	on	4.51	on	off	on	on	on	on
1.52	off	on	off	off	off	off	4.58	on	on	off	off	off	off
1.62	off	on	off	off	off	on	4.68	on	on	off	off	off	on
1.71	off	on	off	off	on	off	4.77	on	on	off	off	on	off
1.81	off	on	off	off	on	on	4.86	on	on	off	off	on	on
1.90	off	on	off	on	off	off	4.96	on	on	off	on	off	off
2.00	off	on	off	on	off	on	5.05	on	on	off	on	off	on
2.09	off	on	off	on	on	off	5.15	on	on	off	on	on	off
2.19	off	on	off	on	on	on	5.24	on	on	off	on	on	on
2.28	off	on	on	off	off	off	5.34	on	on	on	off	off	off
2.38	off	on	on	off	off	on	5.43	on	on	on	off	off	on
2.47	off	on	on	off	on	off	5.53	on	on	on	off	on	off
2.57	off	on	on	off	on	on	5.62	on	on	on	off	on	on
2.66	off	on	on	on	off	off	5.72	on	on	on	on	off	off
2.76	off	on	on	on	off	on	5.81	on	on	on	on	off	on
2.85	off	on	on	on	on	off	5.91	on	on	on	on	on	off
2.95	off	on	on	on	on	on	6.00	on	on	on	on	on	on

Setting S6 Drive Motor Current (Non-Compumotor Motors)

### High-Power S8 Drive

Current	SW1	SW2	SW3	SW4	SW5	SW6	Current	SW1	SW2	SW3	SW4	SW5	SW6
0.05	off	off	off	off	off	off	4.12	on	off	off	off	off	off
0.18	off	off	off	off	off	on	4.25	on	off	off	off	off	on
0.30	off	off	off	off	on	off	4.38	on	off	off	off	on	off
0.43	off	off	off	off	on	on	4.50	on	off	off	off	on	on
0.56	off	off	off	on	off	off	4.63	on	off	off	on	off	off
0.69	off	off	off	on	off	on	4.75	on	off	off	on	off	on
0.81	off	off	off	on	on	off	4.89	on	off	off	on	on	off
0.93	off	off	off	on	on	on	5.01	on	off	off	on	on	on
1.06	off	off	on	off	off	off	5.14	on	off	on	off	off	off
1.19	off	off	on	off	off	on	5.26	on	off	on	off	off	on
1.31	off	off	on	off	on	off	5.39	on	off	on	off	on	off
1.44	off	off	on	off	on	on	5.51	on	off	on	off	on	on
1.59	off	off	on	on	off	off	5.64	on	off	on	on	off	off
1.69	off	off	on	on	off	on	5.77	on	off	on	on	off	on
1.82	off	off	on	on	on	off	5.90	on	off	on	on	on	off
1.94	off	off	on	on	on	on	6.02	on	off	on	on	on	on
2.03	off	on	off	off	off	off	6.11	on	on	off	off	off	off
2.16	off	on	off	off	off	on	6.23	on	on	off	off	off	on
2.28	off	on	off	off	on	off	6.36	on	on	off	off	on	off
2.41	off	on	off	off	on	on	6.48	on	on	off	off	on	on
2.54	off	on	off	on	off	off	6.61	on	on	off	on	off	off
2.66	off	on	off	on	off	on	6.73	on	on	off	on	off	on
2.79	off	on	off	on	on	off	6.87	on	on	off	on	on	off
2.91	off	on	off	on	on	on	6.99	on	on	off	on	on	on
3.04	off	on	on	off	off	off	7.12	on	on	on	off	off	off
3.17	off	on	on	off	off	on	7.24	on	on	on	off	off	on
3.297	off	on	on	off	on	off	7.37	on	on	on	off	on	off
3.42	off	on	on	off	on	on	7.49	on	on	on	off	on	on
3.55	off	on	on	on	off	off	7.62	on	on	on	on	off	off
3.67	off	on	on	on	off	on	7.75	on	on	on	on	off	on
3.80	off	on	on	on	on	off	7.87	on	on	on	on	on	off
3.93	off	on	on	on	on	on	8.00	on	on	on	on	on	on

Setting S8 Drive Motor Current (Non-Compumotor Motors)

## ③ Drive Configuration

In this section, you will set the following DIP switch selectable functions:

- Auto Standby function
- Motor Resolutions
- Motor Waveforms
- Auto Run function

### Automatic Standby Function

The Automatic Standby function allows the motor to cool when it is not moving. This function reduces the current to the motor when the drive does not receive a step pulse for one second. Switches **SW1-#7** through **SW1-#8** control Automatic Standby. Full power is restored upon the first step pulse that the drive receives. *Do not use this function in systems that use an indexer and an encoder for position maintenance. If used in this environment, the system will go in and out of the Auto Standby mode.*

Current	SW1-#7	SW1-#8
* Full Current	off	off
75%	on	off
50%	off	on
25%	on	on

\* Default Setting

*Automatic Standby Function*

### Motor Resolutions

Switches **SW2-#1** - **SW2-#4** control motor resolution. **Your indexer and drive must be set to the same resolution.** If the drive and indexer's motor resolution settings do not match, commanded accelerations and velocities will not be performed accurately.

Resolution	SW2-#1	SW2-#2	SW2-#3	SW2-#4
50,800 steps	off	off	off	on
50,000 steps	off	off	on	off
36,000 steps	off	off	on	on
25,600 steps	off	on	off	off
25,400 steps	off	on	off	on
* 25,000 steps	off	off	off	off
21,600 steps	off	on	on	off
20,000 steps	off	on	on	on
18,000 steps	on	off	off	off
12,800 steps	on	off	off	on
10,000 steps	on	off	on	off
5,000 steps	on	off	on	on
2,000 steps	on	on	off	off
1,000 steps	on	on	off	on
400 steps	on	on	on	off
200 steps	on	on	on	on

\* Default Setting

*Motor Resolution Settings*

## Motor Waveforms

Motor Waveforms help you to overcome resonance problems and allow the motor to run smoothly. DIP switches **SW2-#5** through **SW2-#7** control the waveform shape. *This function will not operate when the 200- and 400-step motor resolutions are used.*

Waveform Shape	SW2-#5	SW2-#6	SW2-#7
Pure Sine	on	on	off
-2% 3rd harmonic	on	off	on
* <b>-4% 3rd harmonic</b>	<b>off</b>	<b>off</b>	<b>off</b>
-4% 3rd harmonic	on	on	on
-4% 3rd harmonic	on	off	off
-6% 3rd harmonic	off	on	on
-8% 3rd harmonic	off	on	off
-10% 3rd harmonic	off	off	on

\* *Default Setting*

*Motor Waveform Settings*

## Automatic Test Function

The Automatic Test (*DIP switch SW2-#8*) function turns the motor shaft slightly less than six revolutions in Alternating mode at 1 rps. The Automatic Standby function and motor resolution settings are disabled when you use the Automatic Test function.

* <b>SW2-#8 OFF Disables Auto Test</b>
<b>SW2-#8 ON Enables Auto Test</b>

\* *Default Setting*

## ④ Drive/Indexer Connection

 **Helpful Hint: For drive/indexer wiring instructions, refer to *Installation Overview***

If you are using a Compumotor indexer, plug the indexer cable into the S Drive's **INDEXER** connector. If you are using a non-Compumotor indexer, the indexer must meet the specifications listed below.

### Step & Direction Signal Specification

The inputs are optically isolated and may be driven (activated) by applying a positive pulse to the *plus* input with respect to the *minus* input (refer to input schematic below.). These inputs may also be differentially driven. The input driver must provide a minimum of 6.5 mA (15 mA maximum).

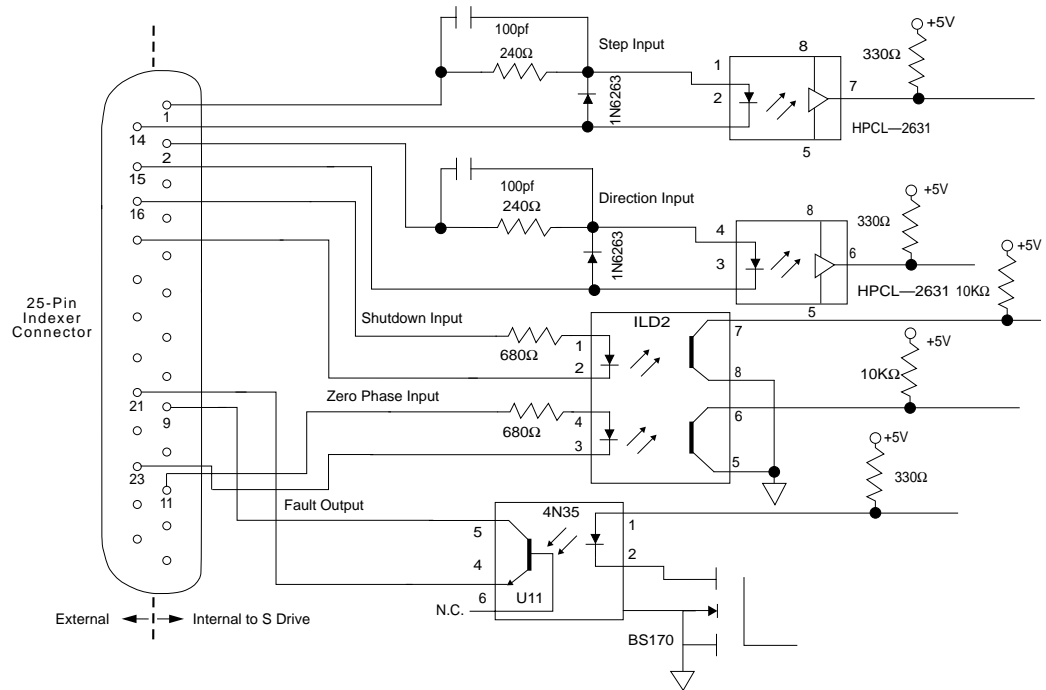

*S Drive I/O Schematic*

### Step Pulse Input

You must operate the step pulse input within the following guidelines.

- 200 nanosecond-pulse minimum
- 40% - 60% duty cycle (2 MHz max pulse rate)

### Direction Input

The direction input may change polarity coincident with the last step pulse. The direction input must be stable for at least 2 ms before the drive receives the first pulse.

### Shutdown & Set Zero Phase Signal Specification

The inputs are optically isolated and may be driven (activated) by providing a positive pulse to the *plus* input with respect to the *minus* input. *The input driver must provide a minimum of 2.5 mA (30 mA maximum). The maximum reverse voltage for this input is 3VDC.*

### Shutdown Input (Amplifier Disable)

You may enable this function when the motor is not moving. The input must be active for 100 ms to disable the amplifier. The **SHUTDOWN** input must be inactive for 100 ms before the first step pulse is received.

## Set Zero Phase Input

This input allows you to reset the motor phase currents to the power up position. It is primarily for linear motor applications. The input must be active for 100 ms to reset the motor phase currents to the zero state. The SET ZERO PHASE input must be inactive for 100 ms before the first step pulse is received.

## Fault Output

This output is an open-collector, open emitter output from a 4N35 OPTO isolator. The output transistor will conduct when the drive is functioning properly. The transistor will not conduct when any of the following conditions exist:

- No power is applied to the drive
- There is insufficient AC line voltage (90VAC)
- The drive temperature is too high
- The drive detects a motor fault
- The Shutdown input is enabled

### **Helpful Hint: Output Electric Parameters**

This output has the following characteristics:

- $V_{CE} = 35\text{VDC}$
- $V_{CESAT} = 0.3\text{VDC}$
- Collector Current = 10 mA minimum
- Dissipation = 100 mW maximum

## ⑤ Fan Connection

---

The fan kit is a standard feature of the **S8** (high-power) Drive. If you are using the **S6** (low-power) Drive, you may order the fan kit from your ATC or Compumotor Distributor. *Ensure that the fan is always on when the S8 Drive is on.*

## ⑥ AC Power Connection

---

### **Helpful Hint: Refer to the Installation Overview for more on the power connection**

The S Drive includes a standard molded power cable. Simply plug the power cable into the fan kit's power connector and a 90VAC - 132VAC power source.

---

---

### **CAUTION**

AC power to the S Drive is limited to 132VAC.  
Higher voltages will damage the drive. The low-voltage limit is 90VAC.

---

---

# Transformers

An isolation transformer (optional) can enhance the system’s electrical noise immunity. Refer to the *Transformer Specifications* section for instructions on sizing a transformer for your application. Use the transformer user guide and the diagram below to connect the transformer leads to the AC power connector on the drive.

**WARNING**

Do not connect the transformer to the S Drive while power is applied to the transformer.  
Do not touch the wiring studs or terminals on the transformer after it is plugged into an AC outlet. Lethal voltages are present.

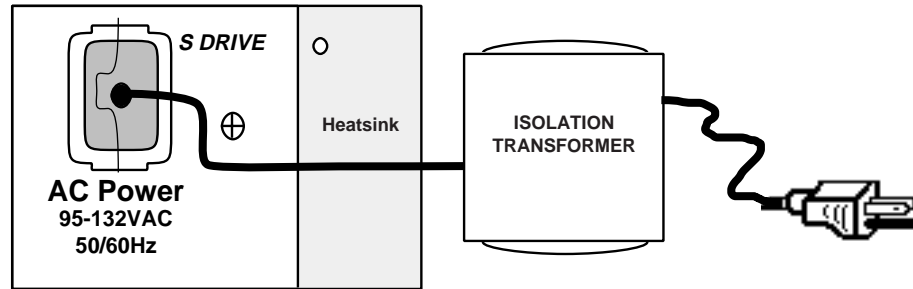

*Transformer Connections*

## Transformer Specifications

The tables below contain data to help system designers cool drives and motors, and size isolation transformers. Each of the tables’ fields is explained below. Combinations of motors and current levels other than those discussed in this section will result in power values that are not specified in this discussion.

**Helpful Hint: S Drive Power Ratings**

S Series motors are shipped in series. You may re-wire the motor (see Wiring Configurations). Parallel configurations provide more torque than series configurations provide at high speeds. You must use precautionary measures to prevent overheating when motors wired in parallel configurations are used (see *Non-Compumotor—Drive/Motor Connection*).

Motor Type	Current (Amps)	Cabinet Loss (Watts)	Peak Motor Loss (Watts)	Peak Shaft Power (Watts)	Peak Total Power (Watts)	Volt-Amp Rating (VA)
S57-51S	1.15	11.2	25	55	90	140
S57-51P	2.30	15.8	50	110	180	270
S57-83S	1.55	12.7	27	72	110	170
S57-83P	3.1	19.8	54	144	218	335
S57-102S	2.0	14.5	30	95	140	215
S57-102P	4.0	25.1	60	190	280	420
S83-62S	2.0	14.5	50	120	190	280
S83-62P	4.0	25.1	100	240	370	560
S83-93S	2.8	18.2	52	172	240	370
S83-93P	5.6	36.6	104	343	480	740
S83-135S	3.45	21.8	57	205	280	440
S83-135P	6.0*	40.0	114	410	560	870

**S: Series Configuration P: Parallel Configuration \* S83-135P motors can be driven at 7A with an S8 Drive**

### S6 Drive Power Ratings

Motor Type	Cabinet Loss (Watts)	Peak Motor Loss (Watts)	Peak Shaft Power (Watts)	Peak Total Power (Watts)	Volt-Amp Rating (VA)
S106-178S	20	140	350	510	790
S106-178P	30	280	700	1010	1570
S106-205S	40	290	460	790	1230
S106-250S	30	160	360	550	860
S106-250P	40	300	700	1040	1620

**S: Series Configuration P: Parallel Configuration**

### S8 Drive Power Ratings

### **Helpful Hint: Calculations**

- To convert watts to horsepower, **divide by 746**.
- To convert watts to BTU/hr, **multiply by 3.413**.
- To convert watts to BTU/min, **multiply by 0.0569**.

## **Motor Type**

Compumotor S Series motors are custom-made for use with S Drives. They are not available as a standard model from any other manufacturer. These motors are designed for low loss at rest and at high speed. Motors in the same frame sizes from other manufacturers may sustain considerably higher iron losses than an S Series motor. S Series motors are wound to render inductances within a particular range suitable for S Drives. If you intend to use a motor other than an S Series motor, you should consult Compumotor's Applications Engineering Department for motor heating and drive performance consequences (800-358-9068). The S Drive is intended for use with 2 phase PM step motors only. Do not use variable inductance or DC motors.

## **Current (Amps)**

Compumotor has assigned the current ratings shown in the previous tables for S Series motors to produce the highest possible torque while maintaining smoothness. Use of higher currents will produce higher static torque; however, the motor will run rough and may overheat. The selected current setting for a motor wired in parallel is twice the value of the current setting selected for that motor wired in series. Do not run the parallel rated current into a motor that is wired in series—it will destroy the motor's windings.

## **Cabinet Loss**

The total thermal dissipation in the S Drive is almost constant, regardless of whether the motor is stationary or in motion. The current output switch settings determine the motor phase currents that cause power losses. The cabinet's thermal resistance is approximately 0.35°C/W in still air with the heatsink fins vertically positioned. For 6A operation, the cabinet will rise approximately 15°C above ambient temperature. The fan kit (which is optional for S6 Drives) will reduce this temperature rise to 2°C. End item design must prevent ambient temperature around the drive from exceeding 50°C (temperatures above 50°C will activate the drive's thermal shutdown feature). If the appropriate temperature cannot be maintained, the fan kit must be installed.

## **Peak Motor Loss**

As the speed of a motor increases, the *core losses* (hysteresis and eddy current) increase to the level where the motor loses torque. The peak dissipation includes core and copper losses. The data shown in *Drive Power Rating* tables above do not indicate average power unless the motor is run almost continuously at high speed. Average motor loss will generally be less than these figures depending on the duty cycle and dwell times. Motor losses are almost entirely independent on the mechanical load. ***Motor losses are not related to shaft power.***

S Series motors that are wired in series can be run continuously at speeds that incur peak motor loss. S Series motors that are wired in parallel, however, cannot be run at peak motor loss levels continuously without overheating (unless extensive cooling measures are employed). Most applications do not require continuous slewing at high speed. Therefore, the average motor loss will be within safe limits (refer to the motor sizing information provided in Compumotor's sizing software).

Do not run the S Drive with motors in a parallel configuration without inspecting the thermal behavior of the system. A parallel motor that operates at peak motor loss does not sustain damage immediately. Approximately 10 - 30 minutes of continuous operation may be required to reveal an overheating problem. In general, the motor's case temperature should not exceed 100°C.

## Peak Shaft Power

Peak shaft power is the product of torque and velocity in the region where the speed/torque curve appears as a hyperbola. In that speed range, available shaft power is essentially constant at this peak value. Most applications don't use more than 50% of the available peak shaft power. Use the peak shaft power values shown in the *Drive Power Rating* tables to determine the maximum demand on the primary power source.

## Peak Total Power

Peak total power is the sum of cabinet loss + peak motor loss + peak shaft power (refer to *S Drive Power Tables*). The average demand will be significantly less than the values provided in the tables depending on duty cycles at high speed and dwell times at rest.

## Volt-Amp Rating

S Drives obtain DC power by directly rectifying 120VAC, 60 Hz voltage. This is a low-cost, light-weight, small-size method of obtaining power. However, such a power supply represents a low-power factor to the line ( $\pm 0.65$  for S Drives). The volt-amp ratings provided in the *Drive Power Rating* tables were calculated by dividing *peak total power* by 0.65.

## Summary

Selecting an isolation transformer based on these will provide you with a conservatively rated system. For slow-speed or light-duty applications, smaller VA ratings may be appropriate.

## 7 Testing the System

---

With no power applied to the drive, perform the following steps to test your installed S Drive system.

- ① Ensure that all DIP switches are properly set for the motor and indexer that you are using.
  - Motor Current
  - Automatic Standby Function
  - Motor Resolution (must match indexer)
  - Motor Waveform
  - Automatic Test Function (should be off)
- ② Check your connections. Ensure that the system is properly configured.
- ③ **Apply power to the system** (*if you have a high-power drive—S8, be sure to power up the drive and the fan*).
- ④ Using the indexer, send step pulses to the drive that will rotate the motor one **CW** revolution at an acceleration of 1 rps<sup>2</sup> and a velocity of 1 rps.

When the drive receives the step pulses, the motor should rotate one **CW** revolution. The **green POWER** LED and the **green STEP** LED should be on when the drive receives pulses.
- ⑤ Using the indexer, send step pulses to the drive that will rotate the motor one **CCW** revolution at an acceleration of 1 rps<sup>2</sup> and a velocity of 1 rps.

When the drive receives the step pulses, the motor should rotate one **CCW** revolution. The **green POWER** LED and the **green STEP** LED should be on when the drive receives pulses.
- ⑥ Now you will test the Shutdown input. With no step pulses applied to the drive, activate the Shutdown input. Refer to your indexer's operations manual for instructions on activating the Shutdown input.

By activating the Shutdown input, all current will be removed from the motor. You should be able to turn the motor shaft manually. Try to turn the shaft slowly now. If you can turn it easily, the Shutdown input is working properly. If the shaft still has torque, check your wiring and try the test again.

## ⑧ Drive Mounting

You can mount the S Drive in a minimum depth or width configuration, depending on the position of the mounting clips. *Use only 6-32 X 1/4" screws to attach the mounting clips. Longer screws may damage the drive.*

### Minimum Width

Two clips are attached to the side of the drive away from the power connectors for minimum width. This provides the maximum amount of panel space. **The drive is shipped in this configuration.**

### Minimum Depth

You can move the clips from the minimum width position to the side opposite the heatsink to create a minimum depth configuration.

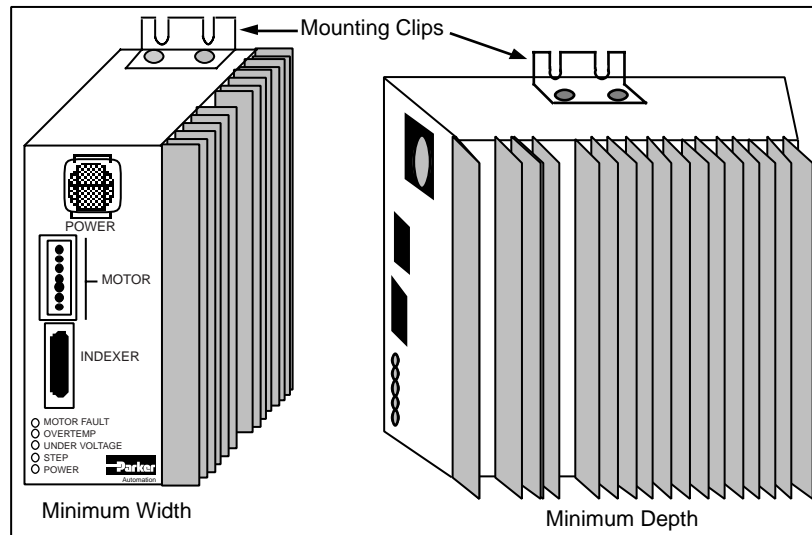

*Mounting the Drive*

---

#### **WARNING**

If you mount the drive in the minimum depth configuration, the screws (6-32) used to attach the mounting clips to the drive must not be longer than 0.25". Longer screws may damage the internal printed circuit board.

---

## Panel Layout

If you mount the S Drive in an enclosure, observe the following guidelines:

- The vertical and horizontal clearance between the S Drive and other equipment, or the top/bottom of the enclosure, should be no less than 4".
- Do not mount large, heat-producing equipment directly beneath the S Drive.
- Do not mount the S Drive directly below an indexer (the S Drive produces more heat than an indexer).
- Fan cooling may be necessary if air flow is not adequate.

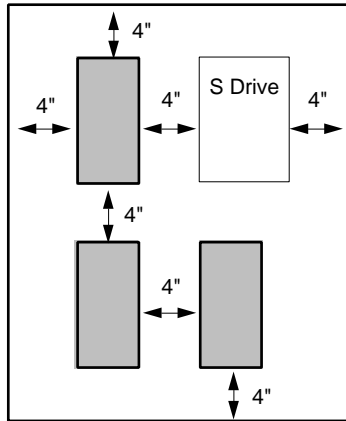

Panel Layout Guidelines

## Motor Mounting

Rotary stepper motors should be mounted using flange bolts and positioned with the centering flange on the front face. Foot-mount or cradle configurations are not recommended because the torque of the motor is not evenly distributed around the motor case and they offer poor registration. Any radial load on the motor shaft is multiplied by a much longer lever arm when a foot mount is used rather than a face flange.

---

---

### **WARNING**

Improper mounting can compromise system performance and **jeopardize personal safety**.

---

---

The motors used with the S Drive can produce very large torques. These motors can also produce high accelerations. This combination can shear shafts and mounting hardware if the mounting is not adequate. High accelerations can produce shocks and vibrations that require much heavier hardware than would be expected for static loads of the same magnitude. The motor, under certain profiles, can produce low-frequency vibrations in the mounting structure. These vibrations can also cause metal fatigue in structural members if harmonic resonances are induced by the move profiles you are using. A mechanical engineer should check the machine design to ensure that the mounting structure is adequate. **Do not attach the load to the motor yet. Coupling the load to the motor is discussed later in this chapter.**

---

---

### **CAUTION**

Consult a Compumotor Applications Engineer [800-358-9070] before you machine the motor shaft. Improper shaft machining can destroy the motor's bearings. *Never* disassemble the motor (it will cause a significant loss of torque).

---

---

## ⑨ Attaching the Load

---

This section discusses the main factors involved when attaching the load to the motor. The following three types of misalignments can exist in any combination.

### Parallel Misalignment

The offset of two mating shaft center lines, although the center lines remain parallel to each other.

### Angular Misalignment

When two shaft center lines intersect at an angle other than zero degrees.

### End Float

A change in the relative distance between the ends of two shafts.

## Couplings

**The motor and load should be aligned as accurately as possible. Any misalignment may degrade your system's performance.**

There are three types of shaft couplings: single-flex, double-flex, and rigid. Like a hinge, a single-flex coupling accepts angular misalignment only. A double-flex coupling accepts both angular and parallel misalignments. Both single-flex and double-flex, depending on their design, may or may not accept end-play. A rigid coupling cannot compensate for any misalignment.

### Single-Flex Coupling

When a single-flex coupling is used, one and only one of the shafts must be free to move in the radial direction without constraint. *Do not use a double-flex coupling in this situation—it will allow too much freedom and the shaft will rotate erratically; this will cause large vibrations and immediate failure.*

### Double-Flex Coupling

Use a double-flexed coupling whenever two shafts are joined that are fixed in the radial and angular direction (angular misalignment). *Do not use a single-flex coupling with a parallel misalignment; this will bend the shafts, causing excessive bearing loads and premature failure.*

### Rigid Coupling

Rigid couplings are generally not recommended. They should be used only if the motor is on some form of floating mounts which allow for alignment compensation.

#### **Helpful Hint: Coupling Manufacturers**

HELI-CAL  
901 McCoy Lane  
P.O. Box 1460  
Santa Maria, CA 93456  
(805) 928-3851

ROCOM CORP  
5957 Engineer Drive  
Huntington Beach, CA 92649  
(714) 891-9922

*For unusual motor installations, call Compumotor for assistance (800-358-9070).*

# Tuning

---

This section contains the issues and concerns that you should be aware of as you tune and develop your system.

- Resonance
- Mid-Range Instability

## Resonance

Resonance exists in all stepper motors and is a function of the motor's mechanical construction. It can cause the motor to stall at low speeds. Most full-step motor controllers *jump* the motor to a set minimum starting speed that is greater than the resonance region. The S Drive's microstepping capability allows you to run a motor smoothly at low speeds.

*Motors that will not accelerate past 1 rps may be stalling due to resonance. You can add inertia to the motor shaft by putting a drill chuck on the shaft. The drill chuck may provide enough inertia to test the motor when it is **not loaded**. In extreme cases, a viscous damper may also be needed. Refer to Chapter ④ Hardware Reference for your motor's maximum inertia rating.*

The S Drive is factory tuned to minimize resonance problems. If you are running the S Drive at motor resolutions of 200 or 400 steps/rev, you may need an indexer that provides start/stop speed.

## Mid-Range Instability

All step motors are subject to mid-range instability, also referred to as parametric oscillations. These oscillations may stall the motor at speeds from 6 to 16 rps.

## Tuning Procedures

You can tune the S Drive to minimize resonance and optimize smoothness by adjusting the small potentiometers (pots) on the bottom of the unit. The diagram shows the location of the potentiometers and their functions. A description of each function is listed below.

- Phase A Offset: Adjusts the DC offset of the phase current for Phase A.
- Phase B Offset: Adjust the DC offset of the phase current or Phase B.
- Phase Balance: Adjust the Phase current of Phase B to  $\pm 10\%$  of Phase A.

It is not usually necessary to adjust these pots, tuning is done at the factory. Adjustments should be made only if the load inertia is greater than 2-3 times that of the rotor inertia. For best results, the drive and motor should be on, connected to the load, and warmed up for 30 minutes prior to tuning.

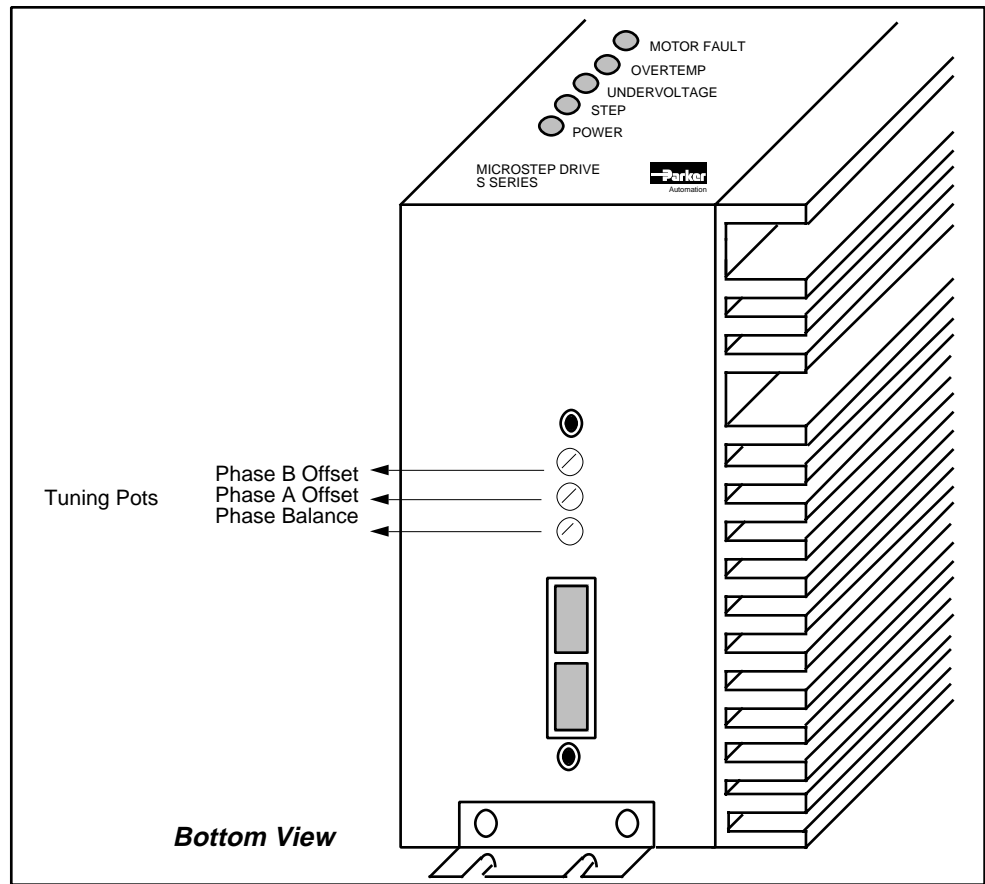

Location of Tuning Pots

## Gauging Motor Resonance

There are several methods that you can use to determine the level of motor resonance in your system.

### Tachometer Method

Use an oscilloscope to gauge the output of a tachometer attached to the motor shaft. The tachometer will output a DC voltage, proportional to speed. This voltage will oscillate around an average voltage when the motor is resonating. The amplitude of this oscillation will be at its maximum when you run the motor at its *resonance speed*. The goal of this tuning method is to tune the motor for its lowest oscillation amplitude.

### Sounding Board Method

You can practice your tuning skills with an unloaded motor placed on a sounding board or table. When you command a velocity that is near the motor's *resonance speed*, the phenomenon will cause an audible vibration. The goal of this tuning method is to tune the motor for the least amount of vibration.

### Stethoscope Method

When you tune your motor under loaded conditions, you can hear the audible vibration caused by the motor's natural frequency by placing the tip of a screw driver against the motor casing and placing the handle of the screw driver close to your ear (as you would a stethoscope). You will also be able to hear the different magnitudes of vibration caused by the motor's natural frequency. The goal of this tuning method is to tune the motor for the least amount of vibration.

### Touch Method

After you have had some experience with tuning, you should be able to locate the motor's *resonance speed* by placing your fingertips on the motor shaft and adjusting the motor's velocity. Once the *resonance speed* is located, you can tune the motor for maximum smoothness in the same way.

## Tuning the Drive to the Motor

Please note that system tuning has been done at the factory. To tune the drive, it is suggested that you first return the potentiometers to their center positions.

- ① Locate the motor's natural resonant frequency.  
A table for resonant frequencies for unloaded Compumotor motors is shown below.  
By varying the speed lightly from the values given in the table below. Locate the speed of worst resonance.  
Adjust the Phase A and Phase B offset potentiometers (located on the bottom of the drive), for best smoothness. Iterative tuning is recommended (adjust Phase A Offset, then B, then A, etc. until no improvement in smoothness is noted).
- ② Decrease the motor's velocity to half the value used in Step ①  
Adjust the Phase Balance Potentiometer for best smoothness.

## Optional Fine Tuning

- ③ Decrease the motor's velocity by half.  
Adjust the Waveform Symmetry DIP switches, located on the bottom of the drive, for best smoothness.  
Repeat the above procedure until no further improvement in motor smoothness is noted.

Motor	Phase A & B Offsets (rps)	Phase Balance (rps)	Waveform Adjust (rps)
S57-51	5.15	2.57	1.29
S57-83	3.90	1.96	0.98
S57-102	3.75	1.88	0.94
S83-62	3.00	1.50	0.75
S83-93	2.97	1.48	0.74
S83-135	2.95	1.47	0.74
S106-178	2.11	1.06	0.53
S106-205	2.07	1.04	0.52
S106-250	2.67	1.34	0.67

## Motor Waveforms

Step motor manufacturers make every effort to design step motors that work well with sinusoidal current waveforms. However, due to physical limitations, most motors operate best with a current waveform other than a pure sine wave.

The purpose of adjusting motor current waveforms is to set the step motor to move with a step size that is equal to the current waveforms that are sequenced through the motor. This *waveform matching* will also help the motor run more smoothly.

Motor waveforms are usually adjusted after the drive has been tuned to its motor. If you do not have precision measurement equipment, you may select the correct motor waveform with one of the three methods described previously in this chapter (Tachometer Method, Sounding Board Method, Stethoscope Method, and Touch Method). These empirical methods generally yield acceptable results.

## Rotary vs. Linear Indexers

---

Most Compumotor indexers are used for rotary motor systems. Hence, velocities and accelerations are selected in rps and rps<sup>2</sup> respectively. The default is often 25,000 steps per revolution. For linear motors, velocities and acceleration are usually defined in g's and inches per second (ips) respectively. Use the following equation to convert rps<sup>2</sup> to g's (1g = 386 ips<sup>2</sup>).

$$A[g] = \frac{A[\text{rps}^2] \cdot \text{Rotary Resolution} [\text{steps/rev}]}{\text{Linear Resolution} [\text{steps/in}] \cdot 386 \text{ ips}^2}$$

For example, if the rotary resolution is 25,000 steps/rev, the acceleration value is 100 rps<sup>2</sup>, and the linear resolution is 10,000 steps/in. The equation is as follows:

$$\frac{100 [\text{rps}^2] \cdot 25000 [\text{steps/rev}]}{10000 [\text{steps/in}] \cdot 386 \text{ ips}^2} = 0.648 \text{ g}$$

Use the following equation to convert rps to ips:

$$V[\text{ips}] = \frac{V[\text{rps}] \cdot \text{Rotary Resolution} [\text{steps/rev}]}{\text{Linear Resolution} [\text{steps/in}]}$$

For example, if the resolutions are the same as defined above, and the velocity value is 1 rps, the equation would be as follows:

$$\frac{1 [\text{rps}] \cdot 25000 [\text{steps/rev}]}{10000 [\text{steps/in}]} = 2.5 [\text{ips}]$$

### ☞ Helpful Hint: *Rotary vs Linear Indexer*

#### Example

- ① Set the unit with the following move parameters:
  - Acceleration = 1000 rps<sup>2</sup>
  - Velocity = 1 rps
  - Distance = 10,000 steps
- ② Execute the **G** (Go) command:

If the indexer's resolution is 25,000 steps/rev, the forcer should move 1 inch at a velocity of 2.5 ips.

