

APPENDIX B

# Using Non-Compumotor Motors

---

## IN THIS APPENDIX

---

- Commands for Motor Configuration
  - Wiring and Connections: 4-, 6-, and 8-lead motors
  - Setting Motor Current and Drive Gains
-

## Commands for Configuration

---

If you use a non-Compumotor motor, you must configure the drive for your motor by setting values for all commands in the following table. Also see the *Motor Parameters* table on the *Motion Planner CD-ROM* for examples of recommended drive configuration settings for Compumotor motors.

### Commands for Motor Configuration

Command	Description
DMTSTT	static torque
DMTIC	continuous current
DMTIND	inductance
DMTRES	phase resistance
DMTJ	rotor inertia
DPOLE	number of pole pairs
DIGNA*	current loop gain
DIGNB*	current loop gain
DIGNC*	current loop gain
DIGND*	current loop gain

\*See the *Gemini Series Programmer's Reference* for instructions on calculating DIGN values

Use Motion Planner or Pocket Motion Planner to enter these command settings into the drive's memory.

## Motor Requirements

---

We recommend that you use Compumotor motors with the Gemini drive. If you use a non-Compumotor motor, it must meet the following requirements:

- Inductance:      minimum:      0.5 mH  
                          recommended:   5.0 – 50.0 mH  
                          maximum:       100.0 mH
- A minimum of 500VDC high-pot insulation rating from phase-to-phase and phase-to-ground.
- The motor must be designed for use with a bipolar drive (no common center tap).
- The motor must not have riveted rotors or stators.
- Do not use solid rotor motors.
- Test all motors carefully. Verify that the motor temperature in your application is within the system limitations. *The motor manufacturer's maximum allowable motor case temperature must not be exceeded.* You should test the motor over a 2-to-3 hour period. Motors tend to have a long thermal time constant, but can still overheat, which results in motor damage.



**CAUTION**



Consult your motor vendor to verify that your motor meets the above specifications. Consult your Automation Technology Center (ATC) if you have questions regarding the use of a non-Compumotor motor with Compumotor equipment.

---

# Wiring Configurations

---

Refer to the manufacturer's motor specification document to determine the motor's wiring configuration. You can also determine the wiring configuration with an ohmmeter using the procedures below (*4-Lead Motor*, *6-Lead Motor*, *8-Lead Motor*). Once you determine the correct motor wiring configuration, use the terminal connection diagram, shown at the end of this section, that applies to your configuration.

## 4-Lead Motor

1. Label one motor lead **A+**.
2. Connect one lead of an ohmmeter to the **A+** lead and touch the other lead of the ohmmeter to the three remaining motor leads until you find the lead that creates continuity. Label this lead **A-**.
3. Label the two remaining leads **B+** and **B-**. *Verify that there is continuity between the **B+** and **B-** leads.*
4. Proceed to the *Terminal Connections* section below.

## 6-Lead Motor

1. Determine, with an ohmmeter, which three of the six motor leads are common (one phase).
2. Label each one of these three motor leads **A**.
3. Using the ohmmeter, verify that the remaining three leads are common.
4. Label the remaining three leads **B**.
5. Set the ohmmeter range to the 100 ohm scale (approximately).
6. Connect the ohmmeter's negative lead to one of the motor leads labeled **A**. Alternately measure the resistance to the two remaining motor leads also labeled **A**. The resistance measurements will reflect one of the following two scenarios.  
**Scenario #1** — The resistance measurements to the two remaining motor leads are virtually identical. Label the two remaining motor leads **A+** and **A-**. Label the motor lead connected to the negative lead of the ohmmeter **A CENTER TAP** (this is the center tap lead for Phase A of the motor).  
**Scenario #2** — The resistance measurement to the second of the three motor leads measures 50% of the resistance measurement to the third of the three motor leads. Label the second motor lead **A CENTER TAP** (this is the center tap lead for Phase A of the motor). Label the third motor lead **A-**. Label the motor lead connected to the ohmmeter **A+**.
7. Repeat the procedure as outlined in step 6 for the three leads labeled **B** (**B CENTER TAP** is the center tap lead for Phase B of the motor).
8. Proceed to the *Terminal Connections* section below.

## 8-Lead Motor

Because of the complexity involved in phasing an 8-lead motor, you must refer to the manufacturer's motor specification document. Using the manufacturer's specifications, label the motor leads as shown in the next drawing.

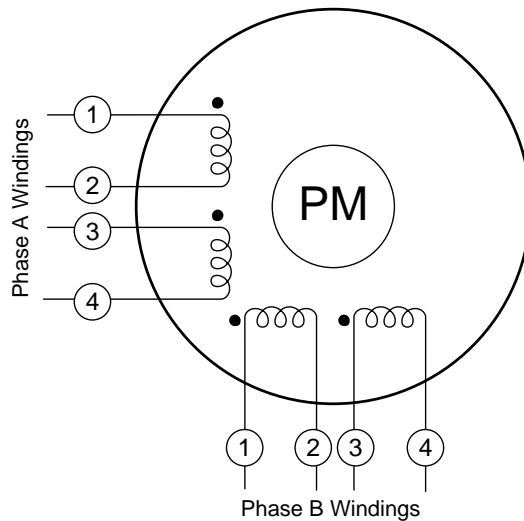

*8-Lead Motor – Labeling the Leads*

You can configure the 8-lead motor in series or parallel.

**Series Configuration** Use the following procedure for series configurations.

1. Connect A2 & A3 together and relabel this common point **A CENTER TAP**.
2. Connect B2 & B3 together and relabel this common point **B CENTER TAP**.
3. Relabel the A1 lead **A+**.
4. Relabel the A4 lead **A-**.
5. Relabel the B1 lead **B+**.
6. Relabel the B4 lead **B-**.
7. Proceed to the *Terminal Connections* section below.

**Parallel Configuration** Use the following procedure for parallel configurations.

1. Connect motor leads A1 & A3 together and relabel this common point **A+**.
2. Connect motor leads A2 & A4 together and relabel this common point **A-**.
3. Connect motor leads B1 & B3 together and relabel this common point **B+**.
4. Connect motor leads B2 & B4 together and relabel this common point **B-**.
5. Proceed to the *Terminal Connections* section below.

# Terminal Connections

After you determine the motor's wiring configuration, connect the motor leads to the Gemini drive's **MOTOR** connector according to the following figure.

## 4-Lead Motor

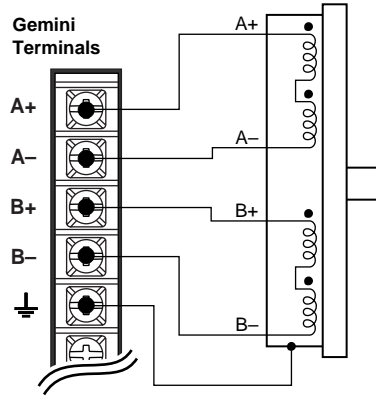

## 6-Lead Motor

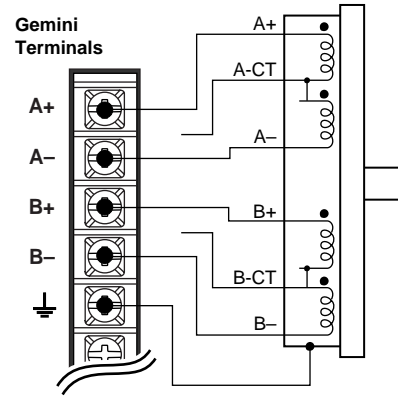

## 8-Lead Motor Series

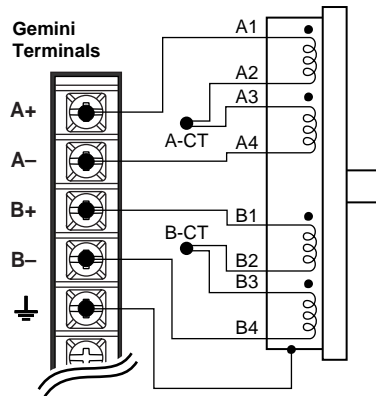

## 8-Lead Motor Parallel

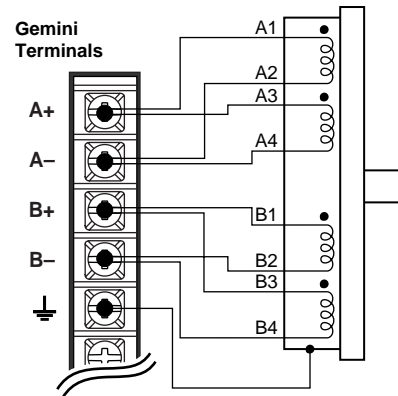

*Non-Compumotor Motor Connections*

## Direction of Motor Rotation

The procedures above do not determine the direction of motor shaft rotation. To find out which direction the shaft turns, you must power up your system and command motion. If the shaft turns in the opposite direction than you desire, exchange the motor leads connected to **A+** and **A-** to reverse the direction of rotation.



**WARNING**



Motor shaft rotation may be opposite than you expect. Do not connect a load to the shaft until you first determine the direction of shaft rotation.

---

---

*Autorun Mode*, described in *Chapter 2 Installation*, provides a simple method of determining motor shaft rotation. Autorun causes the shaft to rotate in the clockwise (positive) direction, if the motor wires are properly connected. A controller is not required for autorun.

## Setting Motor Current – Non-Compumotor Motors

---

To set motor current for a non-Compumotor motor, refer to the formulas below that correspond to your motor (4-lead, 6-lead, 8-lead) and use the DMTIC command to set the motor's current.

NOTE: Gemini *drive* specifications for output current are in amps *peak*. Most motor current specifications are in amps *rms*. The DMTIC command uses amps *rms*; *do not use amps peak with the DMTIC command*.



**WARNING**



Do not connect or disconnect the motor with the power on. Doing so will damage the contacts of the motor connector and may cause personal injury.

---

---

### 4-Lead Motors

If you use a 4-lead motor, the manufacturer's current specification will translate directly to the value you should enter with the DMTIC command.

### 6-Lead Motors

Manufacturers generally use either a bipolar rating or a unipolar rating for motor current in 6-lead motors.

**Bipolar Rating:** If the manufacturer specifies the motor current as a bipolar rating, you can use the DMTIC command directly to set motor current—no conversion is required.

**Unipolar Rating:** If the manufacturer specifies the motor current as a unipolar rating:

- Use the following formula to convert the unipolar current rating to the correct bipolar rating:

$$\text{Unipolar Current} * 0.707 = \text{Bipolar Current}$$

- Use the converted value and the DMTIC command to set the motor current.

## 8-Lead Motors

Manufacturers generally use either a bipolar rating or a unipolar rating for motor current in 8-lead motors.

**Bipolar Rating:** If the manufacturer specifies the motor current as a bipolar series rating:

- If you wire the motor in **series**, use the DMTIC command directly.
- If you wire the motor in **parallel**, you must double the manufacturer's rating and then use the DMTIC command to set the motor current.

**Unipolar Rating:** If the manufacturer specifies the motor current as a unipolar rating:

- Use the following formula to convert the unipolar current rating to the correct bipolar rating:

$$\text{Unipolar Current} * 0.707 = \text{Bipolar Current}$$

- If you wire the motor in **series**, use the converted value and the DMTIC command to set the motor current.
- If you wire the motor in **parallel**, you must **double** the converted value and use the DMTIC command to set the motor current.

If you have questions about setting motor current, call Compumotor's Applications Engineering Department at the number listed inside the front cover of this user guide.

## Setting Gains – Non-Compumotor Motors

---

If you use a non-Compumotor motor, you must use the DIGN command to manually set the gain terms for the stepper current loop. Setting the gain terms correctly will optimize drive performance for your specific motor. See the description of the DIGN command in the *Gemini Programmer's Reference* for instructions.

