

CHAPTER THREE

Specifications

IN THIS CHAPTER

- Drive Specifications
 - SM and NeoMetric Motor Specifications
 - SM and NeoMetric Motor Speed/Torque Curves
 - SM and NeoMetric Motor Dimensions
 - SM and NeoMetric Encoder Specifications
 - SM and NeoMetric Motor Part Numbering System
-

Drive Specifications – TQ10 & TQ10SD

Parameter	Value	
Performance		
Accuracy	±2 arc minute, encoder dependent	
Resolution	2000 or 4000 post-quadrature counts	
Drive Input Power		
Voltage	95–132 VAC	
Frequency	50/60 Hz	
Recommended Service	20 Amp RMS dedicated	
Drive Output Power		
Voltage	170VDC	
Switching Frequency	20 kHz	
Continuous Current	5 Amps with TQ-HS3 or mounted to heatsink at or below 45°C	
Peak Current	10 Amps with approximately 10 seconds maximum duration at 45°C	
Bandwidth	2 kHz typical (motor dependent)	
Commutation	6 state commutation; 120° open-collector Hall sensors, 6° (elec.) max. commutation error	
Inputs		
	TQ10	TQ10SD
Command	±10V 20K ohms input impedance	
Enable	Must be low or grounded to enable. 5-24 VDC to disable. Optically coupled with internal pull-up.	Must be low or grounded to enable. 5-24 VDC to disable. Optically coupled with internal pull-up.
Reset	Must be 5–24V or unconnected for normal operation. Ground to reset. Optically coupled with internal pull-up.	
Step		5V maximum input. Current 12 mA max. 6.3 mA min. 500 nS min. pulse width.
Direction		5V maximum input. Current 12 mA max., 6.3 mA min. 500 nS set up time. Positive voltage = CW motor rotation.
Shutdown		5V maximum input (24V with series resistor). Current 20 mA max., 6.3 mA min. +5V at SHUTDOWN+ input commands zero torque. Power stage still active.
Protection		
Short Circuit	Phase-to-phase, phase-to-earth	
Brownout	Below 80VAC	
Over temperature	Motor 90°C (194°F); Drive 65°C (150°F)	
Outputs		
	TQ10	TQ10SD
Reference	±15V, 10 mA available	
Encoder Power		+5VDC @ 200mA max
Fault+	5-24VDC, 20mA max current. Pull-up resistor needed. No fault, transistor on, current flows. Output turns off under fault condition	5-24VDC, 20mA max current. Pull-up resistor needed. No fault, transistor on, current flows. Output turns off under fault condition
Fault-		
Velocity Monitor		0–10VDC signal. 1VDC per 40 kHz post quadrature. 2 K ohms min load.
Motor-Mounted Encoder	SM and NeoMetric Motors use two-phase differential encoder outputs with line drivers. 20 mA sink or source. Max of 100 kHz pre-quadrature operating frequency.	
Physical		
Connections	10-pin removable screw terminal (all signal connection points)	
Motor	7-pin removable screw terminal	
Power	Standard 3-pin AC connection, molded plug	
Environment		
Drive Temperature – ambient	32°F to 122°F (0° to 50°C)	
Storage Temperature	-40°F to 185°F (-40°C to 85°C)	
Humidity	0 to 95% non-condensing	
Diagnostics		
	LED Name	Indication
LEDs	Enable (Bicolor)	Green = enabled Red = power on, not enabled
	Drive Temp	Red = drive overtemp
	Motor Fault	Red = fault (short circuit, motor overtemp, etc.)
	Peak Current/Foldback (Bicolor)	Green = current is near peak (over ~90%)
		Red = in foldback (peak current time exceeded)
	Regen (Bicolor)	Green = regen active Red = overvoltage fault
Faults (Hardware)	Short Circuit (phase-phase, phase-ground) Under voltage lock out (input <80 VAC) (no LED indication for this) Drive temperature	

Motor Specifications—Compumotor SM Series Servo Motors

	Symbol	Units	SM161A	SM162A	SM231A	SM232A	SM232B	SM233A	SM233B
Continuous Stall Torque ¹	T_{CS}	oz-in	24	44	46	92	92	140	140
		N-m	0.17	0.31	0.32	0.65	0.65	0.99	0.99
Continuous Stall Current ¹	I_{CS}	amps-rms	2.1	2.1	2.1	2.1	4.1	2.1	4.1
Rated Speed ²	ω_T	rpm	7,500	7,500	7,500	4,500	7,500	2,800	7,500
		rps	125	125	125	75	125	47	125
Peak Torque ¹	T_{pk}	oz-in	72	132	138	276	276	420	420
		N-m	0.51	0.83	0.97	1.95	1.95	2.97	2.97
Peak Current, rms ¹	I_{pk}	amperes	6.3	6.3	6.3	6.3	12.3	6.3	12.3
Torque @ Rated Speed ¹	T_C	oz-in	20	41	38	78	84	134	114
		N-m	0.14	0.29	0.27	0.55	0.59	0.95	0.81
Rated Power-Output Shaft ¹	P_o	Watts	110	222	205	260	362	277	505
Resistance ⁴	Ω	ohms	4.53	6.50	5.22	7.50	2.01	9.65	2.58
Inductance ³	L	millihenries	0.808	1.39	1.64	2.9	0.78	4.08	1.06
Thermal Resistance ¹	R_{th}	°C/watt	2.75	2.00	2.23	1.58	1.50	1.25	1.26
Thermal Time Constant	T_{th}	minutes	30	30	30	35	35	40	40
Electrical Time Constant	T_{te}	milliseconds	0.178	0.21	0.31	0.39	0.39	0.42	0.41
Mechanical Time Constant	T_m	milliseconds	9.2	5.0	13.7	8.6	8.8	5.4	7.0
Rotor Inertia	J	lb-in-sec ²	0.000094	0.00016	0.00046	0.00082	0.00082	0.00117	0.00117
		oz-in ² (mass)	0.58	0.99	2.84	5.07	5.07	7.23	7.23
		kg-m ² x 10 ⁻⁶	10.62	18.07	51.97	92.65	92.65	132.19	132.19
Weight	#	pounds (kg)	1.1 (0.5)	1.6 (0.7)	2.6 (1.2)	3.5 (1.6)	3.5 (1.6)	4.4 (2.0)	4.4 (2.0)

Data listed is for SM motors alone. Drive specifications may change some values.

¹ @25°C ambient with 10 x 10 x 0.25 in. mounting plate, 90°C winding temperature. For 40°C ambient operation, reduce values by 12%.

³ ±30%, line-to-line, inductance bridge measurement method @ 1 kHz
⁴ ±10%, line-to-line, at 25°C

² With 500 ppr encoders. For 1,000 ppr encoders, derate to 6000 rpm.

Motor Specifications— Compumotor NeoMetric Series Servo Motors (70mm)

Parameter	Symbol	Units	N0701D	N0701F	N0702E	N0702F	N0703F	N0703G	N0704F	N0704G
			N0341D	N0341F	N0342E	N0342F	N0343F	N0343G	N0343F	N0344G
Stall Torque Continuous ^{1,4}	T_{CS}	lb-in	5.8	5.8	10.6	10.6	16.2	16.2	20.0	20.0
		N-m	0.65	0.65	1.19	1.19	1.83	1.83	2.26	2.26
Stall Current Continuous ^{1,2}	I_{CS}	amps-rms	2.92	4.56	3.36	4.67	4.59	6.38	4.73	6.57
Rated Speed	ω_r	rpm	4850	7500	3025	4380	2825	4050	2365	3390
		rps	80.8	125	50.4	73	47.1	67.5	39.4	56.5
Peak Torque ¹	T_{pk}	lb-in	17.3	17.3	32.0	32.0	48.6	48.6	60.0	60.0
		N-m	1.95	1.95	3.62	3.62	5.49	5.49	6.78	6.78
Peak Current, rms ^{1,6}	I_{pk}	amperes	8.8	13.7	10.0	14.0	13.7	19.1	14.2	19.7
Torque @ Rated Speed ¹	T_C	lb-in	4.6	4.6	8.6	8.6	13.0	13.0	15.8	15.8
		N-m	0.52	0.52	0.97	0.97	1.47	1.47	1.79	1.79
Rated Power-Output Shaft ¹	P_o	watts	265	415	309	447	435	624	442	634
Voltage Constant ^{3,4}	K_b	volts/radian/sec	0.221	0.14	0.353	0.253	0.392	0.282	0.468	0.338
Voltage Constant ^{3,4}	K_e	volts/KRPM	23.11	14.67	36.97	26.52	40.99	29.54	49.02	35.36
Torque Constant ^{3,4}	K_t	lb-in/amp rms	1.95	1.24	3.12	2.24	3.46	2.50	4.14	2.99
Resistance ³	R	ohms	5.52	2.27	5.22	2.7	3.36	1.74	3.47	1.80
Inductance ⁵	L	millihenries	12.98	5.23	15.86	8.16	12.13	6.30	14.50	7.55
Thermal Resistance ¹	R_{th}	°C/watt	1.44	1.44	1.15	1.15	0.96	0.96	0.87	0.87
Motor Constant	K_m	lb-in/ \sqrt{watt}	0.83	0.83	1.37	1.36	1.89	1.89	2.23	2.23
Viscous Damping	B	lb-in/Krpm	0.044	0.044	0.05	0.05	0.0563	0.0563	0.0625	0.0625
Torque-Static Friction	T_f	oz. in.	1.4	1.4	2.1	2.1	2.8	2.8	3.5	3.5
Thermal Time Constant	τ_{th}	minutes	45	45	45	45	45	45	45	45
Electrical Time Constant	τ_e	milliseconds	2.35	2.35	3.03	3.03	3.61	3.61	4.19	4.19
Mechanical Time Constant	τ_m	milliseconds	1.3	1.3	0.77	0.77	0.54	0.54	0.52	0.52
Rotor Inertia	J	lb-in-sec ²	0.000106	0.000106	0.000173	0.000173	0.000240	0.000240	0.000307	0.000307
Weight	#	pounds	3.54	3.54	4.53	4.53	6.04	6.04	7.28	7.28
Winding Class			H	H	H	H	H	H	H	H

¹ @ 25°C ambient with 10 x 10 x 0.25 in. mounting plate, 90°C encoder temperature.

² RMS current, line-to-line, six state commutation.

³ +/- 10% line-to-line.

⁴ Peak value.

⁵ +/- 30% line-to-line, inductance bridge measurement @ 1KHz.

⁶ Peak current for 2 seconds maximum with initial winding temperature of 40°C.

All specifications are subject to engineering change.

Motor Specifications—

Compumotor NeoMetric Series Servo Motors (92mm)

Parameter	Symbol	Units	N0921F	N0921G	N0922G
Stall Torque Continuous ^{1,4}	T_{CS}	lb-in	16	16	31
		N-m	1.81	1.81	3.50
Stall Current Continuous ^{1,2}	I_{CS}	amps-rms	4.16	5.76	6.17
Rated Speed	ω_r	rpm	2500	3575	1975
		rps	41.7	59.6	32.9
Peak Torque ¹	T_{pk}	lb-in	48	48	93
		N-m	5.42	5.42	10.51
Peak Current, rms ^{1,6}	I_{pk}	amperes	12.5	17.3	18.5
Torque @ Rated Speed ¹	T_C	lb-in	12.9	12.9	24.6
		N-m	1.46	1.46	2.78
Rated Power-Output Shaft ¹	P_o	watts	383	548	578
Voltage Constant ^{3,4}	K_b	volts/radian/sec	0.427	0.309	0.556
Voltage Constant ^{3,4}	K_e	volts/KRPM	44.66	32.37	58.18
Torque Constant ^{3,4}	K_t	lb-in/amp rms	3.84	2.78	5.0
Resistance ³	R	ohms	3.72	1.94	2.32
Inductance ⁵	L	millihenries	17.11	8.99	14.72
Thermal Resistance ¹	R_{th}	°C/watt	1.06	1.06	0.77
Motor Constant	K_m	lb-in/ \sqrt{watt}	1.96	2.00	3.29
Viscous Damping	B	lb-in/Krpm	0.075	0.075	0.0875
Torque-Static Friction	T_f	oz. in.	4	4	6
Thermal Time Constant	τ_{th}	minutes	60	60	60
Electrical Time Constant	τ_e	milliseconds	4.6	4.6	6.4
Mechanical Time Constant	τ_m	milliseconds	1.13	1.13	0.64
Rotor Inertia	J	lb-in-sec ²	0.000363	0.000363	0.000623
Weight	#	pounds	8.1	8.1	11.7
Winding Class			H	H	H

¹ @25°C ambient with 10 x 10 x 0.25 in. mounting plate, 90°C encoder temperature.

² RMS current, line-to-line, six state commutation.

³ +/- 10% line-to-line.

⁴ Peak value.

⁵ +/- 30% line-to-line, inductance bridge measurement @ 1KHz.

⁶ Peak current for 2 seconds maximum with initial winding temperature of 40°C.

All specifications are subject to engineering change.

Speed/Torque Curves

Note: Curves are based on 120VAC line, nominal motor K_t , and K_e . Actual values may vary $\pm 10\%$. Line voltage directly limits maximum speed.

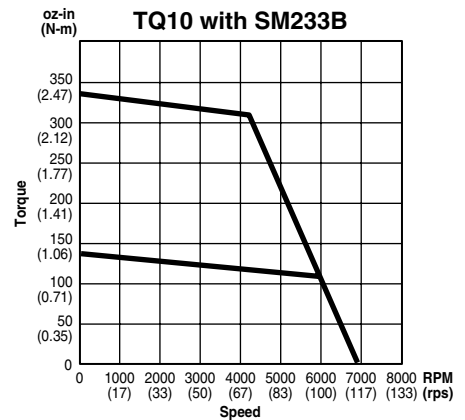
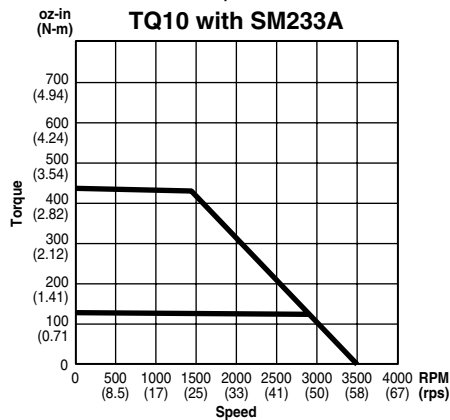
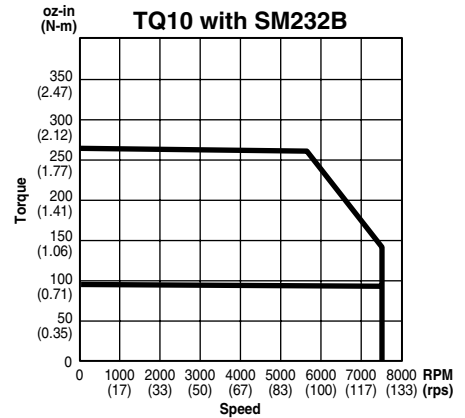
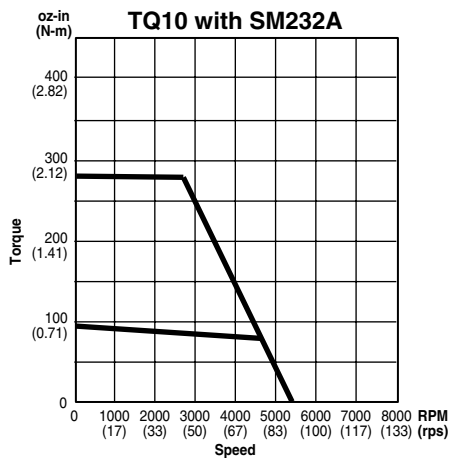
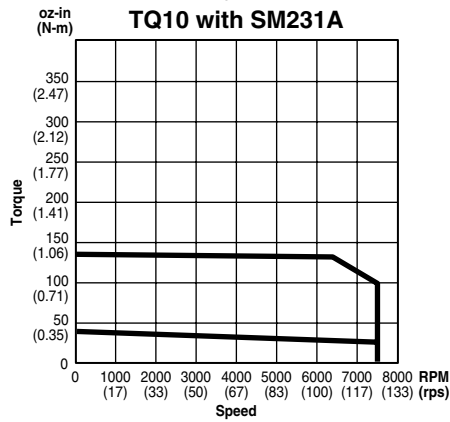
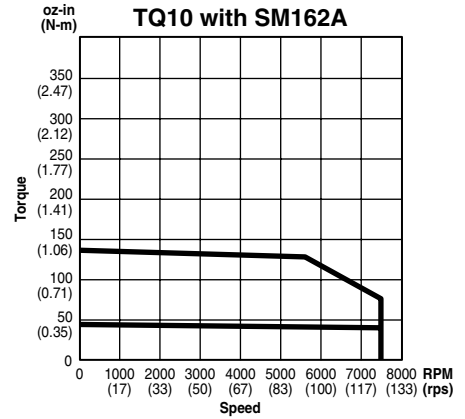
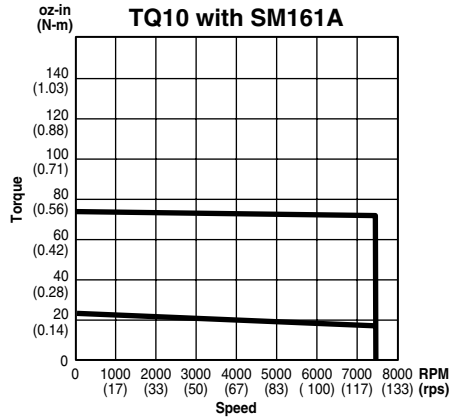

Speed/Torque Curves

Note: Curves are based on 120VAC line, nominal motor K_v , and K_t . Actual values may vary $\pm 10\%$. Line voltage directly limits maximum speed.

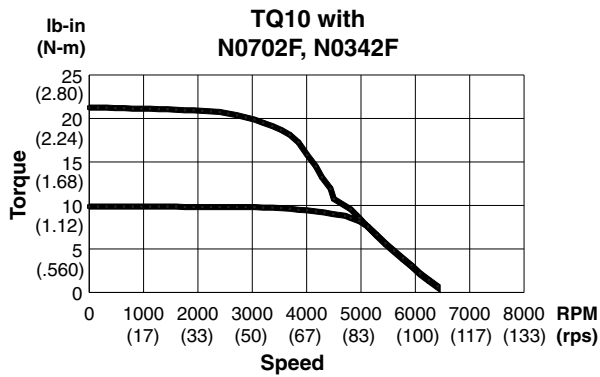
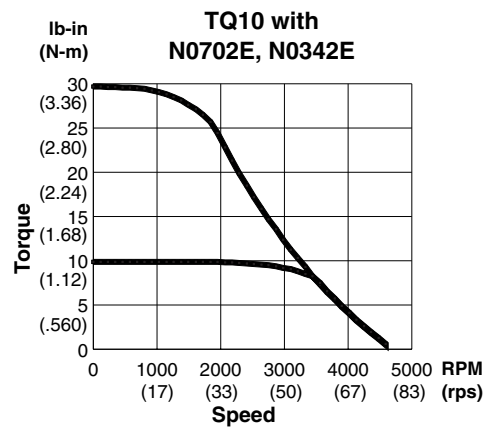
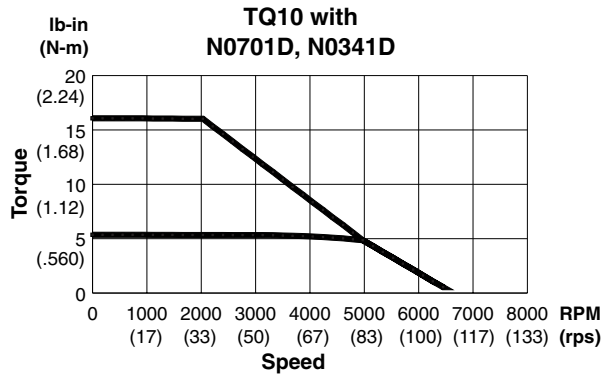

Motor Dimensions—Compumotor SM Series, Size 16

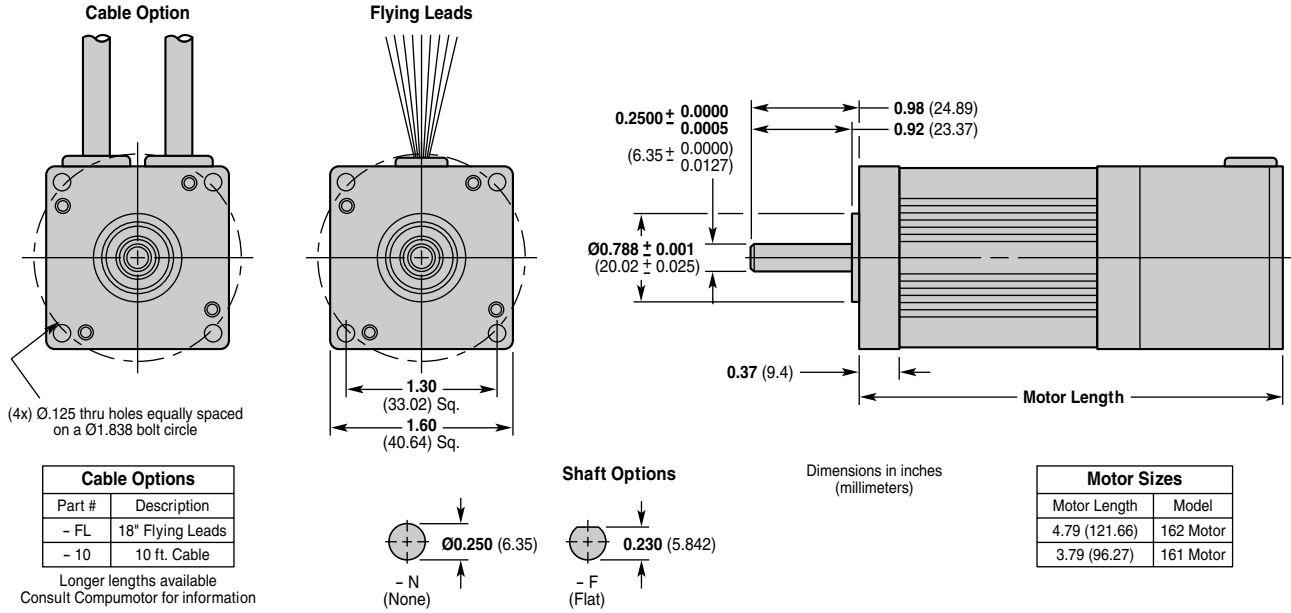

Motor Dimensions—Compumotor SM Series, Size 23

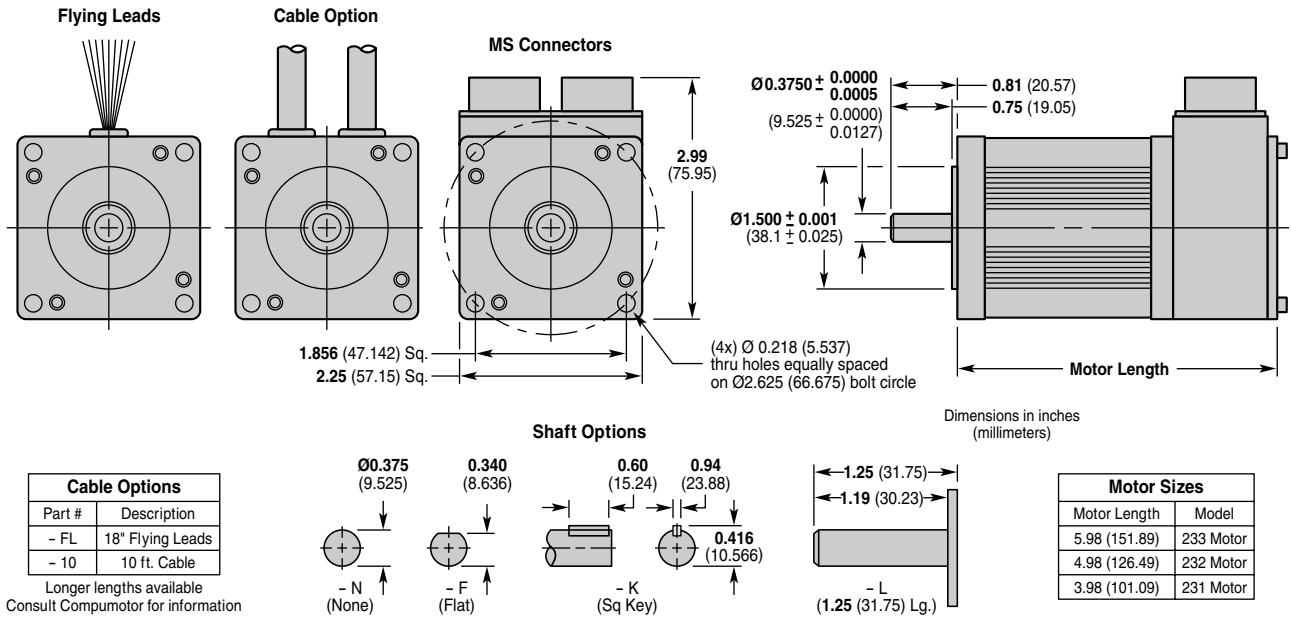

Motor Dimensions—Compumotor NeoMetric Series, Size 70

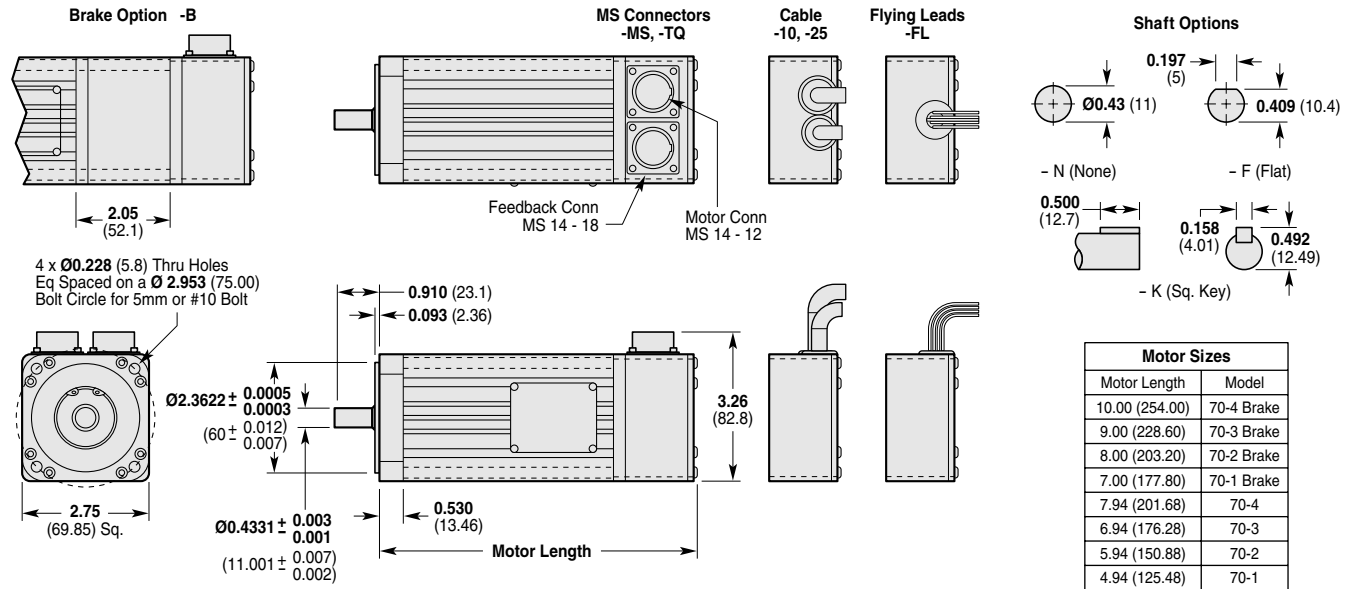

Motor Dimensions—Compumotor NeoMetric Series, Size 34

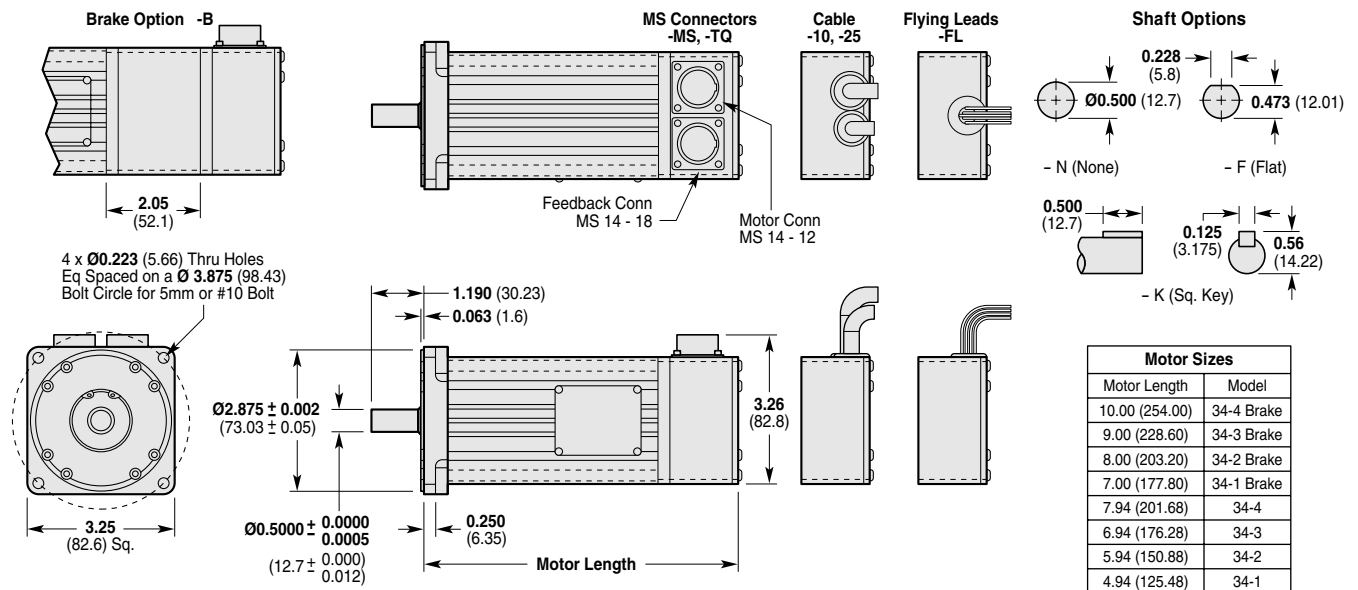

Motor Dimensions—Compumotor NeoMetric Series, Size 92

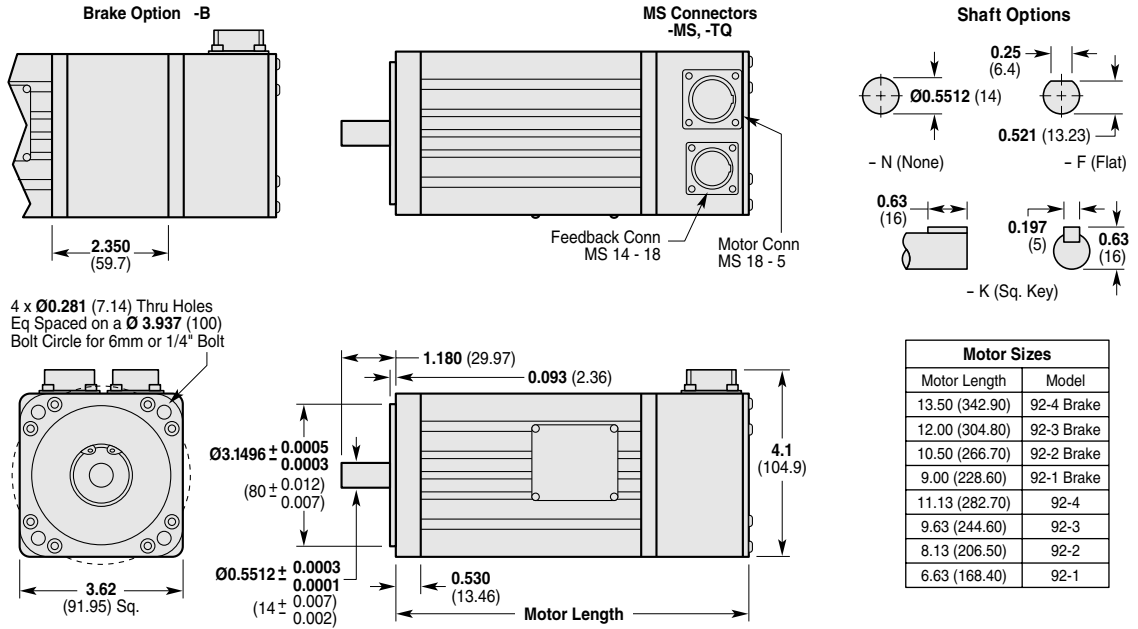

Encoder Specifications – Compumotor SM & NeoMetric Series Motors

Parameter	Value
Performance	
Accuracy	± 2 min of arc
Electrical	
Input Power	5VDC $\pm 5\%$ @ 135 mA
Operating Frequency	100 kHz maximum (pre-quadrature)
Output Device	26LS31
Sink/Source, nominal	20 mA
Suggested User Interface	26LS32

Motor Part Numbering System— Compumotor SM Servo Motor

The diagram below illustrates the part numbering system for Compumotor SM Series servo motors.

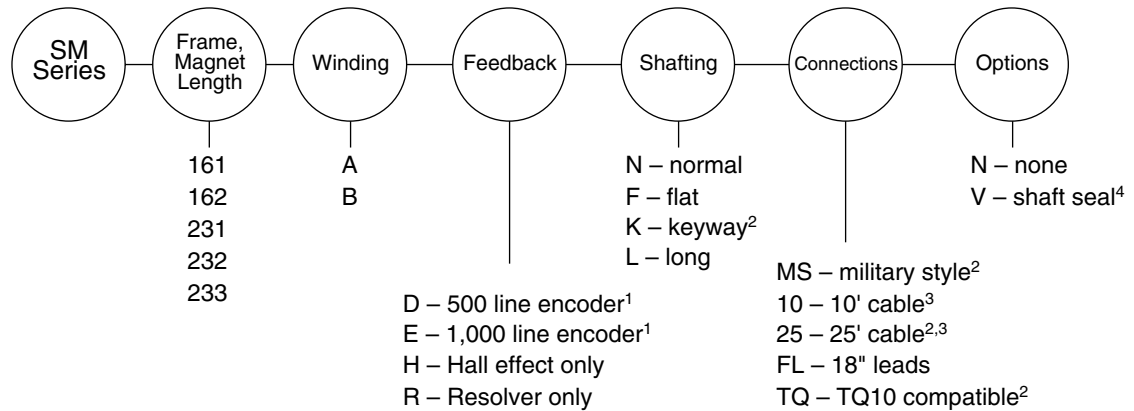

¹ includes Hall effect sensors
² not available on size 16 motors
³ cable is hardwired to motor
⁴ size 23 with MS or TQ connectors–IP65

Example: SM-231AE-NTQN = 23 Frame, 1" magnet, A winding, 1,000 line Encoder, Normal Shaft, TQ10 compatible, No options

Motor Part Numbering System— Compumotor NeoMetric Series Servo Motor

The diagram below illustrates the part numbering system for Compumotor NeoMetric Series servo motors.

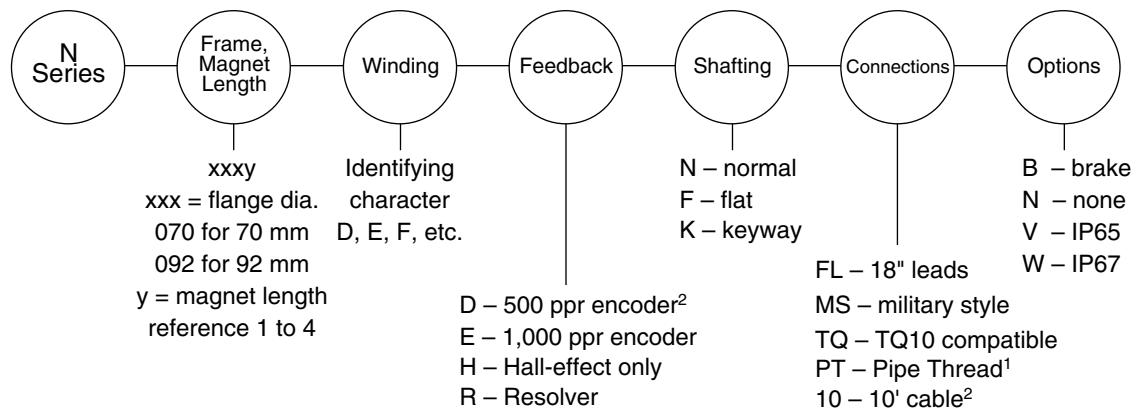

¹ 92 mm motors only
² 70 mm motors only

Example: N0702EE-KMSN