

CHAPTER ②

Getting Started

Chapter Objectives

The information in this chapter will enable you to:

- Verify that each component of your system has been delivered safely
- Become familiar with the system components and their interrelationships
- Ensure that each component functions properly by bench testing

What You Should Have

Inspect the SX upon receipt for obvious damage to its shipping container. Report any such damage to the shipping company. Parker Compumotor cannot be held responsible for damage incurred in shipment. The following items should be present and in good condition.

Description	Part Number
S Series Fan Kit	SFK***
Power Cable (SX 8 has 2 cables)	44-000054-01
SX or SXF Indexer/Drive	SX6/SXF6 or SX8/SXF8
SX Indexer/Drive User Guide	88-011850-01
SX Software Reference Guide	88-011871-01
Motor	Variety of sizes available**
Mounting Screws (2)	51-006037-01
Mounting Brackets (2)	53-006007-01

*The SX8 Drive includes a fan

**Refer to the following tables for specific motor sizes

***Optional Equipment

High and Low Power Drives

You should verify which type of SX you have before proceeding with this chapter. The high-power version of the drive (**SX8**) provides bipolar 0 - 8 amps/phase (up to 1,900 oz-in). The low-power version of the drive (**SX6**) provides bipolar 0 - 6 amps/phase (up to 400 oz-in). You can determine which drive you have by checking the label on the side of the drive. The label identifies the unit as **SX8 DRIVE** (SX106) or **SX6 DRIVE** (SX57 & SX83). You must be aware of the drive's type to set the motor current correctly (using DIP switches). There are different DIP switch settings for the two drive types.

Quick Test

This section will show you how to set the SX's DIP switches and wire the unit to quickly ensure that your system is operating properly. Detailed installation instructions are provided in *Chapter 3, Installation*. You will need the following tools to complete these steps:

- A phillips-head screw driver (to move mounting brackets)
- A small flat screw driver (to adjust DIP switches and make connections)

CAUTION

Never adjust the DIP switches with a pencil. Lead from the pencil may contaminate the SX.

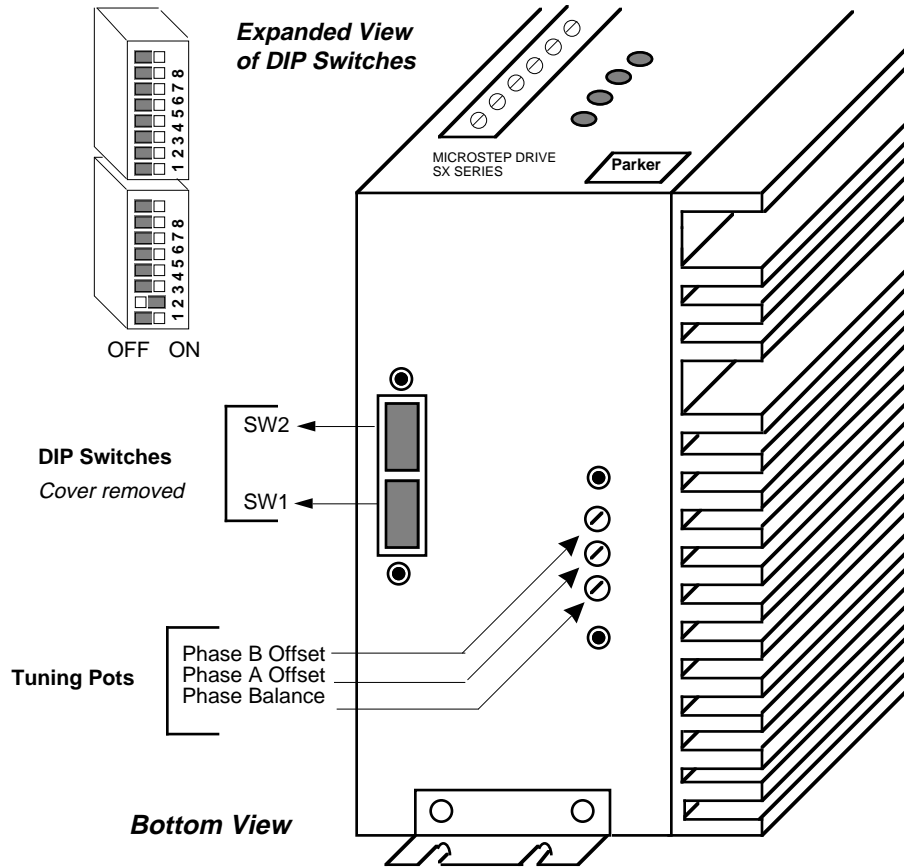

DIP Switch & Tuning Pot Locations

WARNING

Never attempt to change DIP switch settings while power is being applied to the unit.

① Set DIP Switches

The SX has two sets of DIP switches. Each set of DIP switches has eight individual switches. The first set of switches will be referred to as **SW1** and the second set as **SW2**. The individual switch will be preceded by the # symbol. Hence, the third switch on **SW1** will be referred to as **SW1-#3**, while the third switch on **SW2** will be referred to as **SW2-#3**.

The first thing that you must do is set the motor current on the SX to match the motor that you are using. Use the directions below to set the DIP switches for your motor. (*Motor Drive combinations are configured at the factory for the proper current settings.*)

- ① Be sure that power is not applied to the unit.
- ② Remove the panel that covers the DIP switches. (Refer to earlier figure.)
- ③ Set the motor current for your Compumotor motor using the following tables. **SW1-#1** thru **SW1-#6** control motor current (refer to the previous figure for the location of **SW1**). Make the required adjustments to match the drive and motor types that you are using.

The following current tables are for S/SX Motors only.

Motor Size	Current	SW1-#1	SW1-#2	SW1-#3	SW1-#4	SW1-#5	SW1-#6
S57-51S	1.18	off	off	on	on	off	off
S57-51P	2.28	off	on	on	off	off	off
S57-83S	1.52	off	on	off	off	off	off
S57-83P	3.09	on	off	off	off	off	off
S57-102S	1.71	off	on	off	off	on	off
S57-102P	3.47	on	off	off	on	off	off
S83-62S	2.19	off	on	off	on	on	on
S83-62P	4.42	on	off	on	on	on	off
S83-93S	2.85	off	on	on	on	on	off
S83-93P	5.62	on	on	on	off	on	on
S83-135S	3.47	on	off	off	on	off	off
S83-135P	6.00	on	on	on	on	on	on

S: Series Configuration P: Parallel Configuration

Setting SX6 Motor Current (Compumotor Motors)

Motor Size	Current	SW1-#1	SW1-#2	SW1-#3	SW1-#4	SW1-#5	SW1-#6
S106-178S	6.02	on	off	on	on	on	on
S106-178P	8.0	on	on	on	on	on	on
S106-205S	3.55	off	on	on	on	off	off
S106-205P	6.99	on	on	off	on	on	on
S106-250S	6.23	on	on	off	off	off	on
S106-250P	8.0	on	on	on	on	on	on

S: Series Configuration P: Parallel Configuration

Setting SX8 Motor Current (Compumotor Motors)

The previous tables show motor current settings for series and parallel motor configurations. Refer to *Chapter 6, Hardware Reference* for specific motor configuration instructions. **Compumotor ships all SX systems in series configurations.**

If you use a non-Compumotor motor, special precautions and instructions are required. Read the instructions in Chapter 6, Hardware Reference for non-Compumotor motors thoroughly before attempting to set the motor current or wire your motor.

- ④ Turn **SW2-#8** on to enable the Automatic Test function. This function rotates the motor in an Alternating mode approximately 6 revolutions at 1 rps (12 inches at 2 ips if an L20 linear motor is used) as soon as power is applied.
- ⑤ After you have properly set motor current (**SW1-#1** thru **SW1-#6**) and the Automatic Test function (**SW2-#8**), screw the plate that covers the DIP switches back onto the drive. **Do not change any other DIP switch settings.**

② Attach the Motor

WARNING

POWER MUST BE OFF before cabling the drive. Lethal voltages are present inside the drive and on its screw terminals.

The SX motor is pre-wired in series. Plug the pre-wired motor cable into the motor connector on the drive (refer to the following figure). If you use a non-Compumotor motor, refer to *Chapter 6, Hardware Reference* for instructions on wiring the motor to the drive. **Do not connect the motor to the load at this time.**

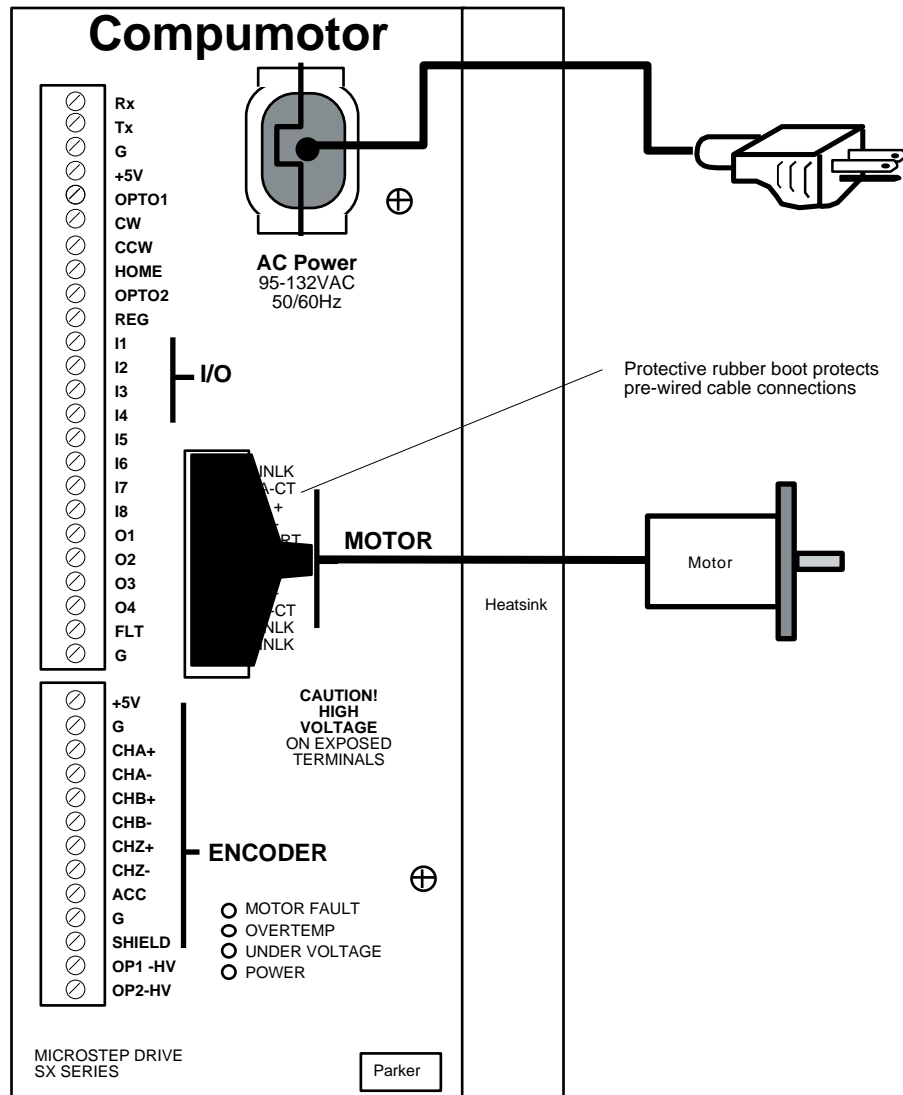

Test Configuration (S6 Drive shown)

③ Apply Power

- ① Plug the molded AC cable into the power connector on the drive (refer to the previous figure).
- ② Plug the other end of the cable into a 115VAC power source. **If you are using the SX8 Drive (high power), you must also plug in the fan's power cable to 115VAC. The fan must be on when power is applied to the drive.** The motor should rotate in an Alternating mode approximately 6 revolutions at 1 rps. The **green** Power LED should be on.
- ③ **To stop the motor, you must unplug the power cable from the power source. The motor may continue to run for a few seconds after you remove power.**

The successful completion of this test indicates that the amplifier, motor, and microprocessor are operating properly.

Indexer Test

This section will show you how to quickly test the RS-232C Indexer to assure proper operation.

With no power applied to the drive, perform the following steps to test the communications. The default motor resolution setting for the SX is set to 25,000 steps/rev.

Step ①

Remove the panel that covers the DIP switches. Turn DIP switch **SW2-#8** (off) to disable the Automatic Test function. Ensure that switches **SW2-#1** through **SW2-#4** are **off**. **Do not change any other DIP switch settings.** Screw the panel back onto the drive.

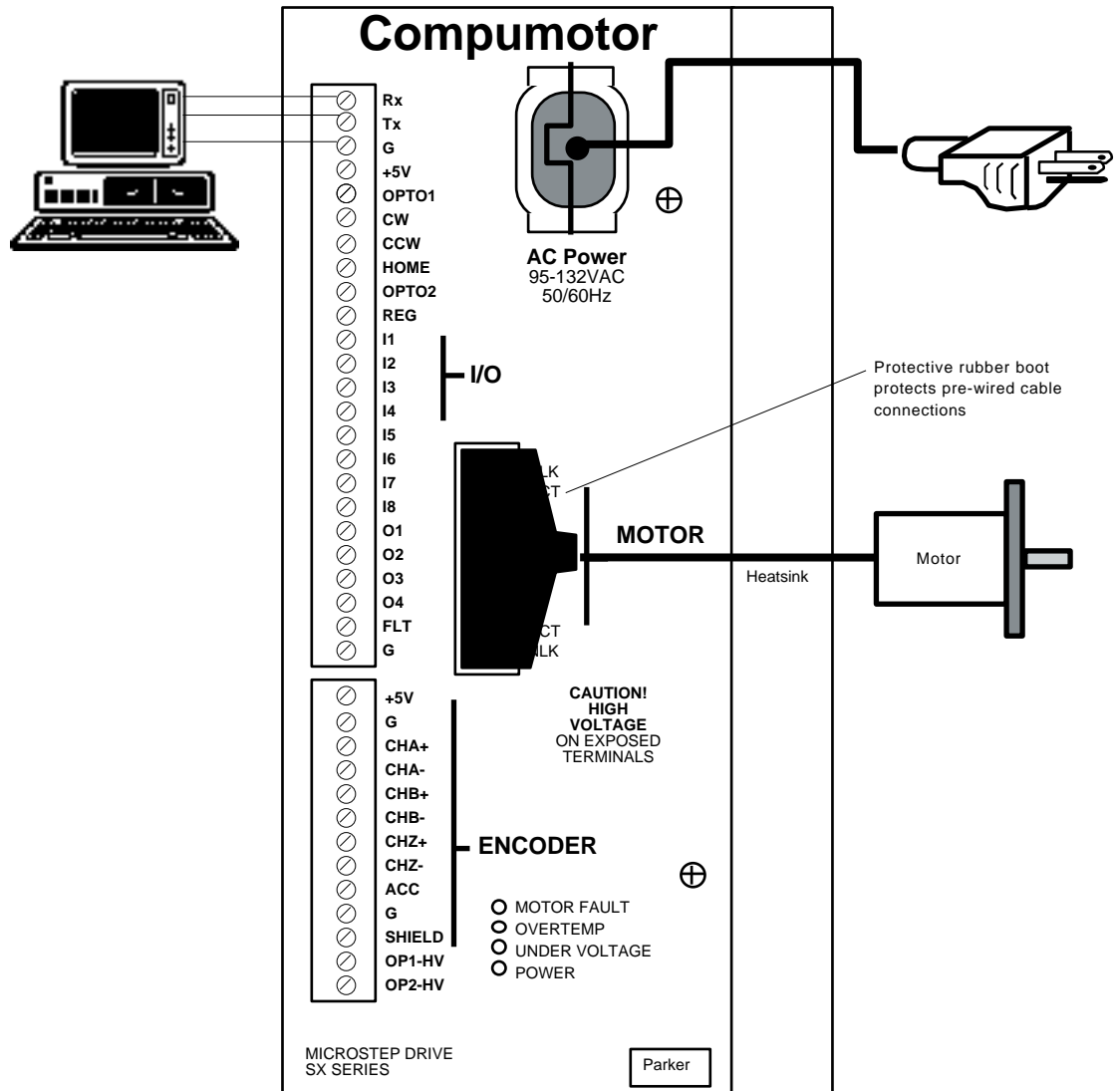

Test Configuration (S6 Drive shown)

A terminal emulator program or communications driver is required to establish communications with the SX. Contact your distributor for a copy of Compumotor's X-Ware if needed.

Step ② Connect a terminal to the RS-232C connector (I/O) using the **Rx** (receive), **Tx** (transmit), and **G** (ground) connections. The basic communications parameters are listed below:

- Baud Rate: 9600
- Data Bits: 8
- Stop Bits: 1
- Parity: None
- Full Duplex mode

Refer to the operations manual that accompanied your terminal for instructions on setting the communication parameters listed above. Chapter 3, Installation provides more RS-232C information for the SX.

Step ③

Apply power to all system components now. The following response should appear on the terminal:

***READY**

>

Step ④

You must now disable the hardware limits. Type the following command to disable the limits:

```
> LD3
```

To check the state of your hardware limits command, enter the following command:

```
> 1LD
```

You should receive the following response:

```
*3_No_Limits_Enabled
```

Step ⑤

Enter the following commands to move the motor 25,000 steps.

Command	Description
> A10	Sets acceleration to 10 rps ²
> AD10	Sets deceleration to 10 rps ²
> V1	Sets velocity to 1 rps
> D25000	Sets distance to 25,000 steps
> G	Initiates motion

Since the default drive resolution is 25,000 steps/rev, the motor should have moved 25000 steps or 1 revolution.

This completes the basic configuration tests. The successful completion of this test means that you wired the motor, terminal (optional), and power connections correctly. The components of your system are functioning properly. If the motor does not move as commanded, enter the following command:

```
>1RSE
```

You should receive the following response:

```
*NO_ERRORS
```

If an error message flashes, correct the problem and repeat step 5.