

CE
PDS Type 2 Stepper Drive
User Guide
(PDS13-2 PDS15-2 PDS15-D-2)

For engineering assistance in Europe:
Parker Hannifin plc
Electromechanical Division - Digiplan
21 Balena Close
Poole, Dorset
England, BH17 7DX
Tel: 01202-699000
Fax: 01202-695750
E-mail: tech.help@digiplan.com

For engineering assistance in Germany
Parker Hannifin GmbH
Electromechanical Division - Hauser
P. O. Box: 77607-1720
Robert-Bosch-Str. 22
D-77656 Offenburg Germany
Tel: (0781) 509-0
Fax: (0781) 509-176

For engineering assistance in the U.S.:
Parker Hannifin Corporation
Compumotor Division
5500 Business Park Drive, Suite D
Rohnert Park CA 94928 USA
Tel: (800) 358-9070
Fax: (707) 584-3793
FaxBack System: (800) 936-6939
BBS: (707) 584-4059
E-mail: tech_help@cmotor.com

IMPORTANT INFORMATION FOR USERS

Installation and Operation of Digiplan Equipment

It is important that Digiplan motion control equipment is installed and operated in such a way that all applicable safety requirements are met. Note that it may be necessary for the complete installation to comply with the Low Voltage or Machinery Directives. It is your responsibility as an installer to ensure that you identify the relevant safety standards and comply with them; failure to do so may result in damage to equipment and personal injury. In particular, you should study the contents of this user guide carefully before installing or operating the equipment.

The installation, set-up, test and maintenance procedures given in this User Guide should only be carried out by competent personnel trained in the installation of electronic equipment. Such personnel should be aware of the potential electrical and mechanical hazards associated with mains-powered motion control equipment - please see the safety warning below. The individual or group having overall responsibility for this equipment must ensure that operators are adequately trained.

Under no circumstances will the suppliers of the equipment be liable for any incidental, consequential or special damages of any kind whatsoever, including but not limited to lost profits arising from or in any way connected with the use of the equipment or this user guide.



SAFETY WARNING

High-performance motion control equipment is capable of producing rapid movement and very high forces. Unexpected motion may occur especially during the development of controller programs. **KEEP WELL CLEAR** of any machinery driven by stepper or servo motors. Never touch it while it is in operation.

This product is sold as a motion control component to be installed in a complete system using good engineering practice. Care must be taken to ensure that the product is installed and used in a safe manner according to local safety laws and regulations. In particular, the product must be enclosed such that no part is accessible while power may be applied.

High voltages exist within enclosed units, on rack system backplanes (motherboards) and on transformer terminals. Operators must be denied access to these areas. Service personnel must keep clear of these areas when power is applied to the equipment.

If the equipment is used in any manner that does not conform to the instructions given in this user guide, then the protection provided by the equipment may be impaired.

The information in this user guide, including any apparatus, methods, techniques, and concepts described herein, are the proprietary property of Parker Digiplan or its licensors, and may not be copied, disclosed, or used for any purpose not expressly authorised by the owner thereof.

Since Digiplan constantly strives to improve all of its products, we reserve the right to modify equipment and user guides without prior notice. No part of this user guide may be reproduced in any form without the prior consent of Digiplan.

© **Digiplan Division of Parker Hannifin plc, 1998**
– **All Rights Reserved** –

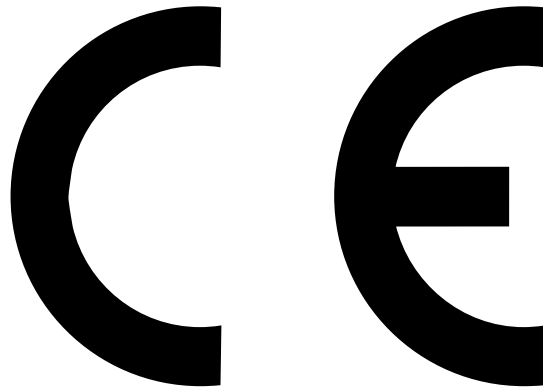

Product Type: PDS13-2, PDS15-2, PDS15-D-2

The above products are in compliance with the requirements of the following Directives, when installed in accordance with the instructions contained within this User Guide.

- **73/23/EEC Low Voltage Directive**
- **93/68/EEC CE Marking Directive**

The PDS Series of drives are sold as complex components to professional assemblers, as components they are not compliant with Electromagnetic Compatibility Directive 89/336/EEC. However, information is offered in this User Guide on how to install these drives in a manner most likely to minimise the effects of drive emissions and to maximise the immunity of drives from externally generated interference.

Contents

Contents.....	i
Section 1. INTRODUCTION.....	1
Section 2. SPECIFICATION.....	3
Section 3. INSTALLATION.....	7
Section 4. Setting Up.....	31
Section 5. Maintenance & Troubleshooting.....	35
Index.....	39

User Guide Change Summary

The following is a summary of the primary changes to this user guide since the last version was released. This user guide, version 1600.171.05, supersedes version 1600.171.04.

When a user guide is updated, the new or changed text is differentiated with a change bar in the outside margin (this paragraph is an example). If an entire section is changed, the change bar is located on the outside margin of the section title.

Major changes introduced at revision 05 are:

Clarification of motor wiring requirements

Corrections to the drive mounting hole dimensions (Figure 3-12)

Factory default setting of bit switch 3 has been changed to OFF

Warning symbols used on the PDS series of drives have the following meanings:



Refer to the accompanying documentation



Protective conductor terminal



Risk of electric shock



Alternating current



Hot surface



Frame or chassis terminal

Section 1. INTRODUCTION

Product Description

The PDS series of single-axis packaged ministep drives consists of the PDS13-2 & PDS15-2, with peak current ratings of 3A and 5A respectively. A further 5A version, known as the PDS15-D-2 is also available with a built-in regenerative dump circuit. PDS series drives are high-performance, MOSFET, chopper-regulated stepper drives designed for optimum performance in low and medium power applications. A recirculating chopper regulator improves operating efficiency, minimizes power consumption, and reduces motor and drive heating. They are powered Direct On-Line (DOL) from mains supplies of 110V to 240V (nominal) AC. An internal switch mode power supply is used, incorporating Power Factor Correction (PFC) to minimise distortion of the AC supply.

The PDS series of drives have 4 selectable resolutions between 400 steps/rev and 4000 steps/rev, set using the front panel switches.

Motor short-circuit protection is assured across and between phases and between any phase and earth. If a wiring fault occurs the drive fault LED will be lit up - see ***Maintenance and Troubleshooting***.

The drives are suitable for use with hybrid and permanent magnet stepping motors having 4, 6, or 8 leads.

The drives can be used as stand alone units with separate control inputs and motor connection/power inputs. An on-board clock can be used to control drive motion or an external step direction source can be used.

The step, direction and shutdown differential inputs are fully opto isolated for maximum noise immunity. The type 2 series of drives have improved input noise immunity compared with the PDS13 and PDS15/PDS15-D series. These noise immunity improvements may require minor connection changes (detailed in the Installation section) to make a type 2 drive a plug-in replacement for an existing PDS13 or PDS15/PDS15-D drive.

2 PDS SERIES DRIVE USER GUIDE

The system may be configured to allow the clock signal to be provided by the drive's internal clock source. Two separate programmable speeds are available. These are set by front panel pots marked "Fast" and "Slow", a third pot allows adjustment of the acceleration and deceleration times. The speed control potentiometers may be mounted remotely via the front panel D-type connector.

The internal clock source signal is brought out to the drive control connector for monitoring purposes.

The drive and integral power supply are contained in one compact enclosure, cooled by natural convection. Wall or panel vertical mounting is recommended to allow access to the front panel connectors and controls for service personnel use only.

Section 2. SPECIFICATION

PDS Series Drive Specifications

Parameter	Value
Amplifiers	
Type	MOSFET Chopper
Motor resolution	400, 1000, 2000 and 4000 steps/rev (user-selectable)
Protection Short circuit	Phase-to-phase, across phases and phase to ground
Peak output current	3A/phase (PDS13-2), 5A/phase (PDS15-2) - switch reduceable
Standby current reduction	To 80% or 50% of programmed peak value after 100ms (switch-selected)
Maximum stepping rate	200kHz @ 4000 steps/rev (using differential inputs) 50kHz @ 1000, 2000 or 4000 steps/rev (using Aux clock input)
Nominal chopping frequency	20kHz
Command Interface	
STEP/DIR/SHUTDOWN Configured as differential opto-isolated inputs	
Drive requirements	3 to 5V differential
max input current	21mA
min input current	10mA
STEP	
Minimum pulse width	1 μ s
Max. frequency	200kHz
Drive clocks on transition to state ()	STEP+(high) STEP-(low)
DIR	
Shaft reversal on transition	DIR+, DIR-
AUX CLK/DIR Configured as single-ended, non-isolated inputs	
Drive requirements	Low <+2V, High 10-12V, (4K7 pull-up to +12V built-in)

Table 2-1. PDS Series Drive Specifications

4 PDS SERIES DRIVE USER GUIDE

Parameter	Value
Command Interface continued	
AUX CLK Minimum pulse width Max. frequency	8 μ s 50kHz
AUX DIR Shaft reversal on transition	Change of logic state
SHUTDOWN Motor shutdown on transition to state ()	SHUTDOWN+(high) SHUTDOWN-(low)
Fault	Unassigned NPN transistor (see figure 3) Active Low (transistor switched to 0V) +1.0V max. @ 5mA max. High (transistor off) +24V max.
Internal clock out	Open collector NPN transistor - emitter connected to drive 0V (GND)
Power up reset time	1 - 2 secs
AC Power input	
Drive supply voltage Supply frequency range Power factor	95V to 264V AC (absolute limits) 47 to 63Hz Better than 0.9 over input voltage range and output power range
Input current PDS13-2 PDS15-2 Recommended supply protection	2A rms max 3A rms max 3A MCB type 'C' characteristics or in-line fuse (3A TL HB)
Fuse Values	
PDS13 mains input (FS2 & FS3) PDS 15 mains input (FS2 & FS3) Motor HV fuse FS1 Dump PCB fuse FS1 (if fitted)	2A TL HB (6.3 x 32 mm) 3.15A TL HB (6.3 x 32 mm) 5A QA HB (5 x 20mm) 500mA TL LB (5 x 20mm)
Internal Clock Source	
Speed range Fast Slow Acceleration/deceleration range Internal clock out signal	1 rps - 50 rps 0.05 rps - 2.0 rps 20.0 - 500 rps ² 1 μ s pulse width (fixed)
Output current range	
PDS13-2 PDS15-2 Standby reduction	0.9A - 3A (300mA steps) 2.5A - 5A (350mA steps) 50% or 80%

Table 2-1. PDS Series Drive Specifications (Continued)

Parameter	Value
Environmental	
Drive dimensions	Height 250mm(9.8in), Width 50mm (2in), Depth 190mm (7.5in)
Weight	1.8Kgms (4lbs)
Operating temperature	0° - 40°C (32° - 104°F)
Ingress protection	IP20
Relative humidity	0-95% non-condensing
Pollution degree	2
Max. power dissipation of drive unit	
PDS13-2	18Watts
PDS15-2	28Watts
PDS15-D-2	43Watts
Motors	
Type	2-Phase hybrid or permanent magnet (normally 1.8°)
Number of leads	4, 6, or 8 (5 lead not suitable)
Minimum Motor Inductance	1mH
Optimum Inductance range	1mH-10mH
Power/Motor connection	refer to <i>Installation</i>

Table 2-1. PDS Series Drive Specifications (Continued)

Pin	Name	I/O	Min. on State Current	Max. Current	Nominal Voltage	Signal Levels	Comments
1 14	STEP+ STEP-	I	10mA	21mA	5V	TTL	note 1, 2, 4
2 15	DIRECTION+ DIRECTION-	I	10mA	21mA	5V	TTL	note 1, 2
6	Slow Adjust	I	-	20mA	12V	-	-
7	Fast Adjust	I	-	20mA	12V	-	-
9 21	Fault+ Fault-	O	-	5mA (at 1.0V)	24V	Unassigned transistor 26V max.	Active Low under fault condition note 3
12	Slow Run	I	-	2.5mA	12V	Low <+2V High = O/C	Active low
13	Fast Run	I	-	2.5mA	12V	Low <+2V High = O/C	Active low
16 17	Shutdown+ Shutdown-	I	10mA	21mA	5V	TTL	note 2
19	Adjust Common	O	-	20mA	12V	-	-

Table 2-2. Control I/O Signal Specification

Pin	Name	I/O	Min. on State Current	Max. Current	Nominal Voltage	Signal Levels	Comments
20	Internal clock out	O	-	15mA	24V	Open collector Low <250mV @ I _C 10mA	Active low
23	Aux Clock In	I	-	2.5mA	12V	Low <+2V High = O/C	Active low note 2, 5
24	Aux Direction In	I	-	2.5mA	12V	Low <+2V High = O/C	note 2, 6
25	GND	I/O	-	-	-	-	Signal return

Table 2-2. Control I/O Signal Specification (Continued)

- note 1 Do not change state of 'DIRECTION+' and 'DIRECTION-' inputs within 2.5μs of STEP transition to STEP+ high, STEP- low.
- note 2 See Figure 10 for input circuit.
- note 3 See Figure 7 for output circuit.
- note 4 Minimum pulse width 1μs, maximum frequency 200kHz.
- note 5 Minimum pulse width 8μs, maximum frequency 50kHz.
- note 6 Do not change the state of 'AUX DIRECTION' within 8μs of 'AUX CLOCK' transition from high to low.
-

Section 3. INSTALLATION

Installation Options

PDS drives must be installed by competent personnel familiar with the installation, commissioning and operation of motion control equipment. In the final application the equipment must be enclosed to prevent the operator coming into contact with any high voltages. This includes the drive and motor terminations.

The drives are not EMC compliant, they are sold as a complex component for professional assemblers of motion control systems. Where a system is not required to conform to the European EMC directive the installation procedure described in this Section may be followed. Systems which are to conform to the European EMC directive should be assembled using these procedures and additionally the EMC specific installation recommendations, described at the end of this Section. Digiplan cannot guarantee EMC compliance.

The drive must be installed in an enclosure to protect it from atmospheric contaminants such as oil, moisture, dirt, etc. No operator access should be allowed to the drive while it has AC power applied. Metal equipment cabinets are ideally suited for siting the equipment since they can provide operator protection, EMC screening and can be fitted with interlocks arranged to remove all AC power when the cabinet door is open.

Provision must be made within the installation to contain the spread of fire by the fitting of a flame barrier, as defined in the LVD enclosure requirements. In many applications this requirement will be met simply by installing the drive within a cabinet fitted with a solid metal base. If the cabinet base is ventilated a flame barrier will be required that conforms with the baffle dimensions defined in the European Standard EN 61010-1.

Power Connections

Input power is taken directly from AC supplies via the front panel mounted IEC 3-way mains inlet socket. A power cord is supplied with the drive. Ensure that the drive is reliably earthed. Any mains wiring should have an insulation rating of at least 1350V (use approved mains cable of at least 0.75mm² CSA), and should be kept separate from the motor and signal wiring.

Wiring Guidelines

Proper grounding of electrical equipment is essential to ensure the safety of personnel and to reduce the effects of electrical noise due to electromagnetic interference (EMI). All Digiplan equipment should be properly grounded.

In general, all components and enclosures must be connected to earth ground to provide a low impedance path for ground fault or noise-induced currents. All earth ground connections must be continuous and permanent. A central earth stud is recommended.

Motor Selection

Usually optimum performance will be obtained when the current rating of the motor is between 1 and 1.5 times the drive rating (refer to specification).

For maximum high speed torque a motor rating of 7.5A peak should be used with the PDS15-2, 4.5A with the PDS13-2. The drives can be derated to accommodate motors with lower current ratings however, the high speed torque will be reduced.

Do not use a drive setting which gives an output current greater than the motor rating.

With 4 lead motors the bipolar rating is quoted and this should match the criteria stated above.

With 6 lead motors the unipolar rating is quoted, but for best performance with the PDS Drives the centre tap of each winding should be left unconnected and the connections made between the winding ends. This will give a bipolar rating 70% of the quoted motor unipolar rating.

With 8 lead motors the bipolar rating of the motor, which is normally quoted refers to a parallel winding connection. With the windings connected in series the current rating of the motor connection will be 50% that of the bipolar rating, and the motor will give improved low-speed torque, but reduced high-speed torque.

Regenerative Power Dump Option

Applications which involve rapid deceleration of high-inertia loads may require that the drive is fitted with a power dissipation circuit. The PDS15-D-2 has the same electrical specification as the PDS15-2 but incorporates a power dump with a continuous rating of 15 watts (170 watts peak). You will need the PDS15-D-2 in the following situation:

Metric formula - if the deceleration time $t < \{J\omega^2 - 0.1\}$

where t is the deceleration time in seconds

J is the total system inertia in Kg-m²

ω is the maximum speed in revolutions per second

Imperial formula - if the deceleration time $t < \{0.02J\omega^2 - 100\}$

where t is the deceleration time in milliseconds

J is the total system inertia in oz-in²

ω is the maximum speed in revolutions per second

If the expression in brackets is negative, the power dump option is not required. This option is strongly recommended for size 42 (106) motors.

Note that a program to calculate if a power dump is required is available from Compumotor and Digiplan Technical Support departments (Windows 3.1 required). This program is also available on Compumotor's Bulletin Board Service (see front cover for number).

Long Motor Leads

Using a motor with long leads will cause the cabling resistance to become significant when compared to the resistance of the motor.

The DC volt drop of the cable and motor connection when measured at the drive, should not exceed 5 volts in order to limit power dissipation in the drive and maintain maximum system performance. See **Motor Cables** in the **EMC Installation** sub-section.

Motor Connections

Once you have determined the motor's wiring configuration, connect the motor leads to the connector marked "MOTOR" on the front panel.

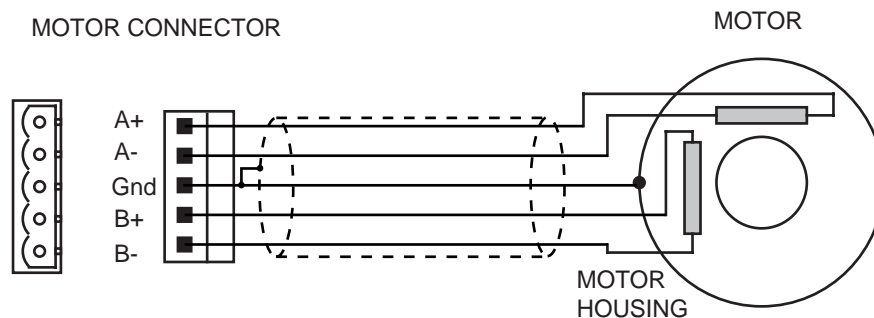

To reverse motor rotation relative to the direction input, interchange connections to A+ and A-.

Figure 3-1. PDS Drive Motor Connections

Motor Insulation

Motor insulation must be rated to withstanding voltages of at least 500V.

Motor Cable

The recommended gauge for PDS drives is 1mm². Use a cable containing five conductors plus the braided screen, the fifth (green) wire being used to provide an earth return to the drive. Note that the motor body should be directly connected to earth: do not use the 'Gnd' pin of the motor connector. The temperature rating of the cable must be greater than or equal to the motor case temperature and should be at least 80°C.

The cable used must have an insulation rating of at least 350V. That is, rated to withstand a test voltage of 350V for 1 minute. Note: the QM motor is supplied with a motor cable having a working voltage of 300V which is tested using a voltage in excess of 1000V for 1 minute.

Motor Earth

The motor body must be reliably earthed. The earth pin on the 5-way plug and socket motor connector is not an appropriate earthing point for the motor safety earth. A separate safety earth connection must be made to the motor's case as shown in Figure 3-2. Make sure a good electrical contact is made to the motor body - if necessary removing any paint from the contact area.

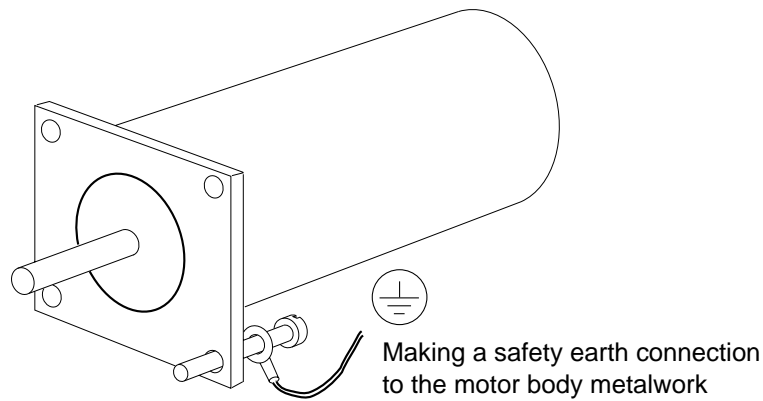

Figure 3-2. Motor Safety Earth (ground) Connection

WARNING

The case of a motor can become very hot. Precautions may need to be taken to prevent operator contact.

Drive Connections to ‘S’ or ‘QM’ Motors

Compumotor ‘S’ series and ‘QM’ series motors are electrically identical. In the case of 23 and 34 (57 and 83) frame sizes, the motors are constructed with an 8 core cable to allow you to select either a series or parallel wiring configuration.

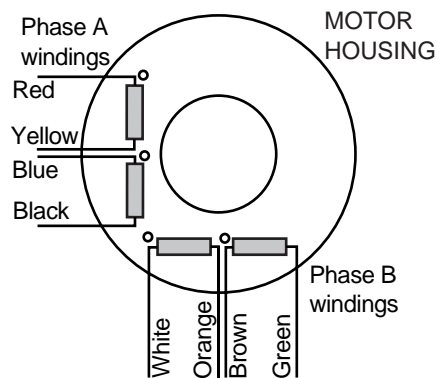

Figure 3-3. 8-Lead Motor Winding Colour Code for S or QM Motors

The 42 (106) frame size motors are constructed with a 4 core motor cable to connect to the drive - these motors can be configured by removing the rear cover plate and rewiring at the screw terminals. The following diagrams illustrate the connection methods for these motors.

QM106-178/S106-178 Series and Parallel Connections

This motor is pre-wired in series. If you remove the motor's back panel, access is provided to re-wire the motor in parallel.

The motor wiring colour code is:

<u>Motor Terminal</u>	<u>Wire Colour</u>	<u>Drive Terminal</u>
1	Red	A+
3	Black	A-
5	Green	B+
4	White	B-
Body	Bare (Screen)	Gnd

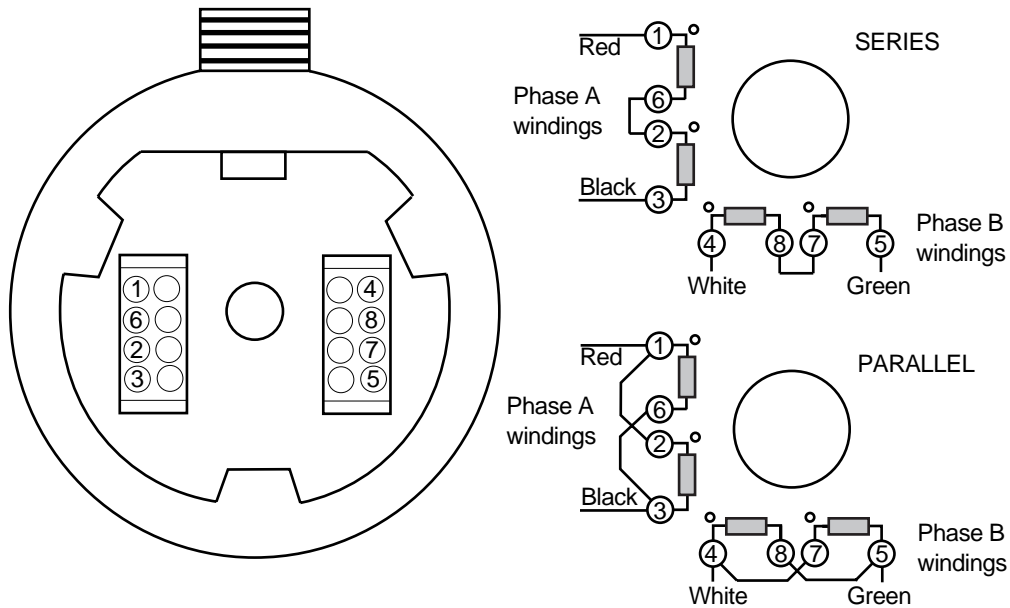

Figure 3-4. QM106-178/S106-178 Series and Parallel Connections

QM106-205/S106-205 Series and Parallel Connections

This motor is pre-wired in series. If you remove the motor's back panel, access is provided to re-wire the motor in parallel.

The motor wiring colour code is:

<u>Motor Terminal</u>	<u>Wire Colour</u>	<u>Drive Terminal</u>
1	Red	A+
3	Black	A-
8	Green	B+
7	White	B-
Body	Bare (Screen)	Gnd

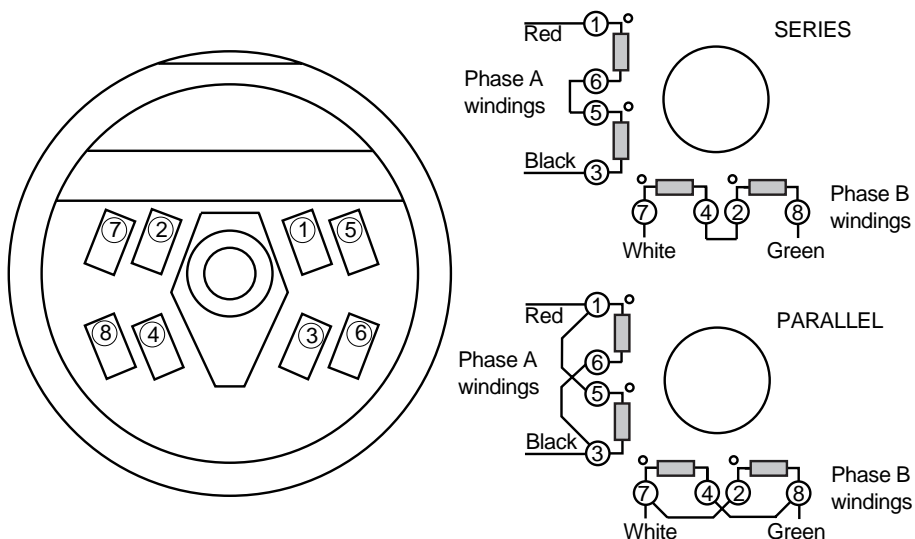

Figure 3-5. QM106-205/S106-205 Series and Parallel Connections

QM106-250/S106-250 Series and Parallel Connections

This motor is pre-wired in series. If you remove the motor's back panel, access is provided to re-wire the motor in parallel.

The motor wiring colour code is:

<u>Motor Terminal</u>	<u>Wire Colour</u>	<u>Drive Terminal</u>
1	Red	A+
3	Black	A-
5	Green	B+
4	White	B-
Body	Bare (Screen)	Gnd

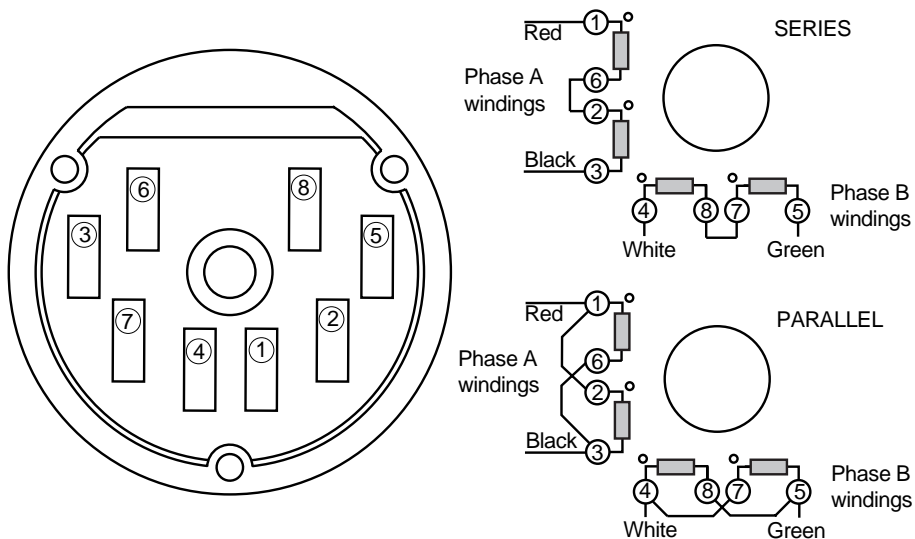

Figure 3-6. QM106-250/S106-250 Series and Parallel Connections

N.C. - no connection.

MAKE	TYPE	A+	A-	B-	B+	NOTES
Sigma	6-lead	Black	Orange	Red	Yellow	White/Blk/Org, White/Red/Yel N.C.
	8-lead	Black	Orange	Red	Yellow	Link Wh/Blk & Wh/Org Link Wh/Red & Wh/Yel
	T.box	1	3	2	4	Link 5 & 6,link 7 & 8
Astrosyn, Rapidsyn, Slo-syn	6-lead	Red	Red/Wh	Grn	Grn/Wh	White & Black N.C.
	T.box (x6)	1	3	4	5	2 & 6 N.C.
Slo-syn	8-lead	Red	Red/Wh	Grn	Grn/Wh	Link Black & White, link Org & Blk/Wh
	T.box (x8)	1	3	5	4	Link 2 & 6, link 7 & 8
Stebon, Digiplan SM	8-lead	Red	Yel	Pink	Blk	Link Blue & violet, link White & Grey
	T.box	1	2	3	4	Link 5 & 6, link 7 & 8
M.A.E.	6-lead	Grn/Wh	Grn	Red	Red/Wh	White & Black N.C.
	8-lead	Black	Orange	Red	Yellow	Link Wh/Blk & Wh/Org, Link Wh/Red & Wh/Yel
	T.box	6	5	8	7	Link 1 & 3, link 2 & 4
Zebotronics	T.box	1	4	5	8	Link 2 & 3, link 6 & 7
Oriental	6-lead	Black	Green	Red	Blue	Yellow & White N.C.
Sonceboz	8-lead	Green	Grn/Wh	Red	Red/Wh	Link Org & Blk/Wh, link Black & White
Japan Servo	6-lead	Red	Blue	Green	Yellow	2 x White N.C.
Escap	8-lead	Brown	Org/Wh	Red	Yel/Wh	Link Brn/Wh & Org, Link Red/Wh & Yellow.
Bodine	8-lead	Brown	Orange	Yellow	Red	Link Wh/Brn & Wh/Org, link Wh/Yel & Wh/Red.
	T.box	1	3	4	2	Link 5 & 7,link 6 & 8
Digiplan/Compumotor OEM Series†	4-lead	-	-	-	-	Internally wired in parallel
	8-lead	Red	Black	Green	White	Link blue & yellow Link orange & brown
Digiplan/Compumotor QM Motor	8-lead	Red	Black	White	Green	Link Yel & Blue Link Org & Brown
Digiplan/Compumotor S Motor	8-lead	Red	Black	White	Green	Link Yel & Blue Link Org & Brown

† Size 23 only. Size 34 can only be operated in Parallel.

Table 3-1. Motor Connection Data - Windings in Series

14 PDS SERIES DRIVE USER GUIDE

For 6-lead motors, connections shown are for one half-winding.
N.C. - no connection.

MAKE	TYPE	A+	A-	B-	B+	NOTES
Sigma	6-lead	Black	Wh/Blk/ Orange	Red	Wh/Red/ Yellow	Or & Yellow N.C.
	8-lead	Black & Wh/Or	Or & Wh/Blk	Red/ Wh/Yel	Yel & Wh/Red	
	T.box	1 & 5	3 & 6	2 & 7	4 & 8	
Astrosyn, Rapidsyn, Slo-syn	6-lead	Red	Black	Green	White	Red/Wh & Grn/Wh N.C.
	T.box(x6)	1	6	4	2	3 & 5 N.C.
Slo-syn	8-lead	Red & White	Blk & Red/Wh	Grn & Blk/Wh	Org & Grn/Wh	
	T.box(x8)	1 & 2	3 & 6	4 & 7	5 & 8	
Stebon, Digiplan SM	8-lead	Rd & Blue	Yel & Violet	Wh & Pink	Black & Grey	
	T.box	1 & 6	2 & 5	3 & 8	4 & 7	
M.A.E.	6-lead	Grn/Wh	White	Red	Black	Grn & Red N.C
	8-lead	Black & Wh/Or	Or & Wh/Blk	Red & Wh/Yel	Yel & Wh/Red	
	T.box	3 & 6	1 & 5	4 & 8	2 & 7	
Zebotronics	T.box	1 & 2	3 & 4	5 & 6	7 & 8	
Oriental	6-lead	Black	Yellow	Red	White	Grn & Blue N.C.
Sonceboz	8-lead	Grn & Blk/Wh	Or & Grn/Wh	Red & White	Blk & Red/Wh	
Japan Servo	6-lead	Red	White*	Green	White*	
Escap	8-lead	Brn & Orange	Brn/Wh & Org/Wh	Red & Yellow	Red/Wh & Yel/Wh	
Bodine	8-lead	Brn & Wh/Or	Wh/Brn & Orange	Yel & Wh/Red	Wh/Yel & Red	
	T.box	1 & 7	3 & 5	4 & 6	2 & 8	
Digiplan/Compumotor OEM Series†	4-lead	Red	Black	Green	White	
	8-lead					
Digiplan/Compumotor QM Motor	8-lead	Red & Blue	Blk & Yellow	Wh & Brn	Green & Org.	
Digiplan/Compumotor S Motor	8-lead	Red & Blue	Black & Yellow	White & Brown	Green & Orange	

* Use correct White for each phase.

† Size 34 only. Size 23 can only be operated in Series.

Table 3-2. Motor Connection Data - Windings in Parallel

Drive Current Setting

SWITCH SETTINGS			PDS13-2 PEAK CURRENT	PDS15-2 PEAK CURRENT
6	7	8		
ON	ON	ON	3.0A	5.0A
OFF	ON	ON	2.7A	4.6A
ON	OFF	ON	2.4A	4.3A
OFF	OFF	ON	2.1A	3.9A
ON	ON	OFF	1.8A	3.6A
OFF	ON	OFF	1.5A	3.2A
ON	OFF	OFF	1.2A	2.9A
OFF	OFF	OFF	0.9A	2.5A

Table 3-3. Peak Current Settings

Compumotor S and QM Motor Drive Settings

When using Compumotor 'S' and 'QM' motors you will need to set the PDS drive current settings as shown in Table3-4.

The 'S' motor and 'QM' motor are electrically identical e.g. an S57-51 is the same as QM57-51. In the following table, under motor type, a suffix 'S' refers to series connected and 'P' refers to parallel connected.

Motor Type	PDS13-2			PDS15-2			Peak Motor Current Rating (Amps)	Rotor Inertia Kg-cm ² (oz-in ²)
	SW6	SW7	SW8	SW6	SW7	SW8		
S/QM-57-51S	ON	OFF	OFF	*	*	*	1.2	0.088 (0.48)
S/QM-57-51P	ON	OFF	ON	OFF	OFF	OFF	2.3	
S/QM-57-83S	OFF	ON	OFF	*	*	*	1.5	0.234 (1.28)
S/QM-57-83P	ON	ON	ON	OFF	ON	OFF	3.1	
S/QM-57-102S	ON	ON	OFF	*	*	*	1.7	0.32 (1.75)
S/QM-57-102P	ON	ON	ON	ON	ON	OFF	3.5	
S/QM-83-62S	OFF	OFF	ON	*	*	*	2.2	0.64 (3.50)
S/QM-83-62P	ON	ON	ON	OFF	ON	ON	4.4	
S/QM-83-93S	ON	ON	ON	ON	OFF	OFF	2.9	1.23 (6.70)
S/QM-83-93P	X	X	X	ON	ON	ON	5.6	
S/QM-83-135S	ON	ON	ON	ON	ON	OFF	3.5	1.87 (10.24)
S/QM-83-135P	X	X	X	ON	ON	ON	6.9	

Table 3-4. PDS Current Drive Settings for Compumotor 'S' and 'QM' Motors

Motor Type	PDS13-2			PDS15-2			Peak Motor Current Rating (Amps)	Rotor Inertia Kg-cm ² (oz-in ²)
	SW6	SW7	SW8	SW6	SW7	SW8		
S/QM-106-178S	X	X	X	ON†	ON†	ON†	6.0	8.05 (44.0)
S/QM-106-178P	X	X	X	ON†	ON†	ON†	12.0	
S/QM-106-205S	X	X	X	ON†	ON†	OFF†	3.6	9.51 (52.00)
S/QM-106-205P	X	X	X	ON†	ON†	ON†	7.2	
S/QM-106-250S	X	X	X	ON†	ON†	ON†	6.2	12.14 (63.00)
S/QM-106-250P	X	X	X	ON†	ON†	ON†	12.4	

Table 3-5. PDS Current Drive Settings for Compumotor ‘S’ and ‘QM’ Motors (Continued)

- Note * Minimum drive current too high for motor.
 X Unsuitable motor/drive combination.
 † 106 (42) size motors must use PDS15-D-2 option (regenerative power dump).
 PDS13-2 is 3 amps Peak Max. and PDS15-2 is 5 amps Peak Max.

Compumotor OEM Motor Drive Settings

The 34 frame size motors (OEM-83-62/93/135) have identical drive current settings to the ‘QM’ motors listed in Table 3-4. Size 34 (83) motors are internally wired in Parallel.

In Table 3-6, under ‘Motor Type’, a suffix ‘S’ refers to series connected. The parallel connection can not be used for size 23 (57) motors.

Motor Type	PDS13-2			PDS15-2			Peak Motor Current Rating (Amps)	Rotor Inertia Kg-cm ² (oz-in ²)
	SW6	SW7	SW8	SW6	SW7	SW8		
OEM-57-40S	OFF	ON	ON	OFF	OFF	OFF	2.7	0.07 (0.380)
OEM-57-51S	ON	ON	ON	OFF	ON	OFF	3.3	0.12 (0.650)
OEM-57-83S	ON	ON	ON	ON	ON	OFF	3.8	0.25 (1.360)

Table 3-6. PDS Current Drive Settings for Compumotor ‘OEM’ Motors

Digiplan SM and STEBON Motor Drive Settings

Table 3-7 lists the PDS Drive current settings you need to make when using Digiplan ‘SM’ and STEBON motors.

In Table 3-7, under ‘Motor Type’, a suffix ‘S’ refers to series connected and ‘P’ refers to parallel connected.

Motor Type	PDS13-2			PDS15-2			Peak Motor Current Rating (Amps)	Rotor Inertia Kg-cm ² (oz-in ²)
	SW6	SW7	SW8	SW6	SW7	SW8		
SM-57-51S	OFF	OFF	OFF	*	*	*	1.1	0.11 (0.60)
SM-57-51P	OFF	OFF	ON	*	*	*	2.1	
SM-57-83S	OFF	OFF	ON	*	*	*	2.3	0.23 (1.26)
SM-57-83P	ON	ON	ON	OFF	ON	ON	4.7	
SM-57-102S	OFF	OFF	ON	*	*	*	2.3	0.30 (1.64)
SM-57-102P	ON	ON	ON	OFF	ON	ON	4.6	
SM-83-62S	ON	ON	ON	OFF	ON	OFF	3.2	0.60 (3.30)
SM-83-62P	X	X	X	ON	ON	ON	6.4	
SM-83-93S	ON	ON	ON	OFF	OFF	ON	4.0	1.25 (6.83)
SM-83-93P	X	X	X	ON	ON	ON	7.9	
SM-83-135S	ON	ON	ON	ON	ON	OFF	3.8	2.00 (10.93)
SM-83-135P	X	X	X	ON	ON	ON	7.6	
SM-106-140S	X	X	X	OFF†	ON†	ON†	5.0	3.65 (19.96)
SM-106-140P	X	X	X	ON†	ON†	ON†	9.9	

Table 3-7. PDS Current Drive Settings for Digiplan 'SM' and STEBON Motors

Note * Minimum drive current too high for motor.
 X Unsuitable motor/drive combination.
 † 106 (42) size motors must use PDS15-D-2 option (regenerative power dump).
 PDS13-2 is 3 amps Peak Max. and PDS15-2 is 5 amps Peak Max.

Signal Connections

Step + Pin 1 & Step- Pin 14

A pulse on these inputs causes the motor to advance on the leading edge of the pulse (see Figure 3-7). The pulse should be at least 1 μ s long. Consult your indexer user guide for instructions on how to change the output pulse width.

The Step inputs are configured as TTL opto isolated inputs.

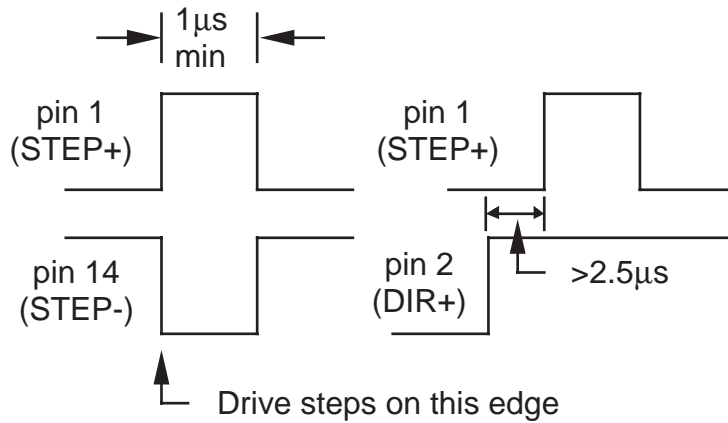

Figure 3-7. STEP Timing Diagram

Direction+ Pin 2 & Direction- Pin 15

These inputs (pins 2 and 15) control the direction of the motor shaft rotation. Changing the level of these inputs changes the direction in which the shaft moves. The logic level at this input needs to be present for at least 2.5µs before the leading edge of the step pulse [transition to STEP+ (high) STEP- (low)].

The Direction inputs are configured as TTL opto isolated inputs.

Slow Rate Adjust (Pin 6)

An external variable resistor (100K Ohm, 10 turn recommended) or a fixed resistor may be connected between this terminal and "Adjust Common" (pin 19) to control the slow speed of the internal clock source. When using external speed controls, turn switch 3 off in order to isolate the internal potentiometers.

Fast Rate Adjust (Pin 7)

An external variable resistor (10K Ohm, 10 turn recommended) or fixed resistor may be connected between this terminal and "Adjust Common" (pin 19) to control the fast speed of the internal clock source. When using external speed controls, turn switch 3 off in order to isolate the internal potentiometers.

Fault (Pin 9 & 21)

This output is a transistor signal which turns on in the event of a fault. See Figure 3-8 for possible external wiring connections.

When a fault occurs, the drive will de-energise. Once the fault has been cleared the drive may be re-energised by either cycling the Shutdown signal or by cycling the power to the drive.

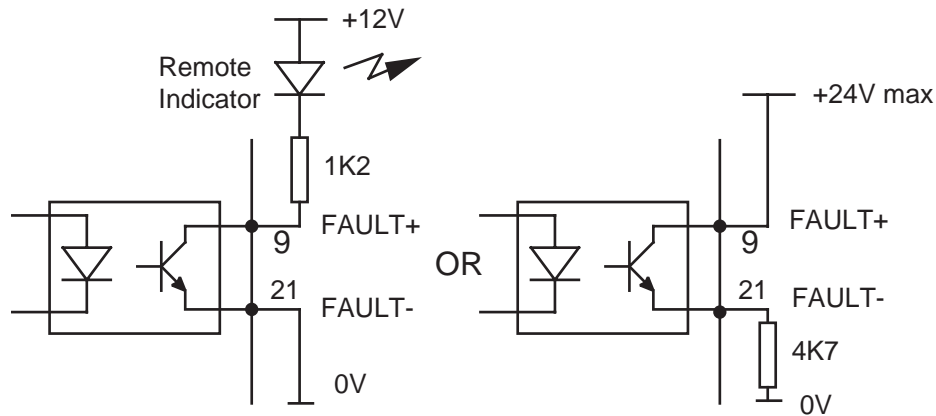

Figure 3-8. Fault Output Examples

Slow Run (Pin 12)

Connect this input to GND directly to run the internal clock source at the slow rate.

Fast Run (Pin 13)

Connect this input to GND directly to run the internal clock source at the fast rate.

Shutdown+ Pin 16 & Shutdown- Pin 17

These differential inputs (pins 16 and 17) are used to energise and de-energise (shutdown) the motor. When the shutdown+ input is taken high and shutdown- is low, the drive is shut down and, if it is safe to do so, the motor shaft may be rotated **slowly** by hand.

NOTE: Back-driving the motor at excessive speed may damage the drive.

Cycling the shutdown input resets a fault condition, provided the cause of the fault has been removed.

Adjust Common (Pin 19)

Common return connection for external speed controls (nominal +12V).

Internal Clock Out (Pin 20)

This open collector output (NPN transistor) goes low every time the drive sees a step pulse from the internal clock source. It must be pulled up using an external resistor. Pulse width is $1\mu\text{s}$, consequently this clock is not compatible with the Aux Clock In on pin 23, since the pulse width is too narrow to pass through the input filter. It cannot therefore be connected to the Aux Clock In on another drive in order to slave two drives from one oscillator. Should you wish to do this, you will need to feed the Internal Clock Out via a differential driver into the Step+/Step- inputs on the second drive.

Aux Clock In (Pin 23)

A low going pulse on this input causes the motor to advance on the leading edge of the pulse (see Figure 3-9). The pulse should be at least $8\mu\text{s}$ long. Consult your indexer user guide for instructions on how to change the output pulse width.

Aux Direction In (Pin 24)

This input controls the direction of the motor shaft rotation. Changing the level of this input changes the direction in which the shaft moves. The logic level at this input needs to be present for at least 8µs before the leading edge of the step pulse.

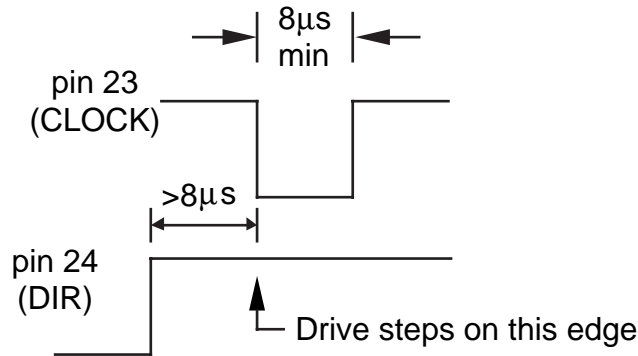

Figure 3-9. Aux CLOCK Timing Diagram

GND (Pin25)

Control signal return.

Compatibility of Type 2 Drives

Type 2 drives have differential Step and Direction inputs which are fully opto-isolated. Unlike the PDS13, PDS15 and PDS15-D Series, these inputs cannot be driven from a single-ended source without an external power supply. To use a single-ended source, use the inputs Aux Clock In (pin 23) and Aux Direction In (pin 24). These inputs are pulled up internally to +12V via a 4K7 resistor and are therefore suitable for driving from an NPN open-collector source.

If you are using the preferred differential drive for the Step and Direction inputs (i.e. true differential driver connected between Step+ and Step-) the type 2 drive can be used with the same connections as the previous version.

Note that to achieve adequate noise immunity with single-ended inputs, signal filtering is used. This limits the minimum pulse width to 8µs and the frequency to 50KHz. Therefore the maximum shaft speed at full resolution (4000 steps/rev) is 750 rpm. The full 3000 rpm range can only be achieved at resolutions of 1000 steps/rev or lower.

Internal Speed Control

The drive contains a two speed oscillator circuit to allow “jogging” of the motor. This clock source produces a linear ramp up to the FAST speed setting. The SLOW speed setting is not ramped. Three 20 turn potentiometers are provided on the front panel to adjust the settings of the oscillator. The SLOW and FAST presets adjust the frequency of the corresponding range and hence the motor velocity. Note that motor resolution does not effect the velocity setting. Clockwise rotation of a potentiometer produces an increase in motor velocity. The FAST and SLOW potentiometers can optionally be replaced by

externally wired, remote potentiometers - see Figure 3-10. These external controls can be used to give a machine operator remote control of the motor.

Clockwise rotation of the ACCEL potentiometer increases the rate of motor ramp up to a maximum possible figure of 500 rps². The ACCEL potentiometer can not be replaced by an external variable resistor.

Optional Advance Rate Pot and Switch Connections

Figure 3-10 shows typical external connections required when using the internal clock source. External variable resistance values of 100K for Slow and 10K for Fast are recommended.

When using external speed controls, turn switch 3 off in order to isolate the internal potentiometers.

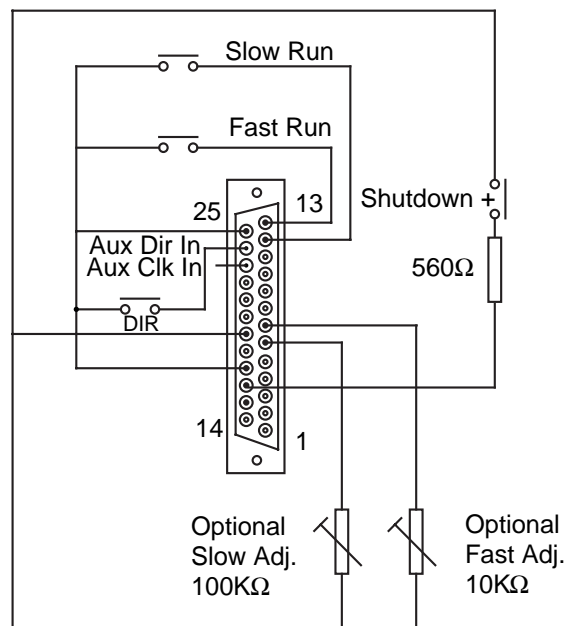

Note: Screened cable should be used (maximum length 2 metres)

Figure 3-10. Signal Connections

Input Circuits

The Step, Direction and Shutdown inputs are configured as differential TTL compatible opto-isolated inputs with reverse polarity protection. Figure 3-11 shows details of the input circuits used.

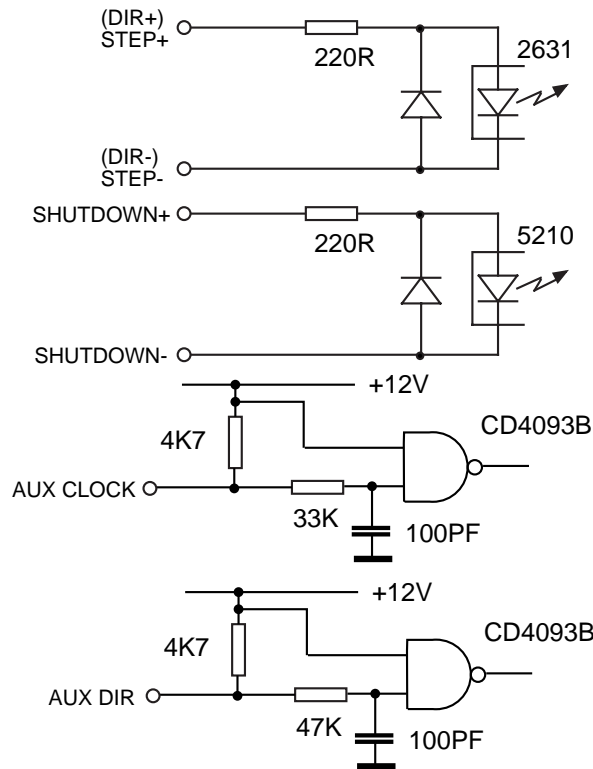

Figure 3-11. Drive Input Circuits

Using the PDS with Compumotor 6000 Series Controllers

The PDS directly connects to 6000 series stepper controllers using the Indexer-Drive cable supplied with the 6000 product. When setting up the controller, the following commands should be used to match drive and indexer:

- PULSE:** Must be set to 1µs or greater
- DRES:** Set indexer to the same resolution as the drive(s). Drive resolution is configured by switches 4 and 5. Valid settings are 400, 1000, 2000 or 4000 steps per rev.
- DRFLVL:** Set to active low (default for 6000 series)

Example of 2 axes of PDS connected to 6200 controller:

Command	Description
PULSE1,1	Sets the 6200 to 1µs pulse width
DRES4000,4000	Set indexer to same resolution as drive (4000 steps/rev).

DRFLVL0	Fault signals are active low
INFEN1	Enable input functions

Note that if a drive fault occurs and is cleared, a 6000 controller can automatically reset the drive latch by toggling the shutdown input signal as follows:

<u>Command</u>	<u>Description</u>
DRIVE00	Shutdown both axes (motors de-energised)
DRIVE11	Enable both drives and clear fault latches.

Mechanical/ Environmental

The drive and its switch mode power supply are contained in a single case measuring 250mm (9.84 inches) High, by 50mm (1.97 inches) Wide, by 190mm (7.5 inches) Deep. Note: The depth does not take connector dimensions into account. These need an additional 60mm.

You should install the drive system in an enclosure to protect it against atmospheric contaminants such as oil, moisture, dirt etc. This also prevents operator access and assists the EMC performance by limiting emissions and adding to the rf immunity.

Ideally, you should install the system in a cabinet. In the USA, the National Electrical Manufacturers Association (NEMA) has established standards that define the degree of protection that electrical enclosures provide. The enclosure should conform to NEMA Type 12 standards if the intended environment is industrial and contains airborne contaminants. Proper layout of components is required to ensure sufficient cooling of equipment within the enclosure.

Environmental

Digiplan recommends you operate and store your PDS Drive system under the following conditions:

- Operating Temperature: 0° to 40°C (32° to 104°F)
- Relative Humidity: 0% to 95% (non-condensing)
- Storage Temperature: -40° to 85°C (-40° to 185°F)

The recommended orientation of the drive enclosure is back panel, vertical mounting.

In exceptional circumstances, such as running the motor continuously at maximum current, forced-air cooling may be needed to maintain the local ambient temperature within specification.

The mains input to the drive should be Installation Category II maximum.

The PDS series of drives can be used in a Pollution Degree 2 environment i.e., one in which only non-conductive pollution occurs.

Installation Considerations

The drive is designed to be installed vertically as shown in Figure 3-12. Air vents on the top and bottom panels allow convection cooling.

At least 50mm minimum clearance around the air vents is recommended for unobstructed ventilation and reliable operation.

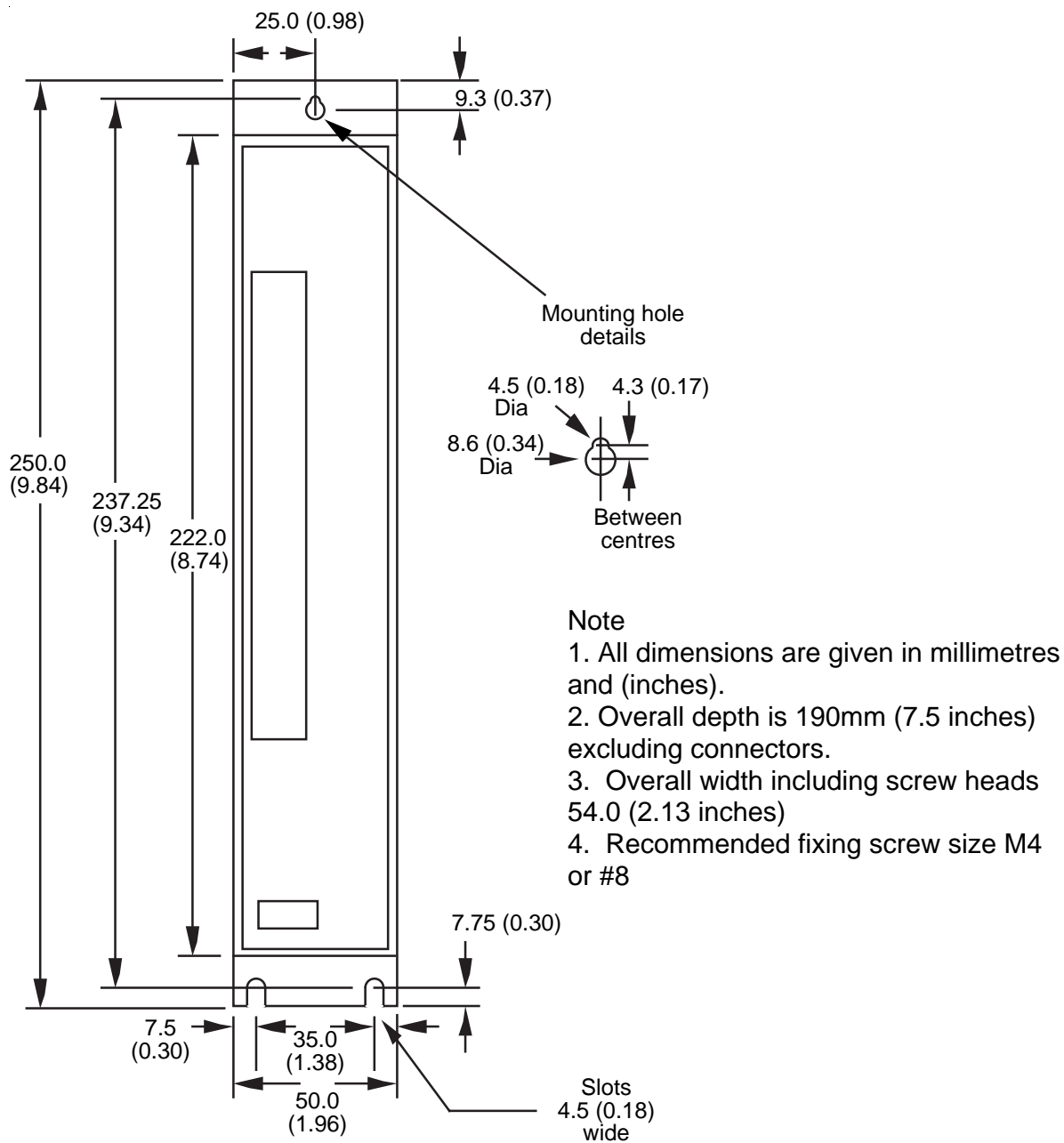

Figure 3-12 Drive Mounting Hole Locations

EMC Installation

It should be stressed that although these recommendations are based on the expertise acquired during the development of fully compliant products, and on tests carried out on each of the product types, it is impossible for Digiplan to guarantee the compliance of any particular installation. This will be strongly influenced by the physical and electrical details of the installation and the performance of other system components. Nevertheless it is important to follow *all* the installation instructions if an adequate level of compliance is to be realisable.

External enclosures

The measures described in these recommendations are primarily for the purpose of controlling mains conducted emissions. To control radiated emissions, all PDS drives and rack systems must be installed in a steel equipment cabinet which will give adequate screening against radiated emissions. This external enclosure is also required for safety reasons. With the exception of drive front panels in rack-based units, there must be *no user access* while the equipment is operating. This is usually achieved by fitting an isolator switch to the door assembly. Drives and filters must be mounted to a conductive panel. If this has a paint finish, it will be necessary to remove the paint in certain areas where required.

To achieve adequate screening of radiated emissions, all panels of the enclosure must be bonded to a central earth point. The enclosure may also contain other equipment such as motion controllers, and the EMC requirements of these must be considered during installation. Always ensure that drives and rack systems are mounted in such a way that there is adequate ventilation.

Before mounting the drive, remove the paint from the rear face of the lower mounting lug as shown in Figure 3-13 (if not already removed), and if necessary from the corresponding area on the rear panel of the enclosure. This is to guarantee a good high-frequency connection between the drive case and the cabinet. Use petroleum jelly on the exposed metal to minimise the risk of future corrosion.

AC Supply Filtering

These recommendations are based on the use of proprietary mains filter units which are readily available. However, the full EMC test includes a simulated lightning strike which will damage the filter unless adequate surge suppression devices are fitted. These are not normally incorporated into commercial filters since the lightning strike test can be destructive. This test is normally carried out on the overall system and not on individual components, therefore the surge protection should be provided at the system boundary.

Try to arrange the layout of drive and filter so that the AC input cable is kept away from the filter output leads. It is preferable for the current path to be as linear as possible without doubling back on itself - this can negate the effect of the filter. Mount the filter within 50mm of the drive, and run the input cable and any earth cables close to the panel.

PDS drives incorporate a switch-mode power supply operating directly from the AC input. The substantial filtering effect of a mains isolation transformer is therefore not available, and additional external filtering is required. The solution offered uses a single filter in order to control both differential and common-mode emissions. The manufacturer's part number for a suitable filter is:

CORCOM 6EQ1

Mount the filter within 50mm of the drive as shown in Figure 3-13. Again ensure that there is no paint on the rear panel behind the filter mounting lugs - it is vital that there is good large-area contact between the filter and the panel.

Mains Cable

Connect the incoming AC supply cable to the push-on terminals on the 'LINE' end of the filter, with the earth lead connected to a local earth stud or bus bar. Connect the earth terminal on the case of the filter to the earth stud. Route the supply cable so that it runs close to the rear panel within the cabinet.

3-core 1mm² screened cable (with a braided screen) must be used between the output of the filter and the input to the drive with a voltage rating of at least 1350V AC. Connect the earth wire to the earth stud, and arrange all the earth leads so they run close to the panel. Expose a short length of the screen and anchor the cable close to the filter with a P-clip. Remove any paint from the panel behind the P-clip. Fit a ferrite absorber over the cable and wire up the power connector - no connection is made to the screen at the drive end. Locate the absorber as close as possible to the connector using heat-shrink sleeving.

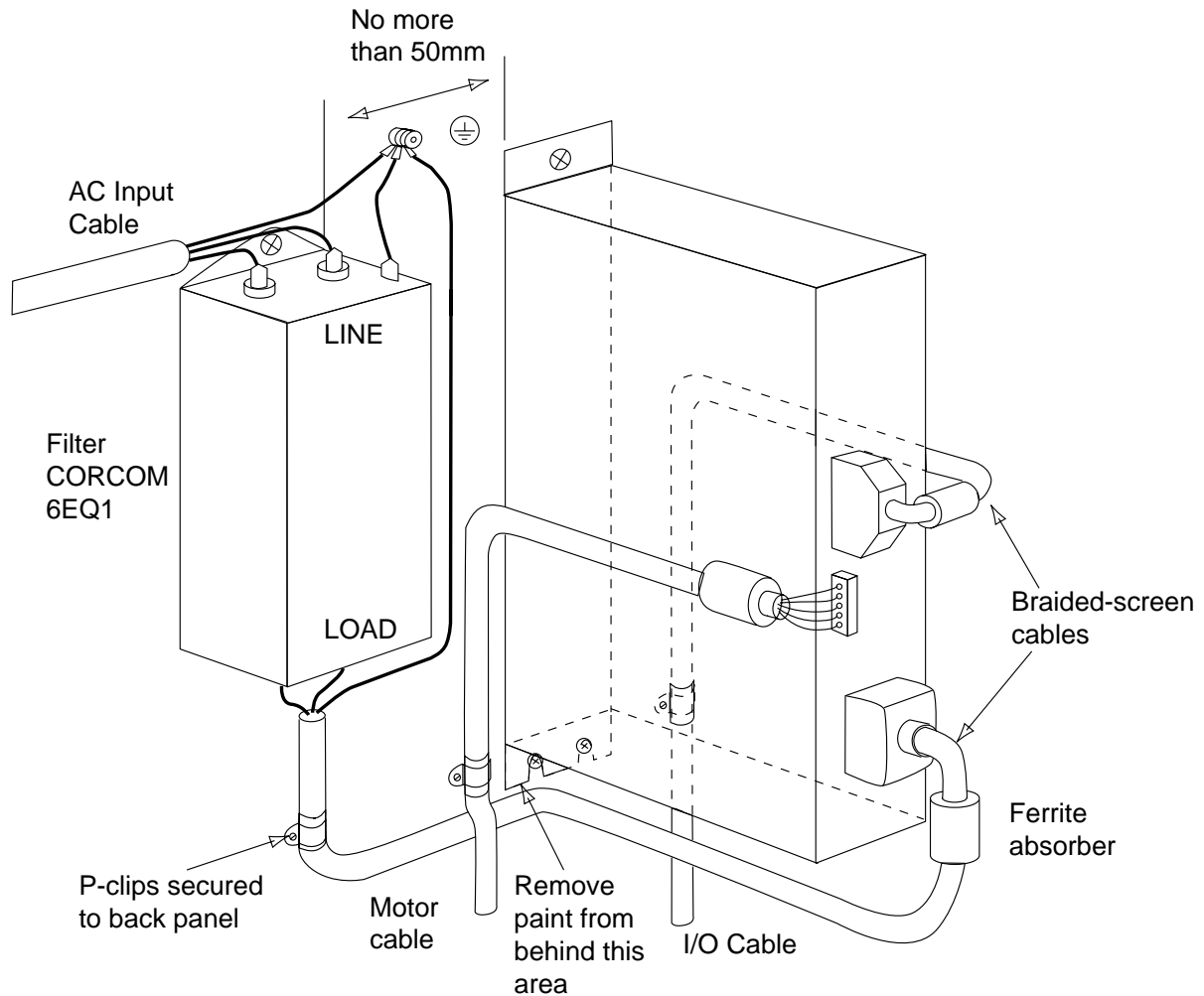

Figure 3-13. EMC Installation

Motor cables

All motor connections must be made using a high quality braided-screen cable. Cables using a metallised plastic bandage for an earth screen are unsuitable and in fact provide very little screening. There is a problem in terminating to the screen in a mechanically stable manner and the screen itself is comparatively fragile - bending it round a tight radius can seriously affect the screening performance.

There must be no break in the 360° high optical coverage that the screen provides around the cable conductors. If a connector must be used it should retain the 360° coverage, possibly by the use of an additional metallic casing where it passes through the bulkhead of the enclosure. The cable screen must *not* be bonded to the cabinet at the point of entry. Its function is to return high-frequency chopping current back to the drive. This may require mounting the connector on a sub-panel insulated from the main cabinet, or using a connector having an internal screen which is insulated from the connector housing.

Within the cabinet itself, all the motor cables should lie in the same trunking as far as possible. They must be kept separate from any low-level control signal cables. This applies particularly where the control cables are unscreened and run close to the drive or rack system.

Stepper motors

It is preferable to use motors with screw terminations whenever possible. If flying-lead motors are used, it is important that the unscreened leads are converted into a braided-screen cable within 100mm of the motor body. A separate terminal box may be used for this purpose but the braided cable screen must be properly strapped to the motor body. Motors fitted with terminal boxes also allow local selection of series or parallel connection, reducing the cost of the cable running back to the drive.

Motor connections

Use 5-core 1mm² screened cable for the motor connections, for example Lapp 34805. At the drive end, fit a ferrite absorber over the cable before wiring to the motor connector. No connection is made to the cable screen at this end. Locate the absorber as close as possible to the connector using heat-shrink sleeving.

Run the motor cable back to the rear panel and down between the drive and the filters. Expose a short length of braiding and anchor to the rear panel with a P-clip. Note that the motor cable should preferably be kept at least 300mm away from I/O cables carrying control signals.

Termination at the motor must be made using a 360° bond to the motor body, and this may be achieved by using a suitable clamp. Many stepper motors are designed to accommodate an appropriate conductive terminal gland which can be used for this purpose.

Control signal wiring

High-quality braided screen cable should be used for control connections. In the case of the PDS drive which has differential step-direction inputs, it is preferable to use cable with twisted pairs to minimise magnetic coupling. No connection is made to the cable screen at the D-connector on the drive. Fit a ferrite absorber close to the D-connector and run the cable back to the rear panel as shown in Figure 3-13. Expose a short length of the braided screen and anchor to the rear panel with a P-clip.

Ferrite absorber specifications

The absorbers described in these installation instructions are made from a low-grade ferrite material which has high losses at radio frequencies. They therefore act like a high impedance in this waveband.

The recommended components are produced by Parker Chomerics and are suitable for use with cable having an outside diameter up to 10mm. The specification is as follows:

Chomerics part number	H8FE-1115-NC
Outside diameter	17.5mm
Inside diameter	10.7mm
Length	28.5mm
Impedance at 25MHz	80
Impedance at 100MHz	120
Curie temperature	130°C (the device should not be operated near this temperature)

Handling and installing the ferrite absorbers

Take care when handling the absorbers - they can shatter if dropped on a hard surface. For this reason the suggested method of installation is to use a short length of 19mm diameter heat-shrink sleeving. This gives a degree of physical protection while the cable is being installed. The sleeving should have a shrink ratio of at least 2.5:1. Cable ties may be used as an alternative, however they give no physical protection to the absorber.

Section 4. Setting Up

Drive Switch Settings

These settings are intended to be changed only by qualified service personnel. Operator access to the drive should not be permitted. Take care, unexpected motion may occur at any time, especially during the commissioning of motion control equipment.

SWITCH NUMBER	FUNCTION	COMMENTS
1	Selftest	Default OFF
2	Standby current reduction	Default ON
3	INT/EXT speed control	Default OFF
4, 5	Step resolution	Default all OFF
6, 7, 8	Peak current setting	Default all ON

Table 4-1. Switch Settings

Selftest Switch 1

The selftest switch is used to check the operation of the drive. Set to the ON position to cause the motor to rotate at the slow speed potentiometer setting. The default setting of selftest is OFF, that is, not selected.

Standby Switch 2

Switch 2 determines the level of standby current. With switch 2 ON, the current will reduce by 50% at standby. With switch 2 OFF, current will be reduced to 80% of the programmed value at standby.

Switch 3

Turn the switch ON for internal speed control or OFF for external speed control. **This switch must be ON to enable the self test facility, if external speed potentiometers are not connected.**

Step Resolution Switch 4, 5

DIP Switches 4 and 5 determine the step resolution of the drive, as defined in Table 4-2. Note: cycle the power for switch settings to take effect.

SWITCH SETTINGS		RESOLUTION IN STEPS/REV
4	5	
ON	ON	400
ON	OFF	1000
OFF	ON	2000
OFF	OFF	4000

Table 4-2. Step Resolution Settings

Peak Current Setting Switch 6, 7, 8

DIP Switches 6, 7 and 8 determine the peak current setting of the drive, as defined in Table 4-3.

SWITCH SETTINGS			PDS13-2 PEAK CURRENT	PDS15-2 PEAK CURRENT
6	7	8		
ON	ON	ON	3.0A	5.0A
OFF	ON	ON	2.7A	4.6A
ON	OFF	ON	2.4A	4.3A
OFF	OFF	ON	2.1A	3.9A
ON	ON	OFF	1.8A	3.6A
OFF	ON	OFF	1.5A	3.2A
ON	OFF	OFF	1.2A	2.9A
OFF	OFF	OFF	0.9A	2.5A

Table 4-3. Peak Current Settings

Acceleration/Deceleration Rate Adjustment

The acceleration and deceleration rates of the drive are controlled by the front panel acceleration control, which provides a range of 20 to 500 rev/sec/sec.

Preliminary Testing for Service Personnel Only

Initially do not make any connections to the 25-way D-type connector. With power OFF, ensure that switch 3 is in the ON position and that the motor is connected correctly. Set the SLOW potentiometer to its mid-way position (the potentiometers are all 20 turn). Ensure the motor is securely clamped in position. Apply power and if it is safe to do so, check the motor for holding torque. The red FAULT LED should be OUT and the green POWER LED should be illuminated (ON). If all is well, close switch 1 and the motor will start turning. The velocity can be varied by rotating the SLOW potentiometer (clockwise increases velocity). The success of this preliminary test confirms correct drive-motor wiring. Power down and turn OFF switch 1.

If you wish, you can now plug in your Compumotor Indexer cable and test the drive using the indexer. Alternatively, by making the wiring connections shown in Figure 3-10 you can operate the drive via the internal clock source.

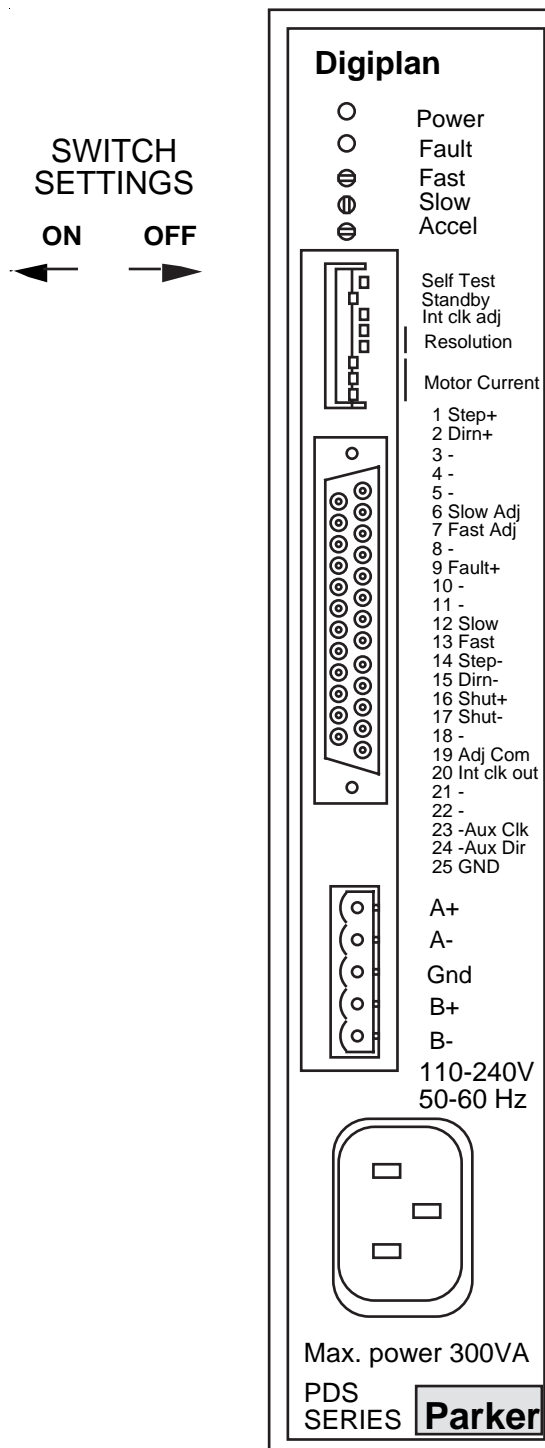

Figure 4-1. Front Panel Layout

Section 5. Maintenance & Troubleshooting

Maintenance

Your attention is drawn to the safety warning given at the beginning of this User Guide. During troubleshooting be aware that unexpected motion may occur at any time.

Routine maintenance is not necessary, but occasional checking of the following points is recommended.

Motor Maintenance

Periodically check the motor to ensure that no bolts or couplings have become loose during operation, and check the motor cable or leads periodically for signs of wear. Do not make very tight bends or pull on the cable during normal operation. Check all cable connectors.

Drive Maintenance

Check that the drive is clear of loose material and has a free flow of air through the ventilation slots. Enclosures must be connected to earth ground to provide a low-impedance path for ground-fault or noise-induced currents. Check the security of the ground connections.

Troubleshooting

Fault LED

The red LED indicates one of the following fault conditions:

1. Motor wiring short-circuit either across phases or between phases.
2. Motor wiring short-circuit phase to GND (earth).
3. Motor supply overvoltage or undervoltage.
4. Internal supply failure.
5. Drive internal overtemperature.

The fault LED will also light up if the motor is decelerating a high inertia load too quickly. The drive will shut down under this condition. If this occurs, you can either reduce the deceleration rate/load inertia, or use a PDS15-D-2 (power dump option). See INSTALLATION section for more information on the regenerative power dump option.

Note that the fault LED comes on momentarily when power is removed from the drive. This is caused by the supply rails dropping below a safe operating level, and is an indication that the fault circuitry is functioning correctly. You should always ensure that the fault LED is extinguished before re-applying the power.

Motor Fails to Move

If it is safe to do so, test the motor to see if it has holding torque. If there is no holding torque, here are some probable causes:

- There is no power.
- Current DIP switch selection is not set properly.
- There are bad connections or bad cables in the motor circuit. Disconnect the power to the drive and remove the motor connector. Using a meter, check the continuity in the motor circuit between pins A+ and A- of the motor connector. Repeat for pins B+ and B-.
- Check the resistance of the motor and cables to make sure that shorts do not exist between phases or to earth GND. The resistance across each motor phase should be consistent and there should be no connection between motor phases and between each phase and earth ground.
- Check the motor cables for signs of damage.
- The shutdown input may be active.
- If the power LED is out and the motor will not energise, the drive must be returned for repair.

If the unit has holding torque and the motor shaft still fails to move, here are some possible causes:

- The load is jammed. You should *hear* the drive attempting to move the motor. Remove power from the driver and verify that you can move the load manually away from the point of the jam.
- Clock pulses are not reaching the drive, or the signal levels are inadequate. If possible, check the signal levels with an oscilloscope. Try running the motor using the self-test switch.

Motor Stalls

A motor stall during acceleration may be caused by one or more of the following factors:

- The torque requirements may be excessive.
- The acceleration ramp may be too steep - lower acceleration may be required. Check the torque/speed curves in the published data and make sure you are trying to run the motor within the system capabilities.
- The load inertia and rotor inertia may be grossly mismatched.

If the motor stalls during the constant velocity portion of a move, the shaft and/or coupler may be damaged or binding due to improper coupling or excessive motor load.

A stall may occur if the switch setting for the motor current selection is incorrect. The motor may not be receiving enough current to drive the load.

Motor is Jerky or Weak

Check that there are no mechanical problems at the load causing variable loading conditions. Disconnect the motor from the load and run it without a load connected. Check the switch current settings.

Motor Overheats

If the motor exceeds its maximum motor case temperature rating, failure will eventually result. Check your switch settings to ensure that the current setting is correct for the motor you are using.

Motor Runs the Wrong Way

Turn off the power and interchange the connections between A+ and A- on the motor connector.

Internal Clock Source Will Not Run

If no external speed controls are used, check that switch 3 is ON so that the internal potentiometers are functional.

Self Test Fails to Run Motor

See above.

Returning the System

Contact the Parker Automation Technology Centre or the machinery manufacturer who supplied the product. Equipment for repair should NOT be returned directly to Digiplan without prior authorisation. Repairs will be carried out by Digiplan but will be processed via your supplier.

Digiplan may at their discretion authorise direct shipment to and from Poole or Rohnert Park, but only by prior arrangement with your supplier. Existing UK and USA customers who purchase equipment directly from Digiplan should contact Poole or Rohnert Park for further information (contact numbers are at the front of this User Guide).

Index

- 6
- 6000 Series Controllers, 22
- A
 - Acceleration adjustment, 32
 - Acceleration rate, 32
 - Adjust common return, 19
 - Auxiliary clock input, 19
 - Auxiliary clock timing, 20
 - Auxiliary direction input, 20
- B
 - Bipolar rating, 8
- C
 - Cabinet requirements, 7
 - Cable layout precautions, 25
 - Case dimensions, 23
 - Clock internal, 19
 - Clock output, 19
 - Clock source (int.) will not run, 37
 - Clock source control inputs, 19
 - Clock/step options, 1
 - Compatibility of type 2 drives, 20
 - Compumotor 6000 Series, 22
 - Conducted emissions, 25
 - Conductive terminal gland, 28
 - Control signal wiring (EMC), 28
 - Control signals., 5
 - Cooling considerations, 23
 - Current peak setting switch 6, 7 & 8, 32
 - Current settings peak, 32
- D
 - Dimensions of drive, 24
 - Direction input, 18
 - Direction of rotation, 9
 - Drive maintenance, 35
 - Drive setup, 31
 - Dump option, 8
 - Dump option calculations, 8
- E
 - Earthing requirements, 7
 - EMC Installation, 25
 - EMC installation diagram, 27
 - EMI reduction, 7
 - Environment specification, 5
 - European Standard EN 61010-1, 7
- F
 - Fast Rate, 18
 - Fault LED, 35
 - Fault output, 18
 - Ferrite absorber, 28
 - Ferrite absorber handling procedures, 29
 - Ferrite absorber specification, 29
 - Filter mounting requirements, 26
 - Filter types for EMC, 26
 - Filtering of AC supply, 25
 - Flame barrier, 7
 - Frame size 42 (106) motors, 10
 - Fuse for dump circuit, 4
 - Fuses internal, 4
- G
 - Grounding, 7
- H
 - Holding torque faults, 36
 - Humidity, storage, 23
- I
 - Installation requirements, 7
 - Insulation rating of mains wiring, 7
 - Insulation rating of motor, 9
 - Insulation rating of motor cable, 9
 - Interlocks, 7
- L
 - Long motor leads, 8
- M
 - Mains cable EMC installation, 26
 - Mains input installation category, 23
 - Maintenance, 35
 - Motor cable termination, 28
 - Motor cables (EMC), 27
 - Motor connection fault, 36
 - Motor connections, 9
 - Motor connections (EMC), 28
 - Motor current optimum value, 8
 - Motor earth connection, 9
 - Motor fails to move, 35
 - Motor maintenance, 35
 - Motor specification, 5
 - Motor torque considerations, 8
 - Motor type, 1
 - Mounting clearance, 24
 - Mounting recommendations, 23

- Multiple lead motors, 8
 - N
 - NEMA, 23
 - No holding torque faults, 36
 - O
 - OEM Motor drive, 16
 - Overheating, 37
 - P
 - Parallel connections, 14
 - PDS series, 1
 - Phase to earth faults, 36
 - Pollution degree, 23
 - Power dump calculation program, 8
 - Product description, 1
 - Q
 - QM Motor drive settings, 15
 - QM motors, 10
 - QM106-178 Motor wiring, 11
 - QM106-205 Motor wiring, 11
 - QM106-250 Motor wiring, 12
 - R
 - Radiated emissions, 25
 - Rate adjustment, 18
 - Returning the system, 37
 - Reverse motor direction, 37
 - S
 - S Motor drive settings, 15
 - S motors, 10
 - S106-178 Motor wiring, 11
 - S106-205 Motor wiring, 11
 - S106-250 Motor wiring, 12
 - Safety earth connection to the motor, 10
 - Selftest selection, 31
 - Selftest switch 1, 31
 - Series connection, 13
 - Shutdown input, 19
 - Single ended performance limitations, 20
 - Slow Rate, 18
 - Specification, 3
 - Speed control external, 21
 - Speed control internal, 21
 - Speed control options, 2
 - Speed control switch 3, 31
 - Speed selection INT or EXT, 31
 - Stalling, 36
 - Standby selection, 31
 - Standby switch 2, 31
 - Stebon motors, 16
 - Step input, 17
 - Step resolution switch 4 & 5, 31
 - Step timing diagram, 17
 - Stepper motor EMC requirements, 28
 - Surge protection, 25
 - Switch settings, 31
 - T
 - Temperature of motor warning, 10
 - Temperature rating of motor cable, 9
 - Temperature, operating, 23
 - Temperature, storage, 23
 - Testing the drive, 32
 - Type 2 series of drives, 1
 - U
 - Unipolar rating, 8
-

