

# A P P E N D I X A

---

---

## *LVD Installation Instructions*

For more information about LVD, see 73/23/EEC and 93/68/EEC, published by the European Economic Community (EEC).

### **Environmental Conditions**

---

#### ***Pollution Degree***

The OEM770X is designed for pollution degree 2.

#### ***Installation Category***

The OEM770X is designed for installation category II.

### **Electrical**

---

#### ***Connecting and Disconnecting Power***

The OEM770X's protective earth connection is provided through its heatsink. You must reliably earth the OEM770X's protective earth connection.

Attach or remove the OEM770X's power connections only while input power is OFF.

The OEM770X's supply voltage is limited to 75 VDC.

#### ***Connecting the Protective Conductor Terminal to Earth***

You must provide a connection from the OEM770X's protective conductor terminal to a reliable earth point.

The protective conductor terminal is marked with a label on the product bearing the following symbol:



*Protective Conductor Terminal Marking*

## LVD Installation Instructions • OEM770X

To connect the protective conductor terminal to earth, complete these steps:

1. Use a ring terminal in combination with a star washer to make good contact with the exposed metal surface surrounding the lower mounting hole on the OEM770X. (The dimension drawing in *Chapter 2 Installation* indicates that the lower mounting hole is surrounded by exposed metal.)
2. Use a VDE approved green/yellow protective conductor terminal wire to reliably earth the protective conductor terminal. Wire gauge must be no thinner than the current-carrying wire in the product's mains supply.
3. Resistance between the protective conductor terminal and earth must be no greater than 0.1 ohm. Use thicker gauge wire if the resistance is too high.

### **Providing a Protective Earth Connection for Motors**

You must provide a connection from the motor to a reliable protective earth. This connection provides a protective earth for the motor contact point. The motor's protective earth connection is important for safety reasons, and *must not be omitted*.

Make connections according to the following instructions and diagram:

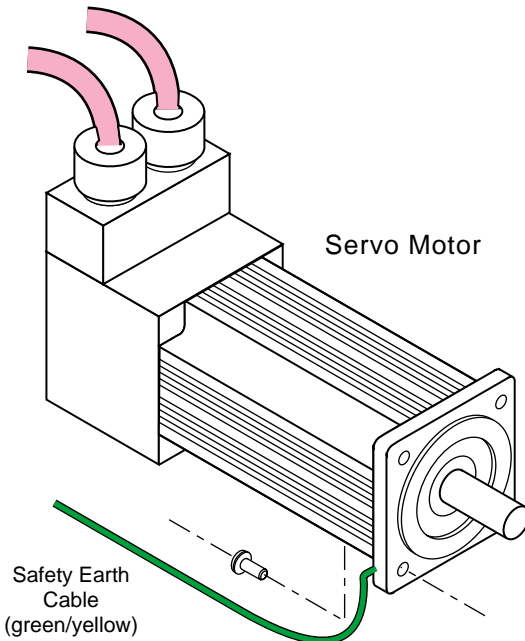

## **OEM770X • LVD Installation Instructions**

1. Use a ring terminal in combination with a star washer and mounting bolt to make good contact with the bare metal surface of the motor's mounting flange.
2. Use a VDE approved green/yellow protective conductor terminal wire to make the connection between the motor and earth. Wire gauge must be no thinner than the current carrying wire in the motor's power cable.
3. Resistance between the motor and earth must be no greater than 0.1 ohm. Use thicker gauge wire if the resistance is too high.

### **MECHANICAL**

#### ***Installing in an Enclosure***

The OEM770X must be installed within an enclosure. The enclosure's interior must not be accessible to the operator. The enclosure should be opened only by skilled or trained service personnel.

#### ***Do Not Operate the OEM770X Without Cover***

The cover provides mechanical support to the circuit assemblies inside.

### **SERVICING THE OEM770X**

#### ***Changing Firmware***

Only skilled or trained personnel should change firmware.

### **THERMAL SAFETY**







#### ***The Motor May Be Hot***

The motor may reach high temperatures during normal operations, and may remain hot after power is removed.

## Table of Graphic Symbols and Warnings

---

The following symbols may appear in this user guide, and may be affixed to the products discussed in this user guide.

Symbol	Description
	Earth Terminal
	Protective Conductor Terminal
	Frame or Chassis Terminal
	Equipotentiality
	Caution, Risk of Electric Shock
	Caution, Refer to Accompanying Text
	Hot Surface