

C H A P T E R ⑥

Power Supply Selection

To choose a power supply for the OEM670/OEM675, you need to answer some important questions.

- How many watts does your system need?
- Will regeneration be a concern ?
- At what voltage should your system operate?
- Should you use a linear power supply or a switching power supply?

The sections in this chapter will help you answer these questions.

A Word About Units

We want a solution for power that is expressed in *watts*. To be consistent with watts, we will express all quantities in SI (metric) units, derived from kilograms, meters, and seconds. The quantities and units we will use are:

<u>QUANTITY</u>	<u>SYMBOL</u>	<u>UNITS</u>
Torque	T	Nm (newton meter)
Shaft Velocity	v	rps (revs per second)
	ω	rad/s ($2\pi v = \omega$)
Shaft Acceleration	a	rps ⁻² (revs per sec ²)
	α	rad/s ⁻² ($2\pi a = \alpha$)
Motor Resistance	Ω	ohms
Torque Constant	k_T	Nm/A
Current	I	A (amps)
Inertia	J	kg-m ²

If you want to use other units, apply conversion factors in the appropriate places.

HOW MUCH POWER DOES YOUR SYSTEM NEED?

The first step in choosing a power supply is to analyze your motion control system, and determine two quantities:

- Peak Power
- Average Power

Peak power is the maximum number of watts the power supply must provide during the most demanding part of the move.

Average power is the number of watts required for a repetitive move, averaged over the entire move cycle, including time spent at rest.

In the sections below, we show several ways to determine how much power your system needs: a calculation method; a graphical method; and an empirical method.

It is not our goal to calculate power *precisely*. A full analysis of power in a servo system can be quite complicated and time consuming. Rather, our goal is to easily arrive at a reasonably accurate *estimate* of power needs, and then use this estimate for power supply decisions.

PEAK POWER—A CALCULATION METHOD

Servo applications vary widely, with many possible move profiles. We will show how to calculate power requirements for the most common move profile, a trapezoidal move.

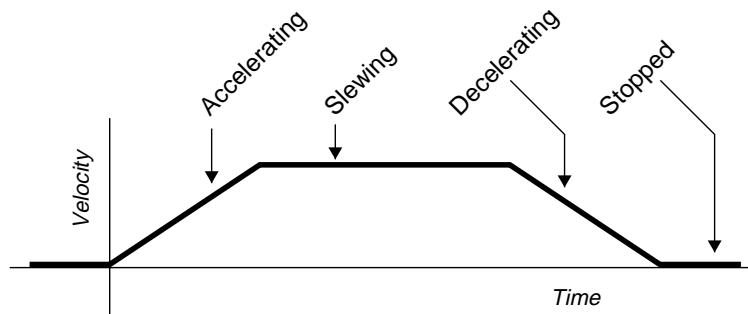

Trapezoidal Move Profile

In the calculation method, we follow these steps:

- ① Calculate power required for copper losses
- ② Calculate shaft power
- ③ Add shaft power and copper losses, for total power
- ④ Add 10% to total power, for miscellaneous losses

Each of these steps will be explained below. To simplify the analysis, we make the following assumptions:

- Equal acceleration and deceleration rates
- Friction is negligible, and can be ignored

Power for Copper Losses

During the acceleration portion of a trapezoidal move, constant current in the motor produces constant torque. With a constant torque applied, the motor accelerates at a constant rate until it reaches slew velocity.

Torque is directly proportional to the current in the motor.

$$T = k_T I, \text{ or } I = \frac{T}{k_T}$$

The proportionality constant, k_T , is called the torque constant, and is determined by the motor's physical parameters.

The current that produces torque flows through the resistance, R , of the motor's copper coils, and causes heat. The power to produce this heat comes from the power supply. (The coil resistance R may change with temperature. When you use the equations that follow, use the resistance of your motor at its actual operating temperature.)

Power converted to heat, rather than useful work, is called a *loss*. The losses resulting from current flowing in the motor's copper coils are called *copper losses*, or *I^2R losses*, so named from the formula used to calculate them:

$$P_{copper} = I^2 R$$

P_{copper} represents power used for copper losses.

© **Power Supply Selection • OEM670/OEM675**

You can calculate copper losses, even if you do not know the motor current I . The following equation uses the relationship between current and torque to express copper losses in terms of torque, resistance, and the torque constant.

$$P_{copper} = I^2 R = \left(\frac{T}{k_T} \right)^2 R$$

Copper losses are shown in the next drawing.

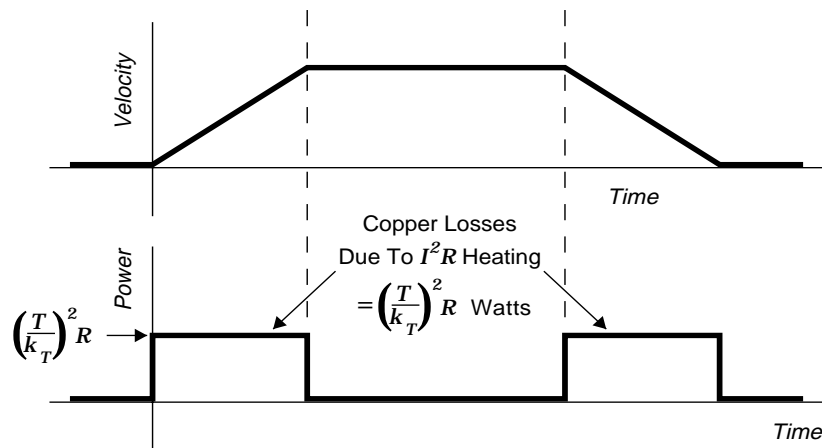

Copper Losses

The supply must deliver power only during acceleration and deceleration. During slew with no friction, there is no torque on the motor shaft, and no motor current—consequently, there are no copper losses

Shaft Power

A motor uses shaft power to accelerate or decelerate a load. The equation for shaft power, the product of torque and shaft velocity, is

$$P_{shaft} = \omega T = 2\pi v T$$

where P_{shaft} is shaft power, in watts.

OEM670/OEM675 • ⑥ Power Supply Selection

The graph for shaft power is shown in the next drawing.

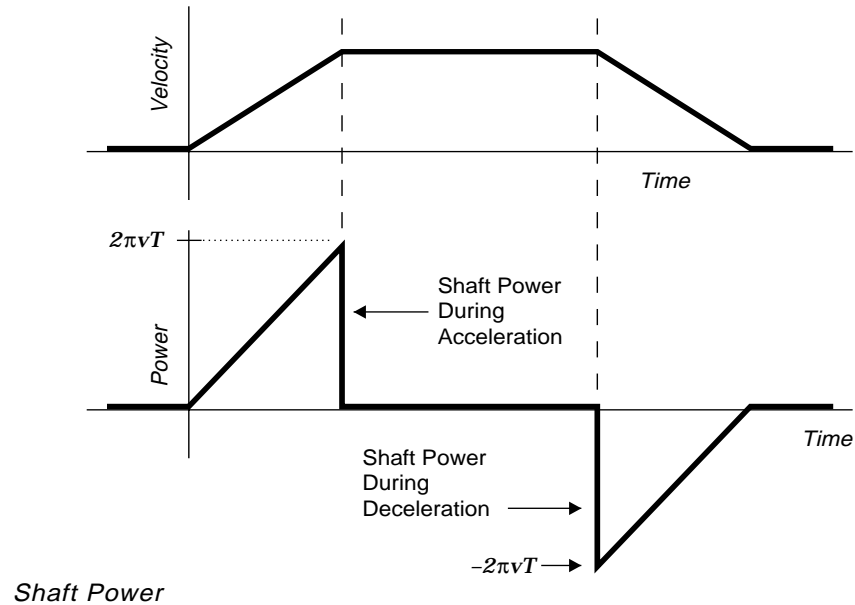

Torque and velocity are both positive during acceleration. Shaft power, therefore, is also positive.

During deceleration, velocity is still positive, but torque is applied in the opposite direction, and thus is negative. Shaft power, then, is *negative* during deceleration. Negative power is *regeneration*—power flows from the motor, and back into the drive. Later in this chapter, we will discuss regeneration in detail.

Total Power

In the next drawing, we have combined the graphs for copper losses and shaft power.

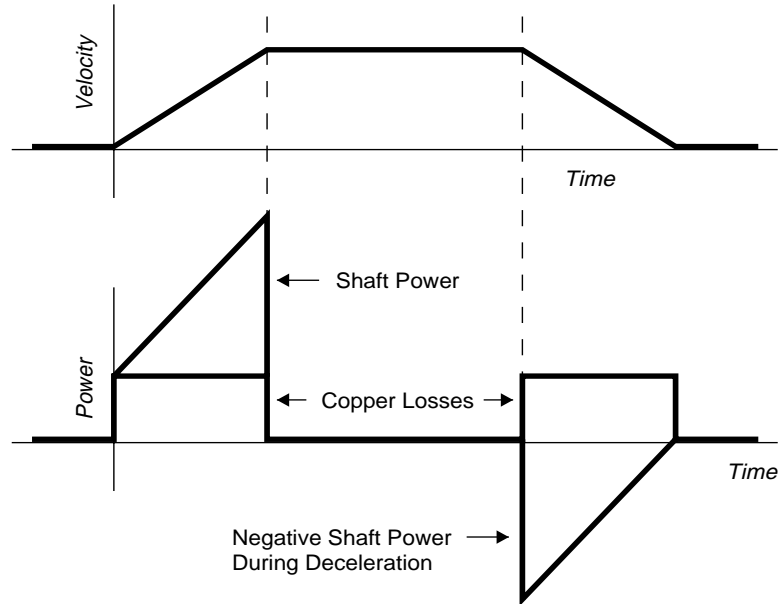

Copper Losses & Shaft Power

To obtain the total power, we can add together copper losses and shaft power. The heavy line in the next drawing shows the total power that the power supply must provide.

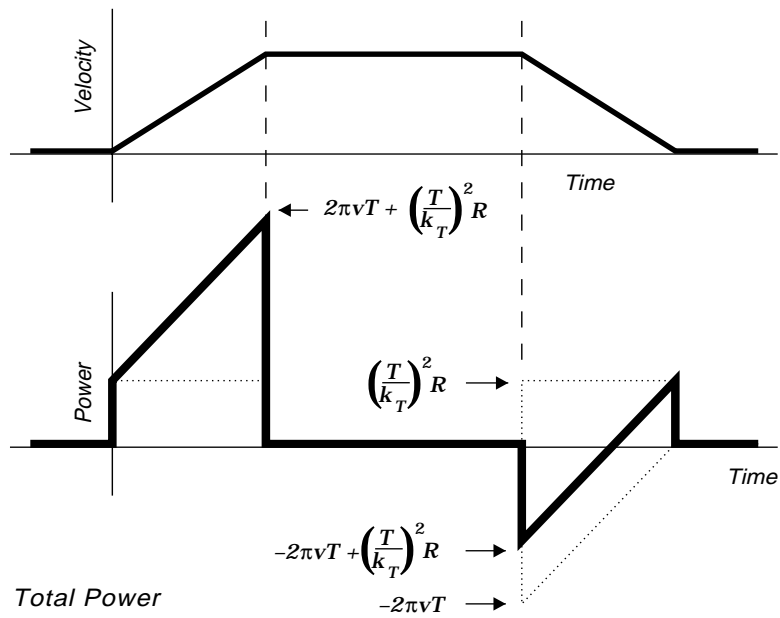

Total Power

OEM670/OEM675 • ⑥ Power Supply Selection

The equation for power, then, at any velocity during acceleration or deceleration, is:

$$P_{total} = P_{shaft} + P_{copper} = 2\pi vT + \left(\frac{T}{k_T}\right)^2 R$$

The first term on the right represents shaft power. The second term represents copper losses.

Notice that power demand increases as velocity increases during acceleration, and reaches a peak just before the motor reaches its slew velocity. The equation for peak power is:

$$P_{peak} = 2\pi v_{slew}T + \left(\frac{T}{k_T}\right)^2 R$$

Estimation Factor

The power equations above show how much power the supply must deliver for shaft power and copper losses. There are other losses, which are usually smaller and less significant, such as:

- Drive Losses
- Core Losses
- Switching Losses

Core losses are dependent on velocity. To approximate their effect, use the power equation from above, and add 10% to it.

$$P = \left[2\pi vT + \left(\frac{T}{k_T}\right)^2 R \right] (1.1)$$

For clarity and simplicity in the rest of this chapter, we will omit the 10% figure that represents miscellaneous losses. If you need more accuracy in your estimate, you should include this estimation factor.

Drive losses are not dependent on velocity. When the motor is at rest, or during slew, drive losses are approximately 5–10W.

Power Supply Current Does Not Equal Motor Current

The equation we have developed represents power that the *power supply* must deliver to the system. This is not the same as *motor power*, or *drive power*. Similarly, current from the power supply will not be the same as current flowing in the motor.

These distinctions can be confusing! To help clarify the situation, think of the equation as an accounting system. All terms on the right side of the equation represent places where power is used in the system: motor heating, shaft power, drive losses, hysteresis, etc. We add up these amounts of power, find the total, and then insist that this total power must have come from the power supply. Therefore, the equation shows how much power the supply must provide for every use on the right side of the equation.

What about Acceleration and Inertia?

To use the equation we have developed, you only need four pieces of information about your system:

T	Torque
v	Velocity
k_T	Motor Torque Constant
R	Motor Resistance

You may be wondering why acceleration, rotor inertia, or load inertia do not appear in the equation, and what effect these parameters have on power requirements.

The answer is that acceleration and inertia *are* in the equation—they are hidden within the values for torque and velocity. Recall that torque is equal to the product of acceleration and inertia.

$$T = \alpha J = 2\pi a J$$

When you analyze your system, you can derive torque and velocity terms based on acceleration requirements, load inertia, and rotor inertia. Acceleration and inertia, therefore, are implicit in the equation we have developed (and are also implied in speed/torque curves for motors).

PEAK POWER—A GRAPHICAL METHOD

Given a speed/torque curve for a particular motor, you can overlay a family of curves that show peak power levels for various moves. To do this, start with the equation for peak power that we developed above. Next, set P equal to a fixed value, and then solve for velocity.

$$v = \frac{P - \left(\frac{T}{k_T}\right)^2 R}{2\pi T}$$

For any given torque, you can determine a velocity such that the peak power required to reach that velocity is equal to P watts. The graphical method is illustrated in the next example.

Example

For the SM231A motor at 75VDC, we wish to determine a curve that shows all of the possible speed/torque combinations that require 300W peak power. So, set $P = 300W$. We then have;

$$v = \frac{300 - \left(\frac{T}{k_T}\right)^2 R}{2\pi T}$$

<i>Torque oz-in (Nm)</i>	<i>Velocity (rps)</i>
75 (0.53)	73
100 (0.71)	45
125 (0.88)	26

For each torque listed in the table, the peak power required to reach the corresponding velocity is 300W.

In the next drawing, we have plotted these values on the speed torque curve for the SM231A motor. We have also plotted a similar curve, corresponding to moves of 200W peak power.

⑥ Power Supply Selection • OEM670/OEM675

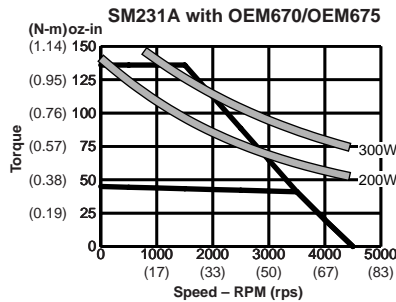

Peak Power Curves: SM231A at 200W and 300W

Any move that falls on the 300W curve will require 300W peak power from the power supply. Moves that lie above the curve will use more torque, a faster velocity, or both, and consequently will need more peak power. Moves that lie below the curve will need less power.

Compumotor's OEM300 Power Module produces 300W peak and 200W continuous. You could use it to power any move on or below the 300W curve. You could use it continuously for any move below the 200W curve.

Compumotor's OEM1000 Power Supply produces 1000W. You could use it to power any move within the speed/torque curve.

OEM670/OEM675 • ⑥ Power Supply Selection

Peak Power Curves for Compumotor Servo Motors

The following drawings show speed/torque curves for SM16, SM23, and NeoMetric servo motors, with peak power curves added.

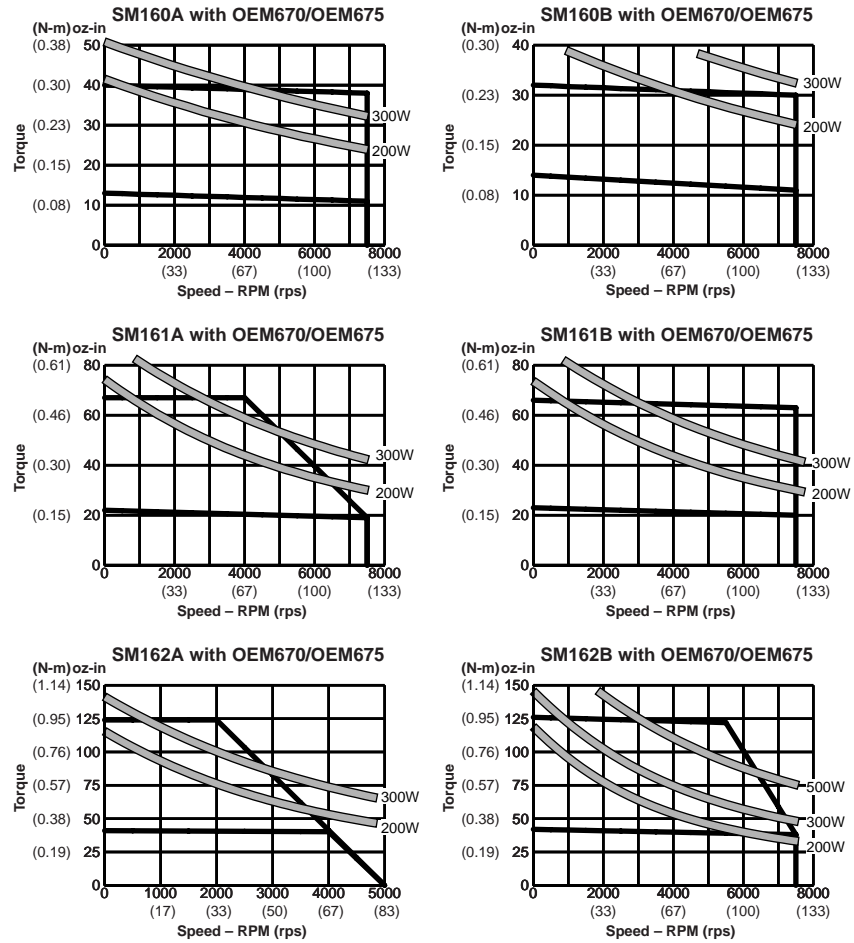

Peak Power Curves: SM Motors, Frame Size 16

⑥ Power Supply Selection • OEM670/OEM675

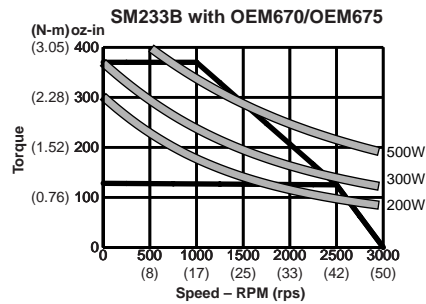
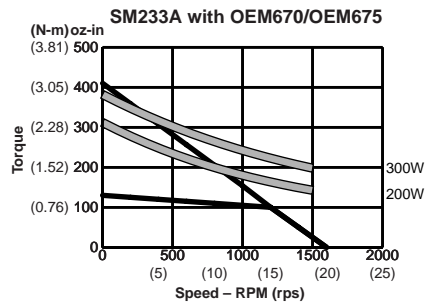
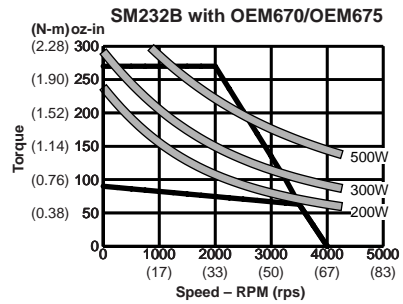
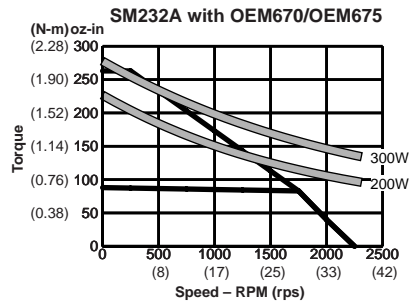
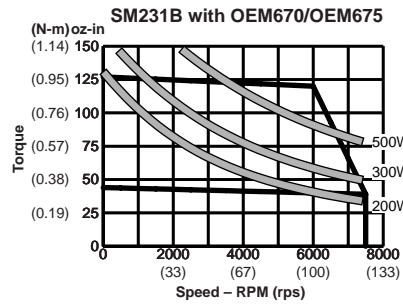
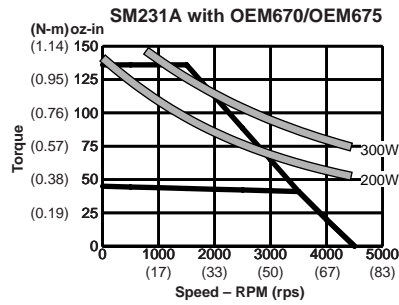
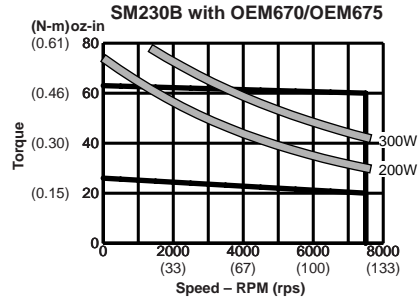
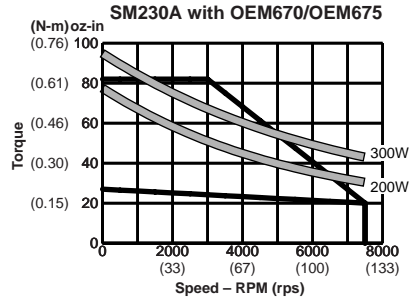

Peak Power Curves: SM Motors, Frame Size 23

OEM670/OEM675 • ⑥ Power Supply Selection

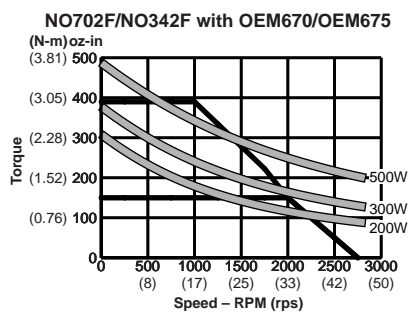
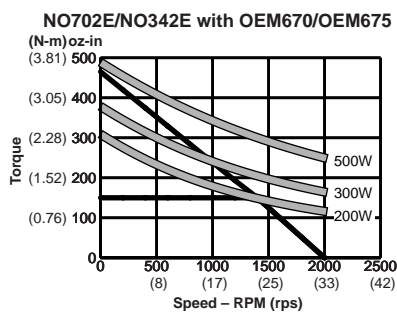
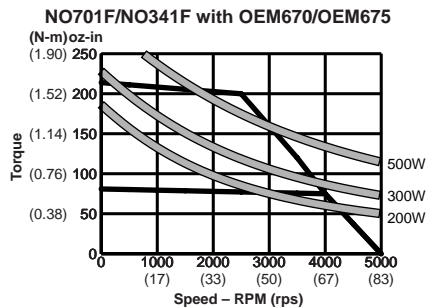
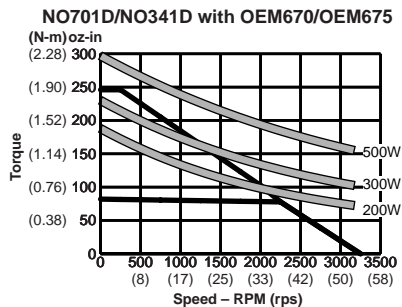

Peak Power Curves: NeoMetric Motors

Example

Use the peak power curves to choose a power supply to use with a system consisting of an OEM675 with an SM233B motor. The motor must accelerate with a torque of 200 oz-in (1.52 Nm), until it reaches a velocity of 1,500 rpm (25 rps). It then slews at constant velocity until it decelerates.

From the peak power curves, observe that this move requires approximately 300W peak power. Choose a power supply that provides at least 330W peak to accomplish this move. (330W includes an extra 10% for miscellaneous losses.)

Example

A system must make a trapezoidal move, and reach 2,000 rpm (33.3 rps) at a torque of 125 oz-in (0.88 Nm). Which size 23 motor requires the smallest power supply to make this move?

From the peak power curves:

<u>Motor</u>	<u>Peak Power</u>	<u>Peak + 10%</u>
SM230A	n/a	n/a
SM230B	n/a	n/a
SM231A	340W	374W
SM231B	365W	401W
SM232A	n/a	n/a
SM232B	240W	264W
SM233A	n/a	n/a
SM233B	220W	242W

This move is beyond the speed/torque range of four motors. Of the remaining motors, the SM233B requires a 242W power supply to make the move. The other motors need larger power supplies.

FRICTION, GRAVITY, AND DIFFERENT MOVE PROFILES

The techniques we have discussed so far apply to trapezoidal moves with negligible friction. Below, we will briefly mention some salient points about other types of moves. If your system has moves similar to one of these, apply the techniques developed above to your application.

Friction

The presence of friction requires additional torque to overcome the friction. We will consider Coulomb friction in a trapezoidal move. (Coulomb friction does not change with velocity. Viscous friction, which *does* depend on velocity, is much more difficult to analyze.)

During acceleration, total torque is equal to the torque required for acceleration plus the torque required to overcome friction.

$$T_t = T_a + T_f$$

where

$$\begin{aligned} T_t &= \text{Total Torque} \\ T_a &= \text{Acceleration Torque} \\ T_f &= \text{Friction Torque} \end{aligned}$$

The next drawing illustrates how friction affects a system.

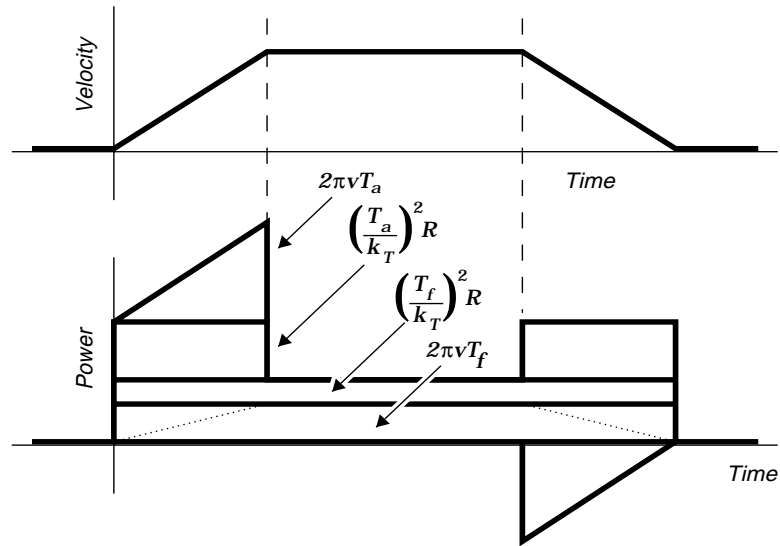

Friction

Observe that friction adds additional plateaus to the drawing. The actual shape of the plateau due to frictional shaft power is shown by the dotted lines. For simplicity, we approximate the shape with a rectangle.

The equation for peak power becomes

$$P_{peak} = 2\pi v (T_a + T_f) + \left(\frac{T_a + T_f}{k_T}\right)^2 R$$

The power supply must also provide power while the motor is slewing at constant velocity. The equation for power during slew is:

$$P_{slew} = 2\pi v_{slew} T_f + \left(\frac{T_f}{k_T} \right)^2 R$$

You can use the peak power curves (discussed in the previous section) to predict the peak power and slew power that the power supply must provide. Be sure that you include the friction torque in the appropriate places, however. The next example illustrates this.

Example

Determine peak power and slew power that an SM232B motor will require. Acceleration torque is 100 oz-in (0.71 Nm). Friction torque is 50 oz-in (0.35 Nm). The slew velocity is 2,000 rpm (33 rps).

Total torque during acceleration is 150 oz-in (1.06 Nm), the sum of acceleration and friction torque. On the curves, the intersection of 150 oz-in and 2,000 rpm lies on the 300W line.

During slew, the only torque present is friction torque. At 50 oz-in and 2,000 rpm, the curves show that 80W is required.

The power supply must be capable of providing at least 330W peak and 88W continuous power (these values include a 10% estimation factor).

Gravity

We can distinguish two distinct situations when gravity is involved in an application.

- Lifting a load against gravity
- Lowering a load with gravity

These situations must be analyzed separately.

When your system lifts a load, gravity imposes a force downward. The motor must exert an additional torque to counteract this force. This is similar to a system that has friction, where the motor must exert an additional torque to overcome the friction. One possible difference can occur if the motor must provide holding torque while the load is stationary, to prevent the load from moving downward. In this case, the

supply must provide power for the copper losses due to the holding torque, even when the motor is not moving.

The analysis for lowering a load can be much more complicated. The basic power equation can still be used, but you must take care to use the proper algebraic sign for the various torques, forces, velocities, etc. A full analysis of the calculation method is beyond the scope of this text. The easiest way to determine your system's power needs may be the empirical method, discussed in the next section.

As an example of the complexity of the calculation involved, consider just one part of the move profile—acceleration from rest, with the load moving downward. Depending upon whether the acceleration is faster, slower, or equal to gravitational acceleration, net power can be positive, negative (regeneration), or even zero! Other parts of the move profile are equally complicated.

Other Move Profiles

Many other move profiles and application conditions are possible. For example, moves can be sinusoidal, s-curve, or random, with or without friction, with or without gravity.

To calculate power needs for moves such as these, you may be able to follow the methods we have developed above, and modify the equations to suit your application. Or, you may need to use the empirical method, presented below.

POWER REQUIREMENTS—AN EMPIRICAL METHOD

You can use an empirical approach to measure the voltage and current going from a power supply to an OEM670/OEM675, and directly determine your system's power requirements.

You will need the following equipment:

- DC Current Probe
- Oscilloscope
- Large Power Supply

This method also requires that you make a prototype of your system.

Prototype Your System

Make a working prototype of your system. For the power supply, temporarily use a large power supply that is capable of providing enough power for all the moves your system makes. The temporary power supply should operate at the same voltage at which you intend your final system to run. Once you determine the power requirements, you can replace the temporary power supply with a permanent one.

Measure Current

Connect a current probe to one channel of an oscilloscope. (Connect the probe in the correct direction. With the motor at rest, the probe should measure *positive* current.) Measure current going from the power supply to the OEM670/OEM675 while your system performs its moves under actual operating conditions. Current going from the OEM670/OEM675 to the motor is not relevant in this procedure; you do not need to measure it.

Your current probe must be of the type that connects to an oscilloscope, and is fast enough to show current variations (such as a Tektronix A6302 Current Probe and AM 503 Current Probe Amplifier). The current probe in a digital multimeter will not work in this situation, nor will an AC current probe.

Connect an oscilloscope probe to the second channel of the oscilloscope, and use it to monitor power supply bus voltage.

OEM670/OEM675 • ⑥ Power Supply Selection

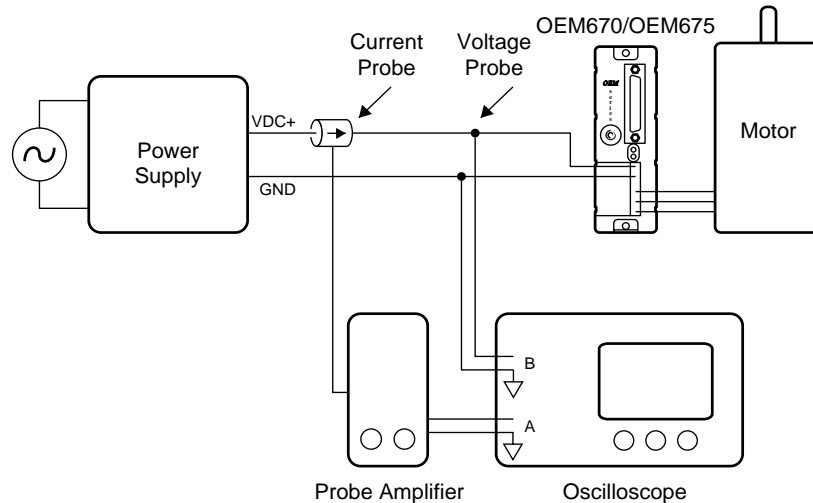

Setup for Current Measurement

The bus voltage should drop no more than 10% during peak power events. If it drops more than 10%, use a larger power supply.

Determine Power Needs

At any moment the power used by your system is

$$P = V_{supply} I_{supply}$$

When the current is positive, current flows from the supply to the drive, and the supply delivers power to your system. When current is negative, the system is regenerating—power flows from your system, and back into the supply.

To determine the peak power that the supply must deliver, measure the highest current (as seen on the oscilloscope screen). Substitute this current in the power equation, to get

$$P_{peak} = V_{supply} I_{peak}$$

Once you know the peak power that your system demands, you can select a supply that can deliver enough power.

AVERAGE POWER CALCULATIONS

Many power supplies have a peak power rating and an average power rating. The peak power may be much higher than the average power rating.

For example, the OEM300 Power Module can deliver 300W peak for 30 seconds, at a 10% duty cycle. It can deliver 200W continuously.

To determine the average power in your system, calculate the area under the graph of power, and multiply by the repetition frequency.

Example

Consider a trapezoidal move with acceleration a , velocity v , and repetition frequency f_{rep} . Ignore friction, and assume that regeneration provides power for deceleration. Therefore, the power supply only delivers power during acceleration.

The average power is

$$P_{avg} = f_{rep} \frac{v}{a} \left[\frac{1}{2} (2\pi v T) + \left(\frac{T}{k_T} \right)^2 R \right]$$

If your system needs power to decelerate, you should add a term to the equation that represents power needed to decelerate, and include this power in the average.

REGENERATION

At certain times during a move, particularly during deceleration or while lowering a load, energy can be transferred from the motor and load, and back to the power supply. This is called *regeneration*.

The following sections will describe methods to calculate the power and energy that regeneration can produce during deceleration in a trapezoidal move. You can use this information to help you select a power supply that can deal with regenerated energy.

POWER FLOW DURING DECELERATION

In the trapezoidal moves we have analyzed, we used the convention that torque and velocity are positive during acceleration. During deceleration, however, torque is applied in the opposite direction. Therefore, torque is negative, and shaft power, the product of torque and shaft velocity, is also negative.

$$P_{shaft} = \omega(-T) = 2\pi v(-T)$$

Negative shaft power means that power flows from the motor back to the drive. Does this mean that deceleration always causes regeneration? Not necessarily. Current must flow in the motor to produce the negative torque. The heat that this current produces is proportional to the *square* of the torque. Copper losses, therefore, are always positive.

$$P_{copper} = \left(\frac{-T}{k_T}\right)^2 R$$

The total power during deceleration, then, is the sum of shaft power and copper losses.

$$P_{decel} = -2\pi vT + \left(\frac{-T}{k_T}\right)^2 R$$

If the magnitude of the first term is larger than the magnitude of the second term, then the net power is negative—power will flow from the system, and back into the power supply. When the second term is larger than the first, the power supply must provide power for deceleration.

ENERGY DURING REGENERATION

The power supply must be capable of absorbing or dissipating energy that flows into it during regeneration. The amount of energy is related to the power that we discussed above.

Recall from physics that the *joule* is the unit of energy in the

© Power Supply Selection • OEM670/OEM675

SI system, and that power is the rate of energy flow. One watt is equal to an energy flow of one joule per second.

$$1 \text{ watt} = 1 \text{ joule/second}$$

Energy is also the integral of power. Therefore, you can determine the total energy produced during deceleration by finding the area under the peak power curve. The next drawing shows this area, for a situation where copper losses are small, and shaft power is large.

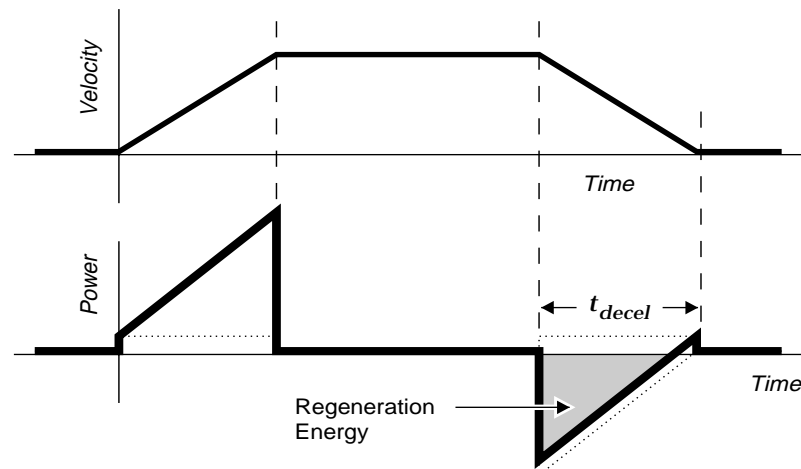

Regeneration with Low Torque

To approximate the total energy from regeneration, find the area of the triangle representing shaft power. You can ignore the copper losses, because they are small.

$$E_{regen} = \frac{1}{2} \cdot \text{base} \cdot \text{height} = \frac{1}{2} (-2\pi vT)(t_{decel}), \text{ in joules}$$

The next drawing shows the deceleration portion of a move that uses a higher torque to decelerate the motor. Consequently, the copper losses are greater.

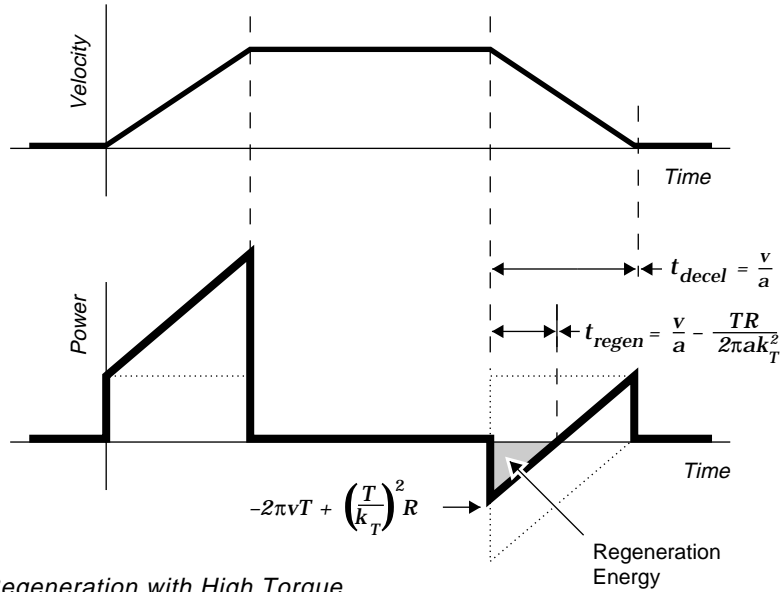

If you ignore copper losses when you calculate energy from regeneration in this type of situation, the answer will be much larger than the actual energy produced. To accurately calculate the energy, use the next equation to find the area of the regeneration triangle.

$$E_{regen} = -\frac{1}{2} \left[2\pi vT - \left(\frac{T}{k_T} \right)^2 R \right] \left[\frac{v}{a} - \frac{TR}{2\pi a k_T^2} \right], \text{ in joules}$$

In this equation, v is the slow velocity, and a is the deceleration rate.

⑥ Power Supply Selection • OEM670/OEM675

REGENERATION CURVES

In the following version of the regeneration equation:

$$v = \frac{P + \left(\frac{T}{k_T}\right)^2 R}{2\pi T}$$

if we set power equal to a specific value, and solve for velocity at various torques, we can plot a family of curves that represent peak regeneration watts. We have done this below for Compumotor servo motors.

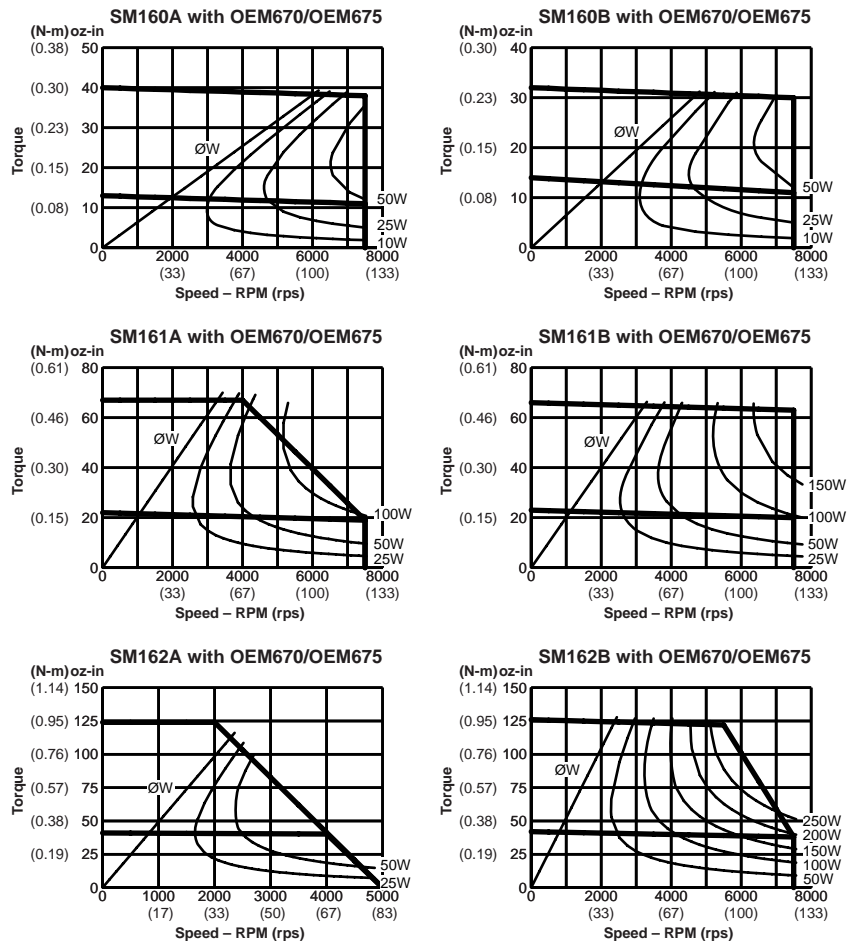

Peak Regeneration Curves: SM Motors, Frame Size 16

OEM670/OEM675 • ⑥ Power Supply Selection

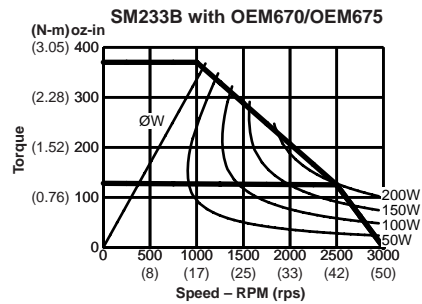
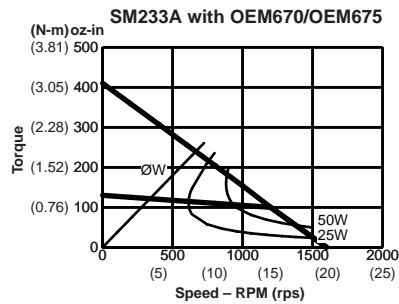
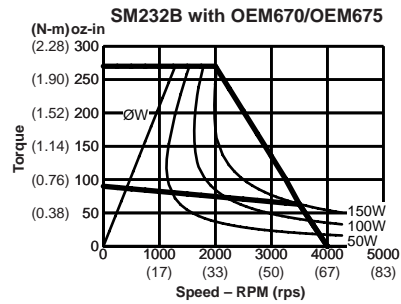
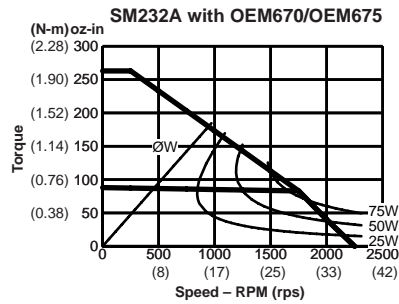
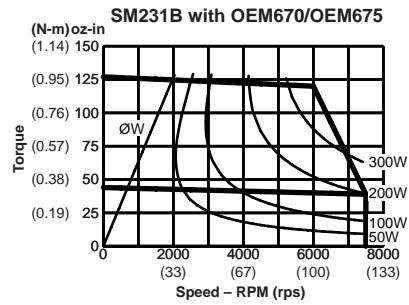
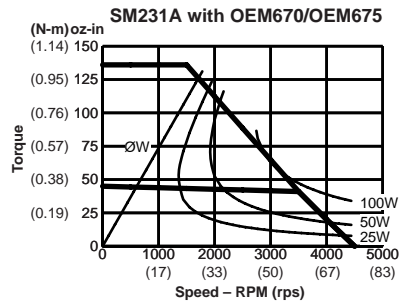
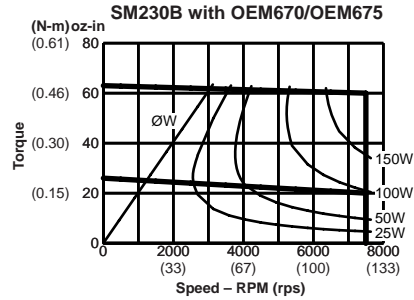
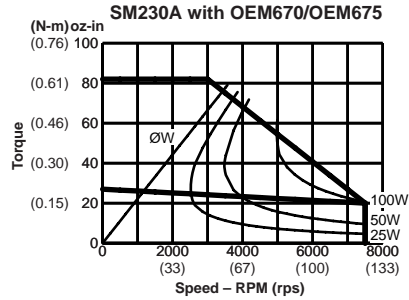

Peak Regeneration Curves: SM Motors, Frame Size 23

⑥ Power Supply Selection • OEM670/OEM675

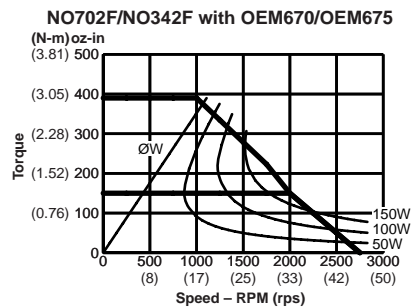
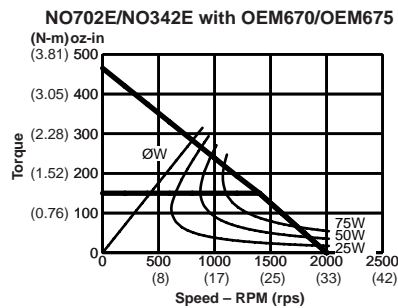
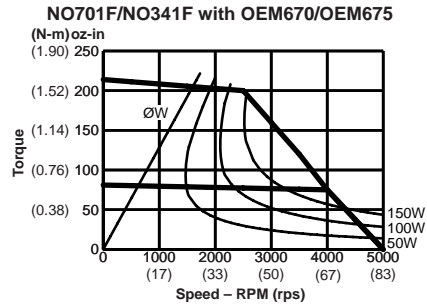
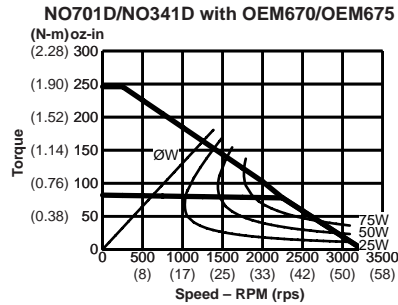

Peak Regeneration Curves: NeoMetric Motors

On each of these charts, there is a straight line corresponding to zero watts. This is where

$$2\pi vT = \left(\frac{T}{k_T} \right)^2 R$$

In areas to the left of this line, copper losses are always greater than shaft power, and the power supply must always provide power. In other words, for any move to the left of this line, the power supply will not receive regeneration energy from the system, because copper losses will be greater than negative shaft power.

Example

An SM232B motor performs a trapezoidal move. It slews at 50 rps, and decelerates at 100 rps⁻² with a torque of 75 oz-in (0.53 Nm). Does the power supply receive regenerated energy? If so, how much? The motor has a torque constant $k_T = 0.169$ Nm/A, and a resistance $R = 2.01$ ohms.

Using the regeneration equation,

$$\begin{aligned}
 E_{regen} &= \frac{1}{2} \left[2\pi v T - \left(\frac{T}{k_T} \right)^2 R \right] \left[\frac{v}{a} - \frac{TR}{2\pi a k_T^2} \right] \\
 &= \frac{1}{2} \left[2\pi(50)(0.53) - \left(\frac{0.53}{0.169} \right)^2 2.01 \right] \left[\frac{50}{100} - \frac{(0.53)2.01}{2\pi(100)(0.169)^2} \right] \\
 &= \frac{1}{2} [166.5 - 19.8] [0.5 - 0.06] \\
 &= \frac{1}{2} [146.7 \text{ watts}] [0.44 \text{ seconds}] \\
 &= 32.3 \text{ joules}
 \end{aligned}$$

At the moment deceleration began, the peak regenerated shaft power was 166.5W, and copper losses were 19.8W. The peak regeneration power was therefore 146.7W, which you can also read directly from the chart for the SM232B motor. To determine regeneration energy (joules), however, you need to perform the calculation.

The last term in the equation shows that total deceleration time (v/a) was 0.5 seconds. The power supply received regenerated energy for the first 0.44 seconds, and had to supply power for the final 0.6 seconds.

WHAT VOLTAGE DO YOU NEED?

The OEM670/OEM675 uses the DC power supply voltage as the supply voltage for the motor. The motor's performance depends on the voltage at which it runs. Therefore, the power supply voltage you choose will affect motor performance. We will use Compumotor servo motors as examples to illustrate this, but the points presented below apply to any servo motor.

Because the OEM670/OEM675 accepts such a wide range of input voltage (24 – 75VDC), you have several options for choosing a power supply voltage. These options are explained below.

MATCH THE POWER SUPPLY TO THE MOTOR

Manufacturers wind servo motors for optimum performance at a specific voltage. They publish speed/torque curves measured at that voltage. If you select a motor because you need the performance shown in the curves, choose a power supply that produces at least as much voltage as that for which the motor was designed.

For example, Compumotor servo motors specified in this user guide are wound for 75VDC operation. The speed/torque curves were measured with a 75VDC power supply. If you want the full performance shown in the curves, use a power supply that operates at 75 volts.

USE AVAILABLE POWER, AND CUSTOM WIND A MOTOR

In many machines, the motion control system is but one component among many in the entire machine. Power may be available from a large power supply that runs other parts of the machine. We designed the OEM670/OEM675 so that you can take advantage of available power.

If power is available, but at a voltage lower than specified for the motor you have chosen, you can contact the manufacturer to see if the motor can be made with the voltage rating you need. Motor manufacturers can design a motor's windings so that it can have similar performance characteristics at different voltages.

For example, suppose you decide to use the SM231A motor. You want to make moves that lie within the 75VDC speed/torque curve, but you only have 48VDC available. If you cannot get the performance you need from the standard motor at 48VDC, you should call Compumotor. We can make the motor with a special winding to obtain performance similar to that shown in the 75VDC speed/torque curve, but at 48VDC.

USE AVAILABLE POWER AND AN AVAILABLE MOTOR

You can use a power supply whose voltage is less than the voltage at which your motor's speed/torque curve was specified. The motor will not be able to perform the full range of moves shown on the speed/torque curve, however.

OEM670/OEM675 • ⑥ Power Supply Selection

The next drawing shows how varying the power supply voltage affects a motor's speed/torque curve. The speed/torque curve can be approximated by two asymptotes, labeled A_1 and A_2 in the curve on the left. A_1 is not affected by voltage changes, but A_2 is. As the voltage is decreased, A_2 will shift to the left. The slope of A_2 will not change.

A_2 will move a distance proportional to the decrease in voltage. If the voltage is cut in half, A_2 will move halfway to the origin. If voltage is reduced by two thirds, A_2 will move two thirds of the way toward the origin.

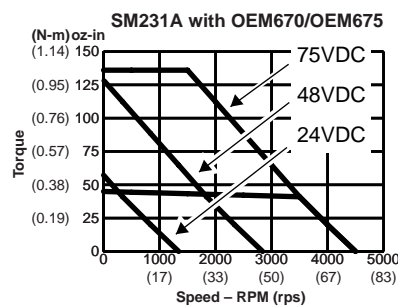
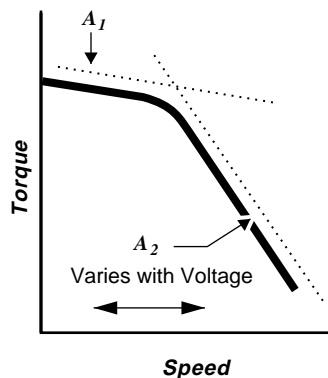

Voltage Affects the Speed/Torque Curve

To illustrate how voltage affects performance for a specific motor, the drawing shows the speed/torque curve for the SM231A motor at 75VDC, 48VDC, and 24VDC.

POWER SUPPLY CHOICES

If you have worked through the previous sections, then by this point you have:

- Determined how much power your system needs.
- Determined whether regeneration is a concern.
- Selected a power supply voltage.

Armed with this information, you are now ready to choose a power supply! You have three main choices:

⑥ *Power Supply Selection • OEM670/OEM675*

- Linear Unregulated Power Supply (OEM1000)
- Switching Power Supply
- OEM300 Power Module

In the following sections, we will explain the advantages and disadvantages of linear and switching supplies. We will also present information about Compumotor's OEM300 Power Module and OEM1000 Power Supply.

LINEAR POWER SUPPLY

The simplest linear power supply consists of a transformer, bridge rectifier, and capacitor. The transformer changes the level of the AC input voltage. Diodes in the rectifier change the AC to DC. The capacitor filters the DC, and stores energy. Such linear supplies are unregulated.

Some models have a fuse to provide overcurrent protection. To improve the transient response, the single output capacitor can be replaced by combinations of capacitors and inductors.

Compumotor's OEM1000 is a linear power supply.

Advantages of Linear Power Supplies

- SIMPLICITY** – Linear supplies are simple, robust, and repairable. They have very few parts. Once the supply is working, it usually keeps working for a long time. If a part fails, diagnosing the failure is straightforward, and the part can be replaced.
- LOW COST** – In many applications, a linear supply costs less than a switching supply. (This depends upon power level and number of units.)
- LOW NOISE** – Linear supplies are virtually free of electrical noise, and give excellent results in noise-sensitive applications.

Disadvantages of Linear Power Supplies

- POOR LINE REGULATION** – If the input line voltage rises or falls, the power supply's output voltage will also rise or fall.

- ❑ **POOR LOAD REGULATION** – When the load uses more power, the power supply's output voltage may drop.
- ❑ **VOLTAGE RIPPLE** – Large ripple voltage in the output requires a relatively large output capacitor for smoothing.
- ❑ **LARGE SIZE** – Compared to a switching supply of the same power level, a linear supply is larger, heavier, and takes up more space.
- ❑ **LOW EFFICIENCY** – The linear supply suffers losses in the transformer and other components. This dissipation can result in heat and higher operating temperatures.
- ❑ **SLOW TRANSIENT RESPONSE** – The linear supply may not be capable of keeping up with the rapidly changing load requirements of some servo systems. Designing a linear supply for a high performance system can be quite complex.

Regeneration and Linear Power Supplies

Dealing with regeneration is simpler with linear supplies than with switching supplies. The linear supply's transformer and rectifier will continue to operate during regeneration.

During regeneration, the supply's capacitors will absorb energy from the load. As the energy is stored in the capacitors, the supply's output voltage will rise. If it goes higher than the threshold of 90VDC, the OEM670/OEM675's over-voltage protection will disable the drive. To avoid overvoltage shutdowns, you can use larger capacitors to store more energy, or use a power supply that operates at a lower bus voltage.

SWITCHING POWER SUPPLY

A switching power supply takes an AC input voltage at power line frequency, and uses switching transistors to increase the frequency. Various techniques are used to modify the high frequency voltage and obtain the desired DC output voltage. The chief advantage of operating at higher frequency is that many components, particularly transformers and capacitors, can be much smaller, and operate more efficiently.

© *Power Supply Selection • OEM670/OEM675*

A switching power supply is regulated. It actively monitors the input line voltage, and keeps its output voltage constant, even when the input voltage varies. If the load demands more power, the supply will increase its output current, but its output voltage will stay at a constant level.

Advantages of Switching Power Supplies

- ❑ **REGULATION** – The supply will try to keep its output at a constant voltage, regardless of line or load variations. (There are limitations on how well it can do this.)
- ❑ **SMALL VOLTAGE RIPPLE** – The output voltage ripple is small, and at a high frequency. Therefore, a relatively smaller output capacitor can be used for smoothing.
- ❑ **SMALL SIZE** – A switching supply will be much smaller than a linear supply of the same power rating.
- ❑ **EFFICIENCY** – Switching supplies are efficient—they dissipate less power as heat than linear supplies.
- ❑ **FAST TRANSIENT RESPONSE** – Because a switching supply monitors its output, it can quickly adapt its performance to provide changing amounts of power for changing load conditions. (Power supply transient response depends upon the supply's design.)

Disadvantages of Switching Power Supplies

- ❑ **HIGH COST** – In most applications, a switching supply will cost more than a linear supply. (Depends upon power level and number of units.)
- ❑ **ELECTRICAL NOISE** – Switching supplies produce electrical noise, which may be transmitted to load equipment and power lines. They may not be suitable for noise-sensitive applications.
- ❑ **LESS RELIABLE** – Switching supplies are much more complex than linear supplies. More components means that more things can go wrong. Consequently, the time before failure may be shorter for switching supplies.
- ❑ **LESS REPAIRABLE** – If a switching supply fails, it usually can only be repaired by its manufacturer. The

user probably cannot repair it, and may need to replace the entire unit.

Regeneration and Switching Power Supplies

Regenerated energy flowing from the load to a switching supply may cause the supply to behave erratically and unpredictably. Accommodating regeneration is more difficult with a switching supply than with a linear supply.

You may need to install a *blocking diode* if regeneration causes problems with your switching supply. The next drawing shows where the diode should be positioned.

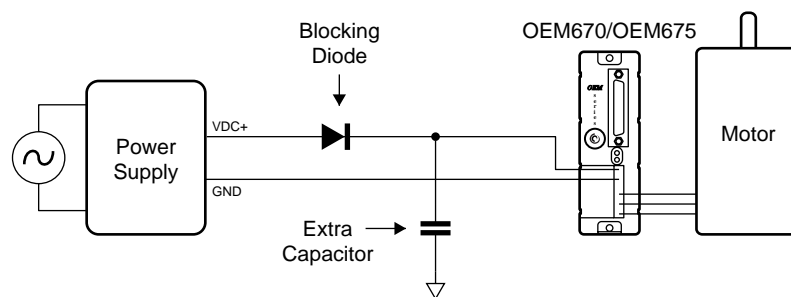

Blocking Diode with Extra Capacitor

The blocking diode will prevent regenerated energy from entering the power supply. This energy *must* go somewhere. If it is not absorbed by the supply, it will charge up the drive's internal capacitors, and cause an overvoltage fault. (In a vertical application, it may damage the drive.)

The drawing above shows one possibility for removing regenerated energy. You can install extra capacitors on the power bus, and allow the energy to charge up the capacitors.

The next drawing shows another possibility for removing regenerated energy. You can install a power dump resistor, and circuitry to monitor the voltage on the power bus.

⑥ **Power Supply Selection • OEM670/OEM675**

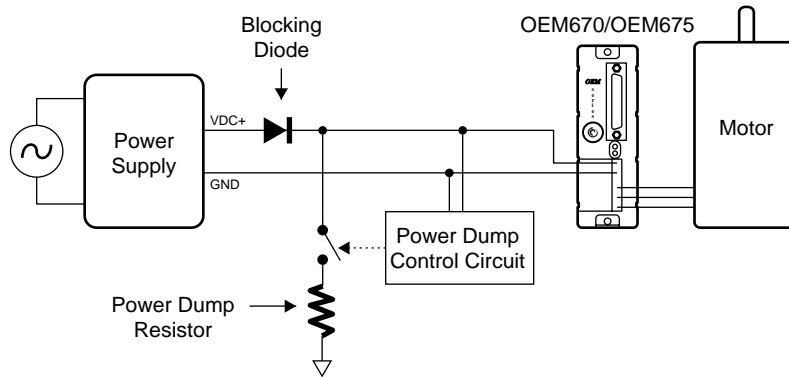

Blocking Diode with Power Dump

Design the circuit so that when regeneration causes a voltage rise, the power dump will turn on and dissipate regenerated energy in the resistor.

OEM300 POWER MODULE

The OEM300 Power Module is a Compumotor product that contains a switching power supply, and several additional circuits that make it an ideal power supply for many servo applications. Its features are summarized below. For additional information, contact Compumotor at 800-358-9070, and request a copy of the OEM300 User Guide.

Power Supply

The switching power supply in the OEM300 has characteristics that are highly compatible with OEM Series Servo Drives and microstepping drives. It can provide 300W peak/200W continuous power, at 4.0A/2.7A, respectively. The transient response of the OEM300 is matched to that of OEM Series drives.

Power Dump

The OEM300 contains a power dump circuit that turns on at 85VDC. The power dump can dissipate as much as 400 joules of energy, at a peak dissipation rate of 722.5 watts.

Short Circuit Protection

The OEM300 will shut down its output if its current exceeds 9 amps.

Overtemperature Protection

An internal temperature sensor will shut down the OEM300 if its temperature reaches 60°C (140°F).

Overvoltage Protection

The OEM300 will shut down its output if an overvoltage condition lasts longer than 0.5 seconds.

POWERING MULTIPLE AXES

So far in this chapter, we have presented several methods for choosing a power supply for a single axis system—one drive and one motor. You can also use a supply to provide power to multiple axes.

To choose a power supply for multiple axis operation, the first step is to determine the power each individual axis requires, using any of the methods we presented above.

Next, determine how the power requirement of each axis relates, in time, to the other axes. There are two possibilities: each axis moves independently; or, the various axes move in a coordinated way, with the motion of each axis depending upon the other axes.

For independent moves, the largest power demand will occur if all axes simultaneously reach their peak power points. Choose a power supply that can provide enough power for this peak demand.

For dependent moves, find the times when the maximum power is required. Add together the power requirements for each axis at these times, to find the peak power requirement. Choose a power supply that can satisfy the peak requirement.

⑥ *Power Supply Selection • OEM670/OEM675*