

# CHAPTER ③

## Specifications

Complete specifications for the OEM670X/675X Drive are listed in the following pages.

Specifications are also listed for Compumotor SM and NeoMetric Series servo motors, along with speed/torque curves and dimensions for the motors.

The motors are described by the following numbering system:

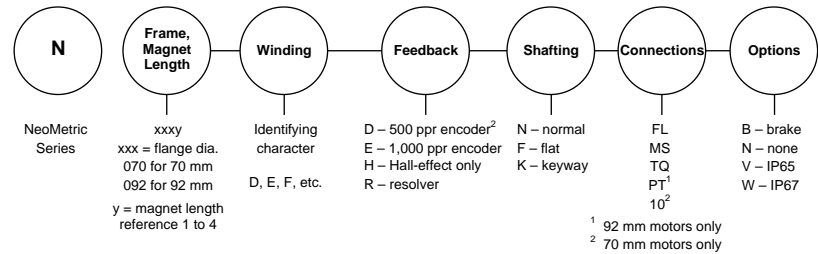
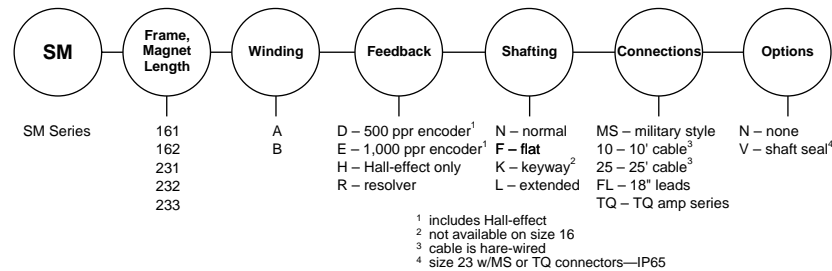

The motors are equipped with Hall effect outputs for commutation feedback. Each motor has an encoder for feedback to the controller. The motors are available with NEMA flanges for compatibility with standard X-Y stages and gear boxes.

Encoder specifications and pinouts are listed after the motor specifications.

③ Specifications • OEM670X/675X

Specifications: OEM670X/675X Controller/Drive

<b>OEM670X/675X Drive – Specifications</b>		
<b>POWER INPUT</b>		
	Voltage	24-75VDC
	Current	Ø-12 amps
<b>POWER OUTPUT—MOTOR</b>		
	Peak Current	12A (approx. 2 sec maximum duration at 45°C ambient temperature. See <i>Current Foldback</i> for details)
	Continuous Current	6A
	Voltage	90VDC maximum
	Peak Power	840W (1.1 hp) (@75V supply voltage)
	Continuous Power	420W (0.56 hp)
	Switching Frequency	20 kHz
	Bandwidth	2 kHz typical (dependent on motor)
	Transconductance	1 volt = 1.2 amp
	Commutation	120° Hall Effect Sensors for Six-State Commutation Method, or Brushed DC Motor
	Short Circuit Protected	Yes
<b>POWER OUTPUT—HALL EFFECT SENSORS</b>		
	Voltage	+5VDC ± 0.5VDC
	Current	50 mA (maximum)
	Short Circuit Protected	NO
<b>PERFORMANCE</b>		
	Position Range	±1,073,741,823
	Velocity Range	0.01 to 200 rev/s
	Acceleration Range	0.01 to 9999 rev/s <sup>2</sup>
	Velocity Accuracy	±0.02% of maximum rate
	Velocity Repeatability	±0.02% of set rate
<b>INPUTS</b>		
	General Purpose Inputs	5 user defined inputs
	Limit Inputs	2 hardware limits
	Enable Input	Active LOW: Ø-0.8V @ 2mA When disabled: Internal 2.49 KΩ pullup resistor to +5VDC
	Encoder	2-phase differential (recommended) or single ended (+5VDC TTL compatible). 960 kHz maximum frequency.
<b>HALL INPUTS</b>		
	Low State	Ø-0.8V
	High State	Internal 1 KΩ pullup resistor to +5V
	Input Frequency	Ø-2 kHz maximum

<b>OEM670X/675X Drive – Specifications (continued)</b>		
<b>OUTPUTS</b>		
General Purpose	2 user defined general purpose outputs	
Fault Output	Active HIGH: open collector output	
	Inactive LOW: $\emptyset$ -0.4VDC at $\emptyset$ -20 mA	
Current Monitor	-10V to +10V analog voltage	
	Scale: 1V corresponds to 1.2A output	
	Output Impedance: 10 K $\Omega$	
LEDs	GREEN = power; RED = various faults	
<b>DIGITAL SERVO LOOP</b>		
Update Time	266 microseconds	
Output	12 bit DAC	
Servo Tuning	RS232C command interface	
Tuning Parameters	PID with digital filter	
<b>RS232C Interface</b>		
Connections	3-wire connection (Rx, Tx, and GND)	
Maximum Daisy Chain	255 units on daisy chain	
Address Settings	Via # command	
Parameters	9600 baud; 1 stop, 8 data bits; no parity	
<b>PROTECTIVE CIRCUITS</b>		
Short Circuit	Turns off outputs to motor; latched	
Over Temperature	55°C $\pm$ 5°C trip temperature; latched	
Overvoltage	95V $\pm$ 5V trip voltage; latched	
Undervoltage	21.5V maximum; not latched	
Current Foldback	Configurable with 3 resistors	
<b>MOTOR CHARACTERISTICS</b>		
Minimum Inductance	50 $\mu$ H (micro Henrys)	
Minimum Resistance	0.25 $\Omega$	
Loop Gain Adjustment	Configurable with one resistor	
<b>TEMPERATURE</b>		
Minimum Temperature	$\emptyset$ °C (32°F)	
Maximum Temperature	45°C (113°F) (max. heatplate temp.)	
Storage Temperature	-30°C to 85°C (-22°F to 185°F)	
Package Dissipation	Heatplate: 0 to 30W, depending on motor current; $P = (I_{AVG}/12 A)30 W$	
	Cover: 3 watts maximum	
Humidity	0 to 95% non condensing	
Contaminants	OEM670X/675X is not waterproof, oilproof, or dustproof.	
<b>MECHANICAL</b>		
Power Connector	10 pin screw terminal	
	14 AWG (2.5 mm <sup>2</sup> ) maximum wire size	
Input/Output Connector	25 Pin D-connector	
Size	5x1.6x3.5 in (127x41x89 mm) approx.	
Dimensions	see <i>Chapter ② Installation</i>	
Weight	12 ounces (0.35 kg)	

### ③ Specifications • OEM670X/675X

## Motor Specifications

### Motor Specifications: SM160

Parameter	Symbol	Units	SM160A	SM160B
Stall Torque Continuous <sup>1</sup>	$T_{cs}$	lb-in/oz-in	0.88/14.1	0.89/14.2
		N-m	0.10	0.10
Stall Current Continuous <sup>1</sup>	$I_{cs}$	amperes-rms	2.6	5.1
Rated Speed <sup>2</sup>	$\omega_r$	rpm	7500	7500
Peak Torque <sup>1,6</sup>	$T_{pk}$	lb-in/oz-in	2.65/42.4	2.67/42.7
		N-m	0.30	0.30
Peak Current, rms <sup>1</sup>	$I_{pk}$	amperes	7.8	15.2
Torque @ Rated Speed <sup>1</sup>	$T_c$	lb-in/oz-in	0.66/10.5	0.66/10.5
		N-m	0.075	0.075
Rated Power—Output Shaft <sup>1</sup>	$P_o$	watts	58	58
Voltage Constant <sup>3,4</sup>	$K_b$	volts/radian/sec	0.0384	0.0198
Voltage Constant <sup>3,4</sup>	$K_e$	volts/KRPM	4.02	2.08
Torque Constant <sup>3,4</sup>	$K_t$	oz-in/amp rms	5.43	2.81
		N-m/amp rms	0.038	0.020
Resistance <sup>1,3</sup>	R	ohms	3.43	0.9
Inductance <sup>5</sup>	L	millihenries	0.53	0.13
Thermal Resistance <sup>1</sup>	$R_{th}$	°C/watt	3.2	3.2
Motor Constant	Km	oz-in/ $\sqrt{watt}$	2.93	2.96
		N-m/ $\sqrt{watt}$	0.021	0.021
Viscous Damping	B	oz-in/Krpm	0.267	0.267
		N-m/Krpm	0.002	0.002
Torque/Static Friction	$T_f$	oz-in	1.0	1.0
		N-m	0.007	0.007
Thermal Time Constant	$\tau_{th}$	minutes	23	23
Electrical Time Constant	$\tau_e$	milliseconds	0.16	0.15
Mechanical Time Constant	$\tau_m$	milliseconds	0.73	0.72
Rotor Inertia	J	lb-in-sec <sup>2</sup>	0.0000443	0.0000443
		kg-m <sup>2</sup> x 10 <sup>-6</sup>	5.0	5.0
Weight	#	pounds	0.72	0.72
		kilograms	0.327	0.327
Winding Class			H	H

<sup>1</sup> @ 25°C ambient with 10 x 10 x 25 in. aluminum mounting plate, 90°C winding temperature. At 40°C ambient, derate phase currents and torques by 12%.

<sup>2</sup> With 500 ppr encoders. For 1,000 ppr encoders, derate to 6,000 rpm. For higher speed operation, please contact factory.

<sup>3</sup> ±10% line-to-line

<sup>4</sup> Peak value

<sup>5</sup> ±30%, line-to-line, inductance bridge measurement @ 1 kHz

<sup>6</sup> Peak current for 1 second with initial winding temperature of 60°C or less.  
All specifications are subject to engineering change.

## Motor Specifications: SM161 and SM162

Parameter	Symbol	Units	SM161A	SM161B	SM162A	SM162B
Stall Torque Continuous <sup>1</sup>	$T_{cs}$	lb-in/oz-in	1.5/24	1.5/24	2.75/44	2.75/44
		N-m	0.169	0.169	0.311	0.311
Stall Current Continuous <sup>1</sup>	$I_{cs}$	amperes-rms	2.1	4.1	2.1	4.0
Rated Speed <sup>2</sup>	$\omega_r$	rpm	7,500	7,500	7,500	7,500
Peak Torque <sup>1,6</sup>	$T_{pk}$	lb-in/oz-in	4.5/72	4.5/72	8.25/132	8.25/132
		N-m	0.509	0.509	0.933	0.933
Peak Current, rms <sup>1</sup>	$I_{pk}$	amperes	10.5	20.5	10.5	20.0
Torque @ Rated Speed <sup>1</sup>	$T_c$	lb-in/oz-in	1.25/20	1.25/20	2.56/41	2.56/41
		N-m	0.141	0.141	0.290	0.290
Rated Power—Output Shaft <sup>1</sup>	$P_o$	watts	110	110	222	227
Voltage Constant <sup>3,4</sup>	$K_b$	volts/radian/sec	0.079	0.041	0.147	0.078
Voltage Constant <sup>3,4</sup>	$K_e$	volts/KRPM	8.27	4.29	15.39	8.17
Torque Constant <sup>3,4</sup>	$K_t$	oz-in/amp rms	11.18	5.8	20.8	11.05
		N-m/amp rms	0.079	0.041	0.147	0.078
Resistance <sup>1,3</sup>	R	ohms	4.53	1.24	6.5	1.73
Inductance <sup>5</sup>	L	millihenries	0.808	0.21	1.39	0.334
Thermal Resistance <sup>1</sup>	$R_{th}$	°C/watt	2.75	2.67	2.0	2.01
Motor Constant	Km	oz-in/ $\sqrt{\text{watt}}$	5.36	5.26	8.66	8.36
		N-m/ $\sqrt{\text{watt}}$	0.038	0.037	0.061	0.059
Viscous Damping	B	oz-in/Krpm	0.257	0.171	0.234	0.276
		N-m/Krpm	0.002	0.001	0.002	0.002
Torque/Static Friction	$T_f$	oz-in	1.0	1.0	1.1	1.1
		N-m	0.007	0.007	0.007	0.007
Thermal Time Constant	$\tau_{th}$	minutes	30	30	30	3.0
Electrical Time Constant	$\tau_e$	milliseconds	0.178	0.169	0.21	0.193
Mechanical Time Constant	$\tau_m$	milliseconds	9.2	9.4	5	6.2
Rotor Inertia	J	lb-in-sec <sup>2</sup>	0.000094	0.000094	0.000163	0.000163
		kg-m <sup>2</sup> x 10 <sup>-6</sup>	10.6	10.6	18.4	18.4
Weight	#	pounds	1.1	1.1	1.6	1.6
		kilograms	0.50	0.50	0.73	0.73
Winding Class			H	H	H	H

<sup>1</sup> @ 25°C ambient with 10 x 10 x 25 in. aluminum mounting plate, 90°C winding temperature. At 40°C ambient, derate phase currents and torques by 12%.

<sup>2</sup> With 500 ppr encoders. For 1,000 ppr encoders, derate to 6,000 rpm. For higher speed operation, please contact factory.

<sup>3</sup> ±10% line-to-line

<sup>4</sup> Peak value

<sup>5</sup> ±30%, line-to-line, inductance bridge measurement @ 1 kHz

<sup>6</sup> Peak current for 1 second with initial winding temperature of 60°C or less.  
All specifications are subject to engineering change.

### ③ Specifications • OEM670X/675X

## Motor Specifications: SM230 and SM231

Parameter	Symbol	Units	SM230A	SM230B	SM231A	SM231B
Stall Torque Continuous <sup>1</sup>	$T_{cs}$	lb-in/oz-in	1.8/28.9	1.7/27.6	2.87/50	2.87/46
		N-m	0.204	0.195	0.353	0.353
Stall Current Continuous <sup>1</sup>	$I_{cs}$	amperes-rms	2.5	5.0	2.1	4.1
Rated Speed <sup>2</sup>	$\omega_r$	rpm	7500	7500	7,500	7,500
Peak Torque <sup>1,6</sup>	$T_{pk}$	lb-in/oz-in	5.4/87	5.2/83	8.61/150	8.61/150
		N-m	0.615	0.587	1.060	1.060
Peak Current, rms <sup>1</sup>	$I_{pk}$	amperes	7.5	15	10.5	20.5
Torque @ Rated Speed <sup>1</sup>	$T_c$	lb-in/oz-in	1.5/24	1.4/23	2.37/38	2.25/36
		N-m	0.170	0.163	0.269	0.254
Rated Power—Output Shaft <sup>1</sup>	$P_o$	watts	134	127	205	205
Voltage Constant <sup>3,4</sup>	$K_b$	volts/radian/sec	0.081	0.0391	0.169	0.079
Voltage Constant <sup>3,4</sup>	$K_e$	volts/KRPM	8.52	4.09	16.86	8.27
Torque Constant <sup>3,4</sup>	$K_t$	oz-in/amp rms	11.52	5.54	22.8	11.18
		N-m/amp rms	0.081	0.039	0.161	0.079
Resistance <sup>1,3</sup>	R	ohms	4.43	1.12	5.22	1.46
Inductance <sup>5</sup>	L	millihenries	1.19	0.28	1.64	0.44
Thermal Resistance <sup>1</sup>	$R_{th}$	°C/watt	2.67	2.67	2.23	1.86
Motor Constant	Km	oz-in/ $\sqrt{\text{watt}}$	5.47	5.24	9.97	9.68
		N-m/ $\sqrt{\text{watt}}$	0.039	0.037	0.070	0.068
Viscous Damping	B	oz-in/Krpm	0.375	0.375	0.565	0.266
		N-m/Krpm	0.003	0.003	0.004	0.002
Torque/Static Friction	$T_f$	oz-in	1.0	1.0	1.2	1.2
		N-m	0.007	0.007	0.008	0.008
Thermal Time Constant	$\tau_{th}$	minutes	30	30	30	30
Electrical Time Constant	$\tau_e$	milliseconds	0.27	0.25	0.31	0.3
Mechanical Time Constant	$\tau_m$	milliseconds	16.97	18.51	13.7	14.5
Rotor Inertia	J	lb-in-sec <sup>2</sup>	0.000224	0.000224	0.00046	0.00046
		kg-m <sup>2</sup> x 10 <sup>-6</sup>	25.3	25.3	52.0	52.0
Weight	#	pounds	1.2	1.2	2.6	2.6
		kilograms	0.54	0.54	1.18	1.18
Winding Class			H	H	H	H

<sup>1</sup> @ 25°C ambient with 10 x 10 x 25 in. aluminum mounting plate, 90°C winding temperature. At 40°C ambient, derate phase currents and torques by 12%.

<sup>2</sup> With 500 ppr encoders. For 1,000 ppr encoders, derate to 6,000 rpm. For higher speed operation, please contact factory.

<sup>3</sup> ±10% line-to-line

<sup>4</sup> Peak value

<sup>5</sup> ±30%, line-to-line, inductance bridge measurement @ 1 kHz

<sup>6</sup> Peak current for 1 second with initial winding temperature of 60°C or less.

All specifications are subject to engineering change.

## Motor Specifications: SM232 and SM233

Parameter	Symbol	Units	SM232A	SM232B	SM233A	SM233B
Stall Torque Continuous <sup>1</sup>	$T_{cs}$	lb-in/oz-in	5.75/92	6.12/98	8.75/144	8.75/140
		N-m	0.650	0.693	1.08	0.989
Stall Current Continuous <sup>1</sup>	$I_{cs}$	amperes-rms	2.1	4.1	2.1	4.1
Rated Speed	$\omega_r$	rpm	4,500	7,500 <sup>2</sup>	2,800	7,500 <sup>2</sup>
Peak Torque <sup>1,6</sup>	$T_{pk}$	lb-in/oz-in	17.25/276	18.36/294	26.25/432	26.25/432
		N-m	1.95	2.08	3.05	3.05
Peak Current, rms <sup>1</sup>	$I_{pk}$	amperes	10.5	20.5	10.5	20.5
Torque @ Rated Speed <sup>1</sup>	$T_c$	lb-in/oz-in	4.87/78	5.12/82	8.37/134	7.12/114
		N-m	0.551	0.580	0.947	0.806
Rated Power—Output Shaft <sup>1</sup>	$P_o$	watts	260	450	277	505
Voltage Constant <sup>3,4</sup>	$K_b$	volts/radian/sec	0.31	0.169	0.484	0.242
Voltage Constant <sup>3,4</sup>	$K_e$	volts/KRPM	32.45	17.69	50.6	25.33
Torque Constant <sup>3,4</sup>	$K_t$	oz-in/amp rms	43.89	23.91	68.53	34.23
		N-m/amp rms	0.310	0.169	0.484	0.242
Resistance <sup>1,3</sup>	R	ohms	7.5	2.01	9.65	2.58
Inductance <sup>5</sup>	L	millihenries	2.9	0.782	4.08	1.06
Thermal Resistance <sup>1</sup>	$R_{th}$	°C/watt	1.58	1.5	1.25	1.26
Motor Constant	Km	oz-in/ $\sqrt{watt}$	15.99	16.86	22.00	21.25
		N-m/ $\sqrt{watt}$	0.113	0.119	0.155	0.150
Viscous Damping	B	oz-in/Krpm	0.525	0.328	0.778	0.459
		N-m/Krpm	0.004	0.002	0.005	0.003
Torque/Static Friction	$T_f$	oz-in	2.0	2.0	2.25	2.25
		N-m	0.014	0.014	0.016	0.016
Thermal Time Constant	$\tau_{th}$	minutes	35	35	40	40
Electrical Time Constant	$\tau_e$	milliseconds	0.39	0.39	0.42	0.41
Mechanical Time Constant	$\tau_m$	milliseconds	8.6	8.8	5.4	7.0
Rotor Inertia	J	lb-in-sec <sup>2</sup>	0.00082	0.00082	0.00117	0.00117
		kg-m <sup>2</sup> x 10 <sup>-6</sup>	92.6	92.6	132.2	132.2
Weight	#	pounds	3.5	3.5	4.4	4.4
		kilograms	1.59	1.59	2.00	2.00
Winding Class			H	H	H	H

<sup>1</sup> @ 25°C ambient with 10 x 10 x 25 in. aluminum mounting plate, 90°C winding temperature. At 40°C ambient, derate phase currents and torques by 12%.

<sup>2</sup> With 500 ppr encoders. For 1,000 ppr encoders, derate to 6,000 rpm. For higher speed operation, please contact factory.

<sup>3</sup> ±10% line-to-line

<sup>4</sup> Peak value

<sup>5</sup> ±30%, line-to-line, inductance bridge measurement @ 1 kHz

<sup>6</sup> Peak current for 1 second with initial winding temperature of 60°C or less.  
All specifications are subject to engineering change.

③ **Specifications • OEM670X/675X**

**Motor Specifications: NeoMetric N0701 and N0702**

Parameter	Symbol	Units	N0701 or N0341		N0702 or N0342	
			D	F	E	F
Winding Selection						
Stall Torque Continuous <sup>1, 4</sup>	$T_{cs}$	lb-in	5.8		10.6	
		N-m	0.65		1.20	
Stall Current Continuous <sup>1, 2</sup>	$I_{cs}$	amperes-rms	2.92	4.56	3.36	4.67
Rated Speed <sup>7</sup>	$\omega_r$	rpm	4850	7500	3025	4380
Peak Torque <sup>1</sup>	$T_{pk}$	lb-in	17.3		32.0	
		N-m	1.96		3.62	
Peak Current, rms <sup>1, 6</sup>	$I_{pk}$	amperes	8.8	13.7	10.1	14.0
Torque @ Rated Speed <sup>1</sup>	$T_c$	lb-in	4.6	4.7	8.6	8.6
		N-m	0.52	0.53	0.97	0.97
Rated Power—Output Shaft <sup>1</sup>	$P_o$	watts	265	415	309	447
Voltage Constant <sup>3, 4</sup>	$K_v$	volts/radian/sec	0.221	0.14	0.353	0.253
Voltage Constant <sup>3, 4</sup>	$K_v$	volts/KRPM	23.11	14.67	36.97	26.52
Torque Constant <sup>3, 4</sup>	$K_t$	lb-in/amp rms	1.95	1.24	3.12	2.24
		N-m/amp rms	0.22	0.14	0.35	0.25
Resistance <sup>3</sup>	R	ohms	5.52	2.27	5.22	2.7
Inductance <sup>5</sup>	L	millihenries	12.98	5.23	15.86	8.16
Thermal Resistance <sup>1</sup>	$R_{\theta}$	°C/watt	1.44		1.15	
Motor Constant	$K_m$	lb-in/ $\sqrt{\text{watt}}$	0.83	0.82	1.37	1.36
		N-m/ $\sqrt{\text{watt}}$	0.09	0.09	0.15	0.15
Viscous Damping	B	lb-in/Krpm	0.0438		0.050	
		N-m/Krpm	0.0050		0.0056	
Torque-Static Friction	$T_f$	oz-in	1.4		2.1	
		N-m	0.010		0.015	
Thermal Time Constant	$\tau_{th}$	minutes	45		45	
Electrical Time Constant	$\tau_e$	milliseconds	2.35		3.03	
Mechanical Time Constant	$\tau_m$	milliseconds	1.3		0.77	
Rotor Inertia	J	lb-in-sec <sup>2</sup>	0.000106		0.000173	
		kg-m <sup>2</sup> x 10 <sup>-6</sup>	12.0		19.5	
Weight	#	pounds	3.54		4.53	
		kg	1.47		2.05	
Winding Class			H		H	

<sup>1</sup> @ 25°C ambient with 10 x 10 x 0.25 in. aluminum mounting plate, 90°C encoder temperature.

<sup>2</sup> RMS current, line-to-line, six state commutation

<sup>3</sup> ±10% line-to-line

<sup>4</sup> Peak value

<sup>5</sup> ±30%, line-to-line, inductance bridge measurement @ 1 kHz

<sup>6</sup> Peak current for 2 second maximum with initial winding temperature of 40°C

<sup>7</sup> For "E", encoder option, 1000 ppr, maximum velocity is 6000 RPM

All specifications are subject to engineering change.

## Speed/Torque Curves

### Speed/Torque Curves<sup>2,3</sup>: SM 160, SM161 and SM162

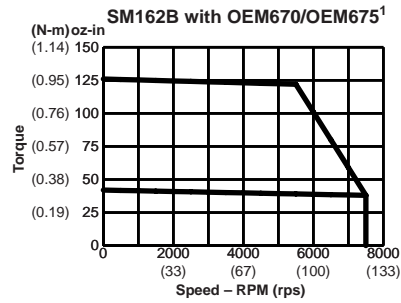
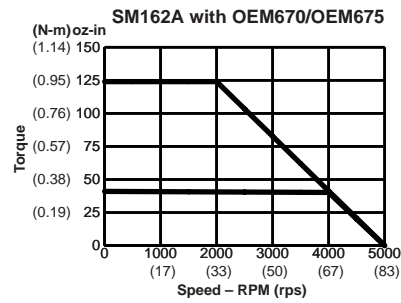
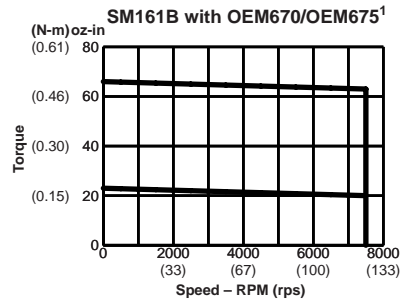
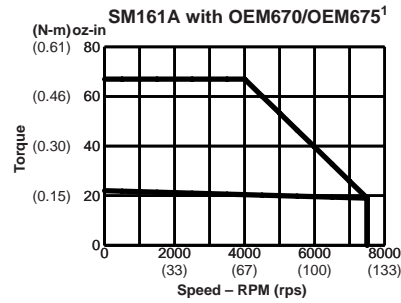
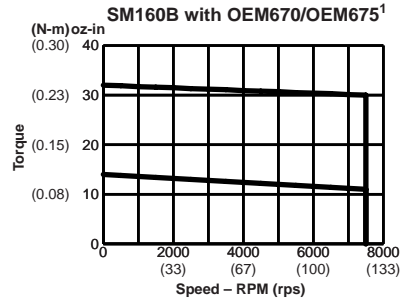
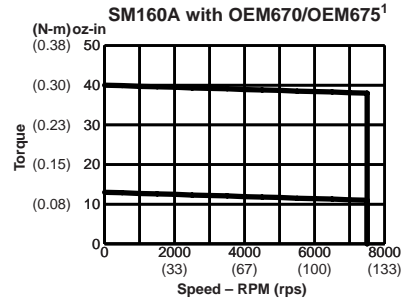

<sup>1</sup> For "E" encoder option (1000 ppr), maximum velocity is 6,000 rpm (100 rps).

<sup>2</sup> With 75VDC bus voltage; 25°C (77°F) ambient temperature.

<sup>3</sup> Although speed/torque curves are the same for the OEM670X and OEM675X, the OEM670X's current compensation loop is optimized for NeoMetric (slotted) motors; the OEM675X's current compensation loop is optimized for SM (slotless) motors. We strongly recommend that you use the OEM670X with NeoMetric motors, and use the OEM675X with SM motors. This provides the optimum system transient response.

③ Specifications • OEM670X/675X

**Speed/Torque Curves<sup>2,3</sup>: SM230, SM231, SM232, SM233**

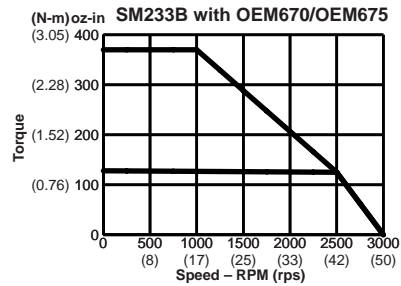
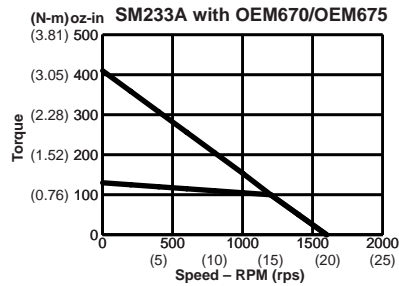
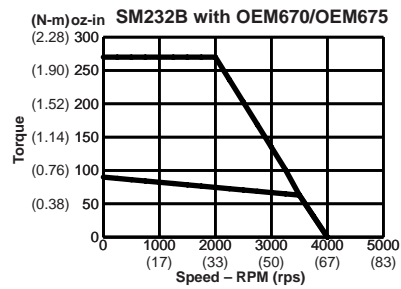
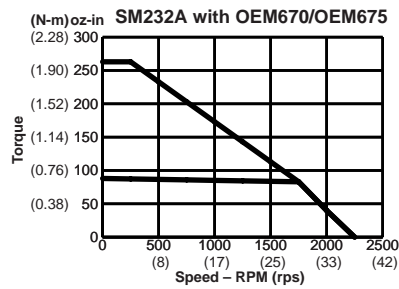
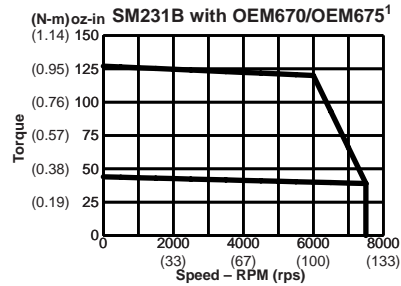
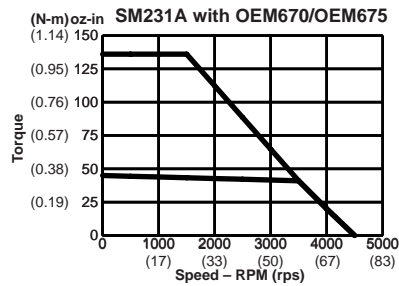
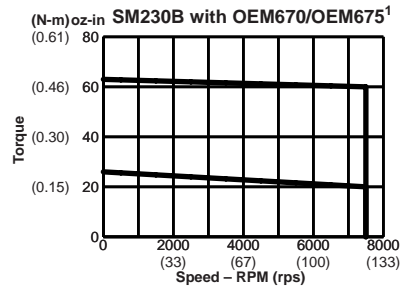
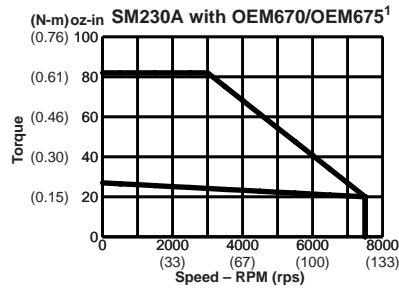

<sup>1</sup> For "E" encoder option (1000 ppr), maximum velocity is 6,000 rpm (100 rps).

<sup>2</sup> With 75VDC bus voltage; 25°C (77°F) ambient temperature.

<sup>3</sup> Although speed/torque curves are the same for the OEM670X and OEM675X, the OEM670X's current compensation loop is optimized for NeoMetric (slotted) motors; the OEM675X's current compensation loop is optimized for SM (slotless) motors. We strongly recommend that you use the OEM670X with NeoMetric motors, and use the OEM675X with SM motors. This provides the optimum system transient response.

## Speed/Torque Curves<sup>1,2</sup>: NeoMetric Motors

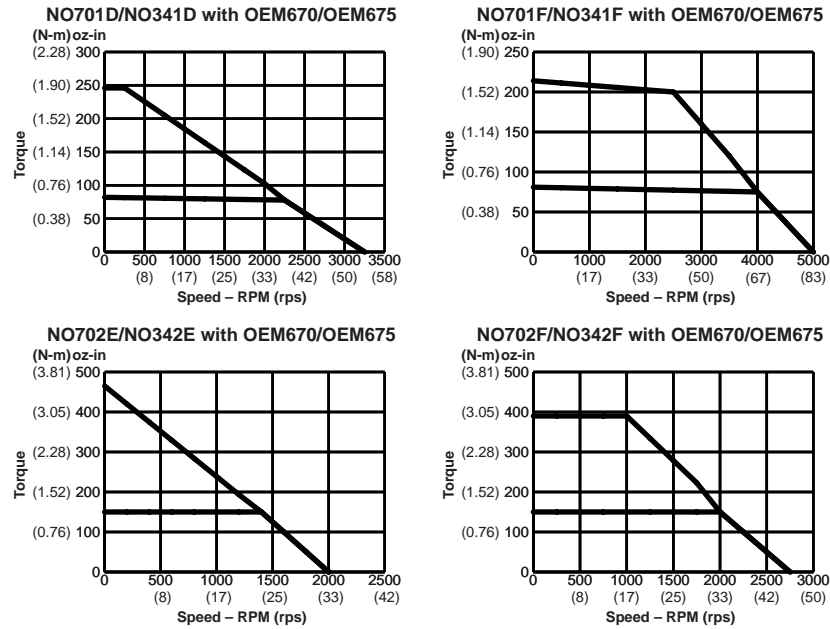

<sup>1</sup> With 75VDC bus voltage; 25°C (77°F) ambient temperature.  
<sup>2</sup> Although speed/torque curves are the same for the OEM670X and OEM675X, the OEM670X's current compensation loop is optimized for NeoMetric (slotted) motors; the OEM675X's current compensation loop is optimized for SM (slotless) motors. We strongly recommend that you use the OEM670X with NeoMetric motors, and use the OEM675X with SM motors. This provides the optimum system transient response.

## Motor Dimensions

### Motor Dimensions: Compumotor SM160 and SM230

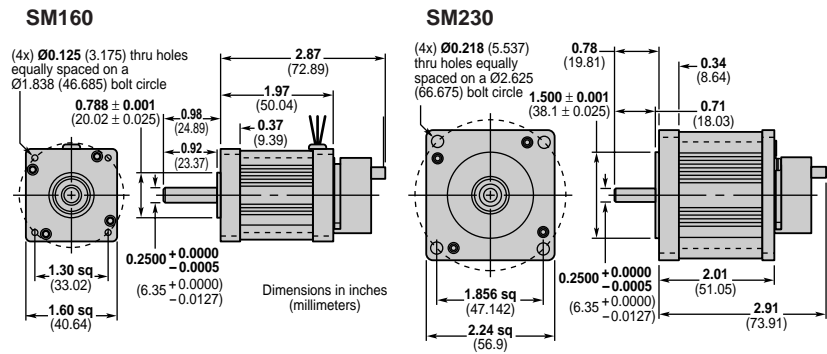

③ Specifications • OEM670X/675X

## Motor Dimensions: Compumotor SM Series, Size 16

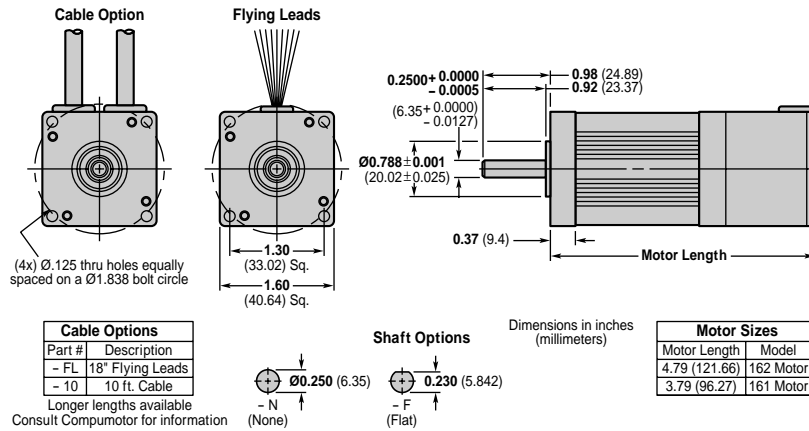

## Motor Dimensions: Compumotor SM Series, Size 23

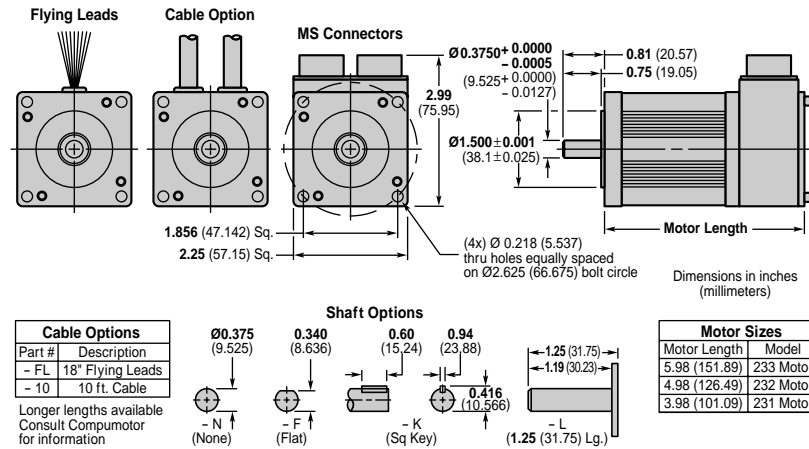

## Motor Dimensions: NeoMetric Series, Size 70

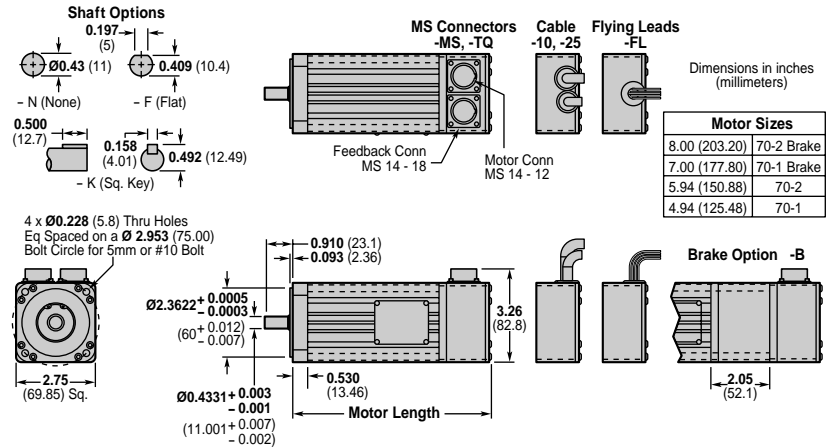

## Motor Dimensions: NeoMetric Series, Size 34

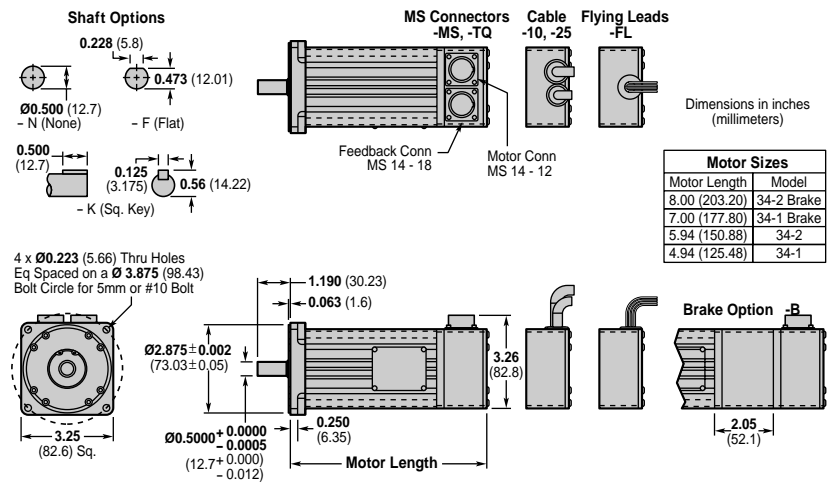

③ **Specifications • OEM670X/675X**

## **Encoder Specifications**

---

The same type of encoder is used on all SM and NeoMetric Series motors. Encoders have either 500 lines ("-D") or 1000 lines ("-E").

### **Mechanical**

Accuracy  $\pm 2$  min of arc

### **Electrical**

Input power 5 VDC  $\pm 5\%$ , 135 mA

Operating frequency 100 kHz max

Output device 26LS31

Sink/Source, nominal 20 mA

Suggested user interface 26LS32

## **Hall Effect Specifications**

---

Specifications for Hall effect outputs on SM and NeoMetric Series motors are listed below.

### **Electrical**

Input power 5 VDC  $\pm 5\%$ , 80 mA

Output device, open collector LM339

Maximum pull up 30 VDC

Sink 16 mA

## **COMMUTATION CHART**

---

Clockwise rotation as viewed from front shaft.

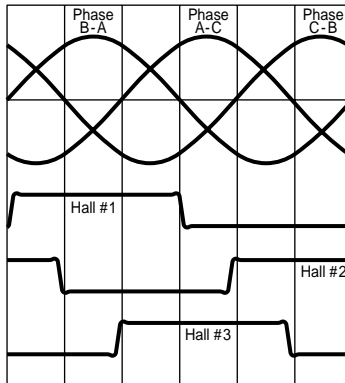

## Motor Wiring Information

---

### SM MOTORS – SIZE 16 AND SIZE 23

---

#### Motor Phase

Designation	-MS Option Pin No. MS14-12	-TQ Option Pin No. MS14-12	-H Option Pin No. MS14-12	-FL Option -10 Option -25 Option Wire Color
Phase A	J	J	J	Red/Yellow
Phase B	K	K	K	White/Yellow
Phase C	L	L	L	Black/Yellow
Ground	M	M	M	Green/Yellow
Shield	NC	NC	NC	—
Temp <sup>1</sup>	G	G	G	Yellow
Temp <sup>1</sup>	H	H	H	Yellow

#### Encoder

Designation	Pin No. MS14-18	Pin No. MS14-18	Not Applicable	Wire Color
Vcc	H	H	—	Red
Ground	G	G	—	Black
CH A+	A	A	—	White
CH A-	B	B	—	Yellow
CH B+	C	C	—	Green
CH B-	D	D	—	Blue
Index +	E	E	—	Orange
Index -	F	F	—	Brown
Shield	NC	NC	—	—

#### Hall-effect

Designation	Pin No. MS14-18	Pin No. MS14-12	Pin No. MS14-12	Wire Color
Hall GND	K	F	F	White/Green
Hall +5	M	B	B	White/Blue
Hall 1	T	C	C	White/Brown
Hall 2	U	D	D	White/Orange
Hall 3	P	E	E	White/Violet

Wiring color is provided for flying lead or cable versions.

③ **Specifications • OEM670X/675X**

**NEOMETRIC MOTORS – SIZE 070 (SIZE 034)**

**Motor Phase**

<b>Designation</b>	<b>Pin No. MS14-12</b>	<b>Wire Color</b>
Phase A	J	Red/Yellow
Phase B	K	White/Yellow
Phase C	L	Black/Yellow
Ground	M	Green/Yellow
Shield	NC	—
Continue for “H” or “TQ” Options		
Temp	G	Orange/Yellow
Temp	H	or Yellow (T)
Hall GND	F	White/Green
Hall +5	B	White/Blue
Hall 1	C	White/Brown
Hall 2	D	White/Orange
Hall 3	E	White/Violet

**Encoder/Commutation Connections**

<b>Designation</b>	<b>Pin No. MS14-18</b>	<b>Wire Color</b>
Encoder		
+5 VDC	H	Red
Ground	G	Black
CH A+	A	White
CH A-	B	Yellow
CH B+	C	Green
CH B-	D	Blue
Index +	E	Orange
Index -	F	Brown
Commutation		
Hall GND	K	White/Green
Hall +5	M	White/Blue
Hall 1	T	White/Brown
Hall 2	U	White/Orange
Hall 3	P	White/Violet
Temp	L	Orange/Yellow
Temp	N	or Yellow (T)
Brake Option		
Brake	R	Red/Blue
Brake	S	Red/Blue