



p/n YPM08119

ACR8000 Hardware Manual

Effective: October 7, 2002

This page intentionally left blank.

CHANGE NOTICE

ACR8000 Hardware Manual P/N PM08119 Version Change:

From: Version 1.02, Dated 7/8/1999

To: Version 1.03, Dated 12/7/2001

1. Page 32, Technical Specification Corrected operating temperature range and Digital I/O power requirements.

ACR8000 Hardware Manual P/N PM08119 Version Change:

From: Version 1.01, Dated 5/20/1998

To: Version 1.02, Dated 7/8/1999

2. Miscellaneous Added miscellaneous blank page comments.

ACR8000 Hardware Manual P/N PM08119 Version Change:

From: Version 1.00

To: Version 1.01, Dated 5/20/98

1. Page 31, ACR8000 Specification Change the DAC/Stepper Output stepper output frequency specification.
2. Page 39, ACR8000 Typical Connection Diagrams Corrected the Multiple Board RS-232 diagram on ACR8000 Wiring Diagram page 1.

Corrected the stepper output driver part number from "7407" to "7406" on ACR8000 Wiring Diagram page 2.

This page intentionally left blank.

CONTENTS

INTRODUCTION	1
CHAPTER 1	
HARDWARE INSTALLATION	3
Chapter Overview	5
Motherboard	6
Jumpers	6
Address Select	6
Serial Port Select	8
Interrupt Select.....	9
Encoder Pull-up Select.....	10
Connectors.....	12
Encoder Inputs.....	12
Analog Input / Output	14
Digital Input / Output	16
Communications	18
Isolated Power	20
Standalone Power.....	21
Daughterboard.....	22
Jumpers	22
EPROM Size Select	22
Factory Test	23
Battery Backup Select.....	24
Connectors.....	25
DSP Network.....	25
Factory Test	26
ACR1000 Master.....	27
CHAPTER 2	
ACR8000 EXPANSION I/O BOARD	
(OPTIONAL).....	29
CHAPTER 3	
ACR8000 SPECIFICATION	31
CHAPTER 4	
ACR8000 MECHANICAL DRAWINGS	35

TABLES

1.1 PC BUS status port bits	6
1.2 PC BUS port addresses	7
1.3 Serial port jumpers	8
1.4 PC BUS interrupt jumper	9
1.5 Encoder pull-up jumpers.....	11
1.6 Encoder input connectors.....	13
1.7 Analog I/O connector	15
1.8 Digital I/O connectors	17
1.9 Communications connector.....	19
1.10 Isolated power connector.....	20
1.11 Isolated power fuse.....	20
1.12 Standalone power connector	21
1.13 Standalone power fuses	21
1.14 EPROM size jumpers	22
1.15 Battery backup jumpers.....	24
1.16 DSP network connector	25
1.17 Factory test connector	26
1.18 ACR1000 master connector	27

FIGURES

1.1	Address select switch	6
1.2	Serial port jumpers	8
1.3	PC BUS interrupt jumper	9
1.4	Encoder pull-up jumpers.....	10
1.5	Encoder input connectors	12
1.6	Analog I/O connector	14
1.7	Digital I/O connectors	16
1.8	Communications connector.....	18
1.9	Isolated power connector	20
1.10	Standalone power connector	21
1.11	EPROM size jumpers	22
1.12	Factory test jumper	23
1.13	Battery backup jumpers.....	24
1.14	DSP network connector.....	25
1.15	Factory test connector	26
1.16	ACR1000 master connector	27
1.17	ACR8000 Motherboard Mechanical Dimensions.....	36
1.18	ACR8000 Daughterboard Mechanical Dimensions.....	37
1.19	ACR8000 Stacking Dimensions	38

This page intentionally left blank.

INTRODUCTION

This document provides hardware connection information for the Acroloop ACR8000 motion controller.

The ACR8000 is a floating point DSP-based 8 axis motion controller. It has onboard hardware to read up to eight incremental encoders and supply precision 16-bit analog for eight servo amplifiers. It is modular in nature and is offered in 2, 4, 6 or 8 axis configurations. This board will work in standalone mode as well as within a PC-AT bus chassis. In the PC-AT bus, the board takes one and one half slots.

This page intentionally left blank.

CHAPTER 1

Hardware Installation

This page intentionally left blank.

Chapter Overview

Description:

This chapter contains diagrams of the jumpers and connectors on the ACR8000 mother and daughter boards.

Before optically isolated digital inputs and outputs can be used, the card must be connected to an external 24 volt DC power supply. This connection is made at the PWR1 connector and is fused onboard at 3 amps to protect the controller card.

Encoder pull-up jumpers must be set correctly based on the types of encoders being used. Failure to set these jumpers correctly may cause damage to the encoders or to the receivers on the controller card.

There are no analog adjustment "pots" on the board. All analog gain and offset is under software control. The analog outputs must be wired to differential control signal inputs on a servo amplifier. The outputs provide an analog control voltage of ± 10 volts.

Stepper simm module outputs provide open-collector step and direction signals. There are no pull-up resistors provided on the Stepper outputs.

Factory default jumper settings for the Acr8000 mother and daughter boards are highlighted within the following jumper tables.

Motherboard Jumpers

Address Select (SW1)

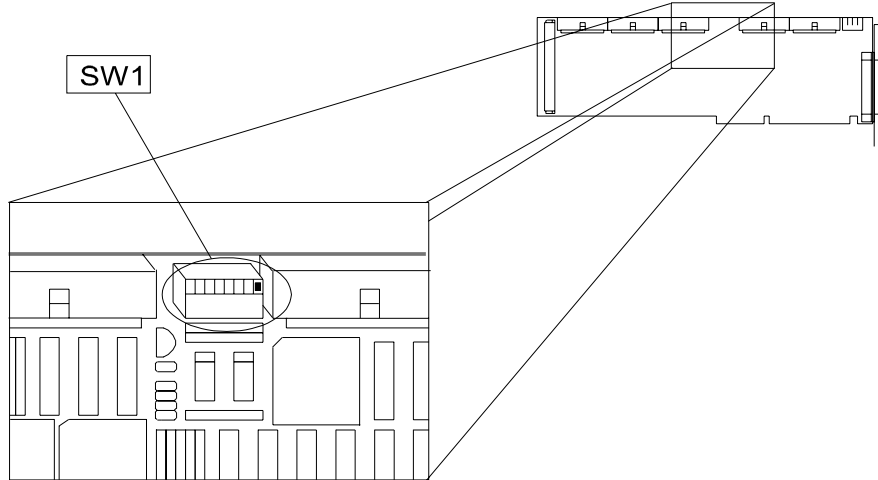

Figure 1.1 Address select switch

The ACR8000 can receive and transmit data through I/O ports on a PC BUS. The addresses of these ports are selectable using SW1 on the ACR8000 motherboard. The data port is used to both transmit and receive. Both the transmit and receive channels are connected to 512 byte First In / First Out (FIFO) hardware buffers.

The status port is used to see if data is waiting to be received from the card and if it is OK to send data to the card. The byte read from the status port is defined as follows:

BIT	Definition	Description
BIT7	Transmit Not Full	Clear to send one byte
BIT6	Transmit Not Half Full	Clear to send up to 255 bytes
BIT5	Receive Not Empty	Data available
BIT4	Transmit Not Empty	Still something in the buffer

Table 1.1 PC BUS status port bits

Motherboard Jumpers

Address Select (continued)

The following table shows how the switch positions relate to the ACR8000 card number and I/O port addresses. Note that switches SW1-1 through SW1-5 are reserved and should be left in the OFF position.

Card Number	SW1 Settings			Addresses	
	6	7	8	Data	Status
0	OFF	OFF	OFF	0x300	0x302
1	OFF	OFF	ON	0x304	0x306
2	OFF	ON	OFF	0x308	0x30A
3	OFF	ON	ON	0x30C	0x30E
4	ON	OFF	OFF	0x310	0x312
5	ON	OFF	ON	0x314	0x316
6	ON	ON	OFF	0x318	0x31A
7	ON	ON	ON	0x31C	0x31E

Table 1.2 PC BUS port addresses

Motherboard Jumpers

Serial Port Select (JS1, JS2)

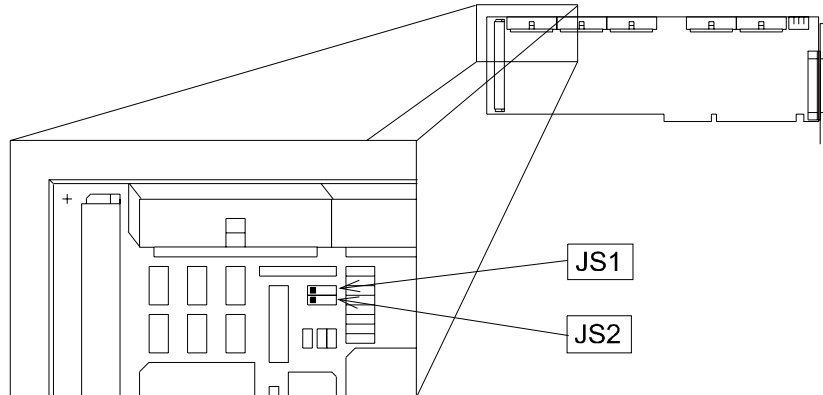

Figure 1.2 Serial port jumpers

COM1	COM2	JS1	JS2
RS232	RS232	1-2	1-2
RS232	RS422	1-2	2-3
RS422	RS232	2-3	1-2
RS422	RS422	2-3	2-3

Table 1.3 Serial port jumpers

In addition to the above jumper settings, the proper hardware option for RS-232 or RS-422 communications must be purchased and installed.

The serial communication ports have an automatic baud rate detection feature. Hitting ENTER key a few times from a dumb terminal or sending several CHR\$(13) characters from a serial host will wake up the communications port.

Motherboard Jumpers

Interrupt Select (JS3)

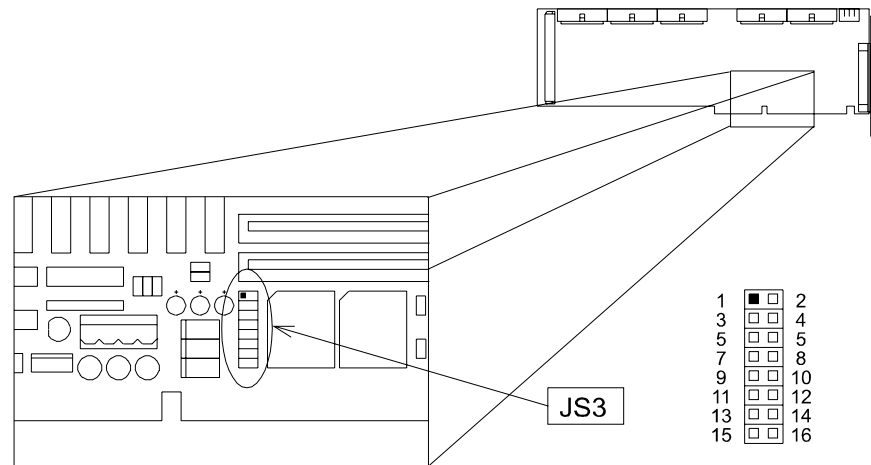

Figure 1.3 PC BUS interrupt jumper

The ACR8000 can be instructed to interrupt a PC host through the parallel bus by issuing a SET 112 command in immediate mode or from within a program. Interrupt driven software at the host level is an advanced topic and should only be attempted by someone with a thorough knowledge of interrupt driven code.

In order for the PC to see the interrupt, the proper jumper selection from the following table must be made. IRQ5 is usually a good choice since printer code seldom uses interrupts and use of the secondary printer port (LPT2) is even rarer.

Level	JS3	Common Function
Disabled	1-3	Not Applicable
IRQ3	1-2	Secondary Serial (COM2)
IRQ4	3-4	Primary Serial (COM1)
IRQ5	5-6	Secondary Parallel (LPT2)
IRQ7	7-8	Primary Parallel (LPT1)
IRQ10	9-10	Reserved (unused)
IRQ11	11-12	Reserved (unused)
IRQ12	13-14	Reserved (unused)
IRQ15	15-16	Reserved (unused)

Table 1.4 PC BUS interrupt jumper

IMPORTANT NOTE:

When the ACR8000 is used in a Pentium™ processor based PCI motherboard, the selected interrupt must be configured in the PCI motherboard BIOS as a Legacy ISA interrupt (or Used By ISA in some BIOS'), since the ACR8000 is an ISA board.

Motherboard Jumpers

Encoder Pull-up Select (JS21..JS28)

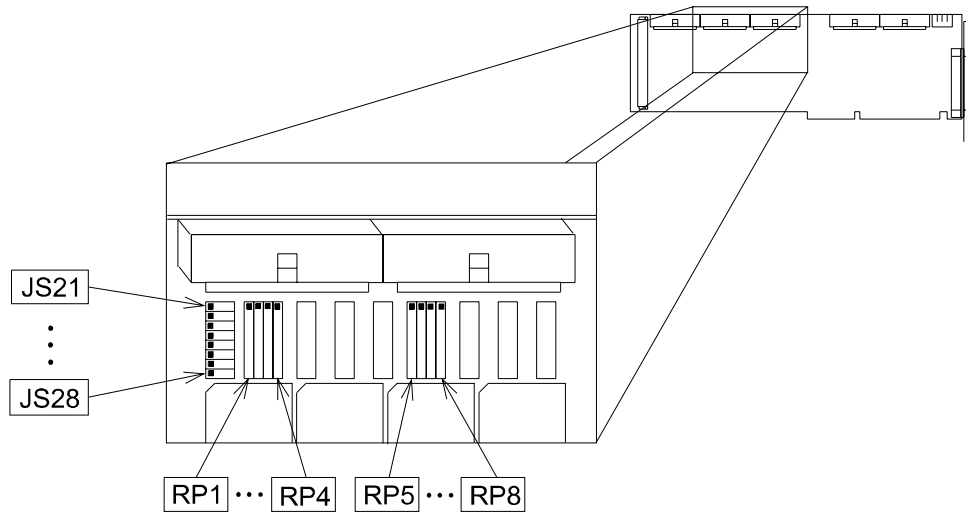

Figure 1.4 Encoder pull-up jumpers

The ACR8000 is capable of handling various types of incremental open-collector and line driver encoders. Care must be taken to setup each channel to match the encoder type as described below:

Open Collector Encoders:

When using open-collector encoders, the encoder channels must be pulled to either +5 or +12 volts, depending on the application. Pulling up to +12 volts provides higher noise immunity but causes a slower response time. For high frequency applications (encoder rates greater than one megahertz) the +5 volt pull-up selection may be necessary.

Motherboard Jumpers

Encoder Pull-up Select (continued)

Line Driver Encoders:

When using line driver (or balanced pair) encoders, the corresponding resistor pack should be removed from its socket. Leaving the resistor pack in can cause faulty encoder operation and possibly cause severe encoder damage. It does not matter what pull-up voltage is selected when the resistor pack is removed. Optionally, the resistor pack can be replaced with an 8-pin isolated resistor pack to supply termination resistance for the balanced signal pairs.

Pull-up selection:

The following table lists the pull-up jumper settings for each encoder:

ENC	Resistor	Jumper	+5V	+12V
0	RP1	JS21	1-2	*2-3
1	RP2	JS22	1-2	*2-3
2	RP3	JS23	1-2	*2-3
3	RP4	JS24	1-2	*2-3
4	RP5	JS25	1-2	*2-3
5	RP6	JS26	1-2	*2-3
6	RP7	JS27	1-2	*2-3
7	RP8	JS28	1-2	*2-3

 **WARNING**
Wiring a line driver encoder with the pull-up selected to +12 volts will permanently damage the encoder.

Table 1.5 Encoder pull-up jumpers

Motherboard Connectors

Encoder Inputs (P1A, P1B)

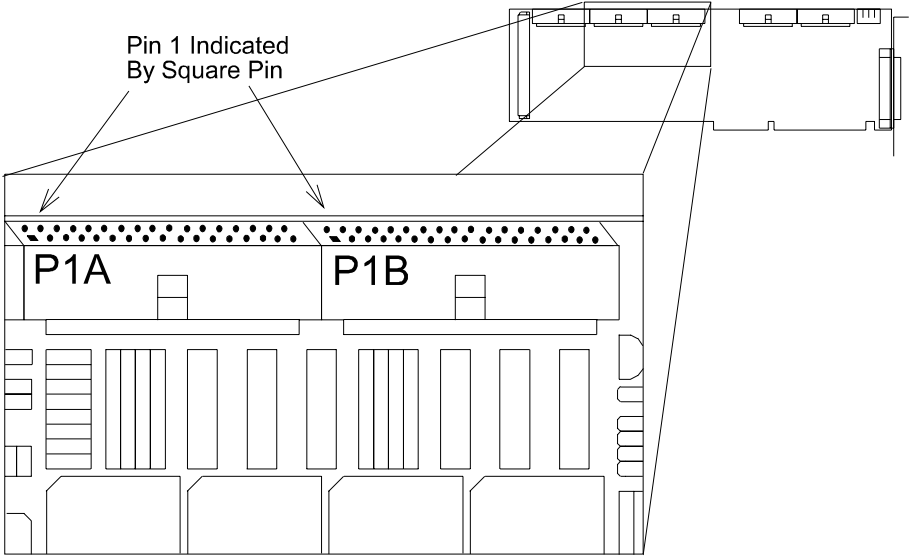

Figure 1.5 Encoder input connectors

Motherboard Connectors

Encoder Inputs (P1A, P1B), Cont'd

Note: P1A and P1B are 34-pin shrouded male headers.

P1A			
Usage	Pin	Pin	Usage
CHA0	1	2	CHA0'
CHB0	3	4	CHB0'
MRK0	5	6	MRK0'
VCC	7	8	GND
CHA1	9	10	CHA1'
CHB1	11	12	CHB1'
MRK1	13	14	MRK1'
VCC	15	16	GND
CHA2	17	18	CHA2'
CHB2	19	20	CHB2'
MRK2	21	22	MRK2'
VCC	23	24	GND
CHA3	25	26	CHA3'
CHB3	27	28	CHB3'
MRK3	29	30	MRK3'
VCC	31	32	GND
N.C.	33	34	N.C.

P1B			
Usage	Pin	Pin	Usage
CHA4	1	2	CHA4'
CHB4	3	4	CHB4'
MRK4	5	6	MRK4'
VCC	7	8	GND
CHA5	9	10	CHA5'
CHB5	11	12	CHB5'
MRK5	13	14	MRK5'
VCC	15	16	GND
CHA6	17	18	CHA6'
CHB6	19	20	CHB6'
MRK6	21	22	MRK6'
VCC	23	24	GND
CHA7	25	26	CHA7'
CHB7	27	28	CHB7'
MRK7	29	30	MRK7'
VCC	31	32	GND
N.C.	33	34	N.C.

Table 1.6 Encoder input connectors

Motherboard Connectors

Analog Input / Output (P2)

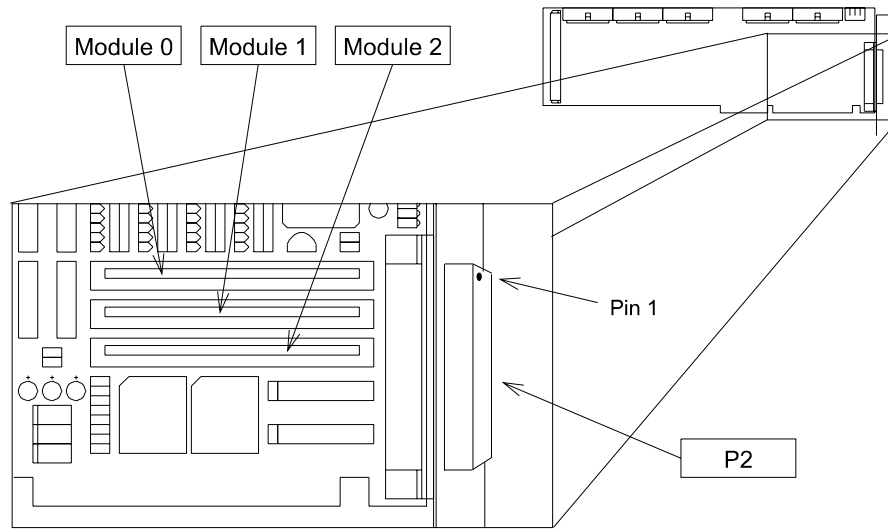

Figure 1.6 Analog I/O connector

Motherboard Connectors

Analog Input / Output (P2), Cont'd

Note: P2 is a standard 37-pin female D-plug.
Pin definitions in parentheses are for stepper modules.

P2				Module
Definition	Pin	Pin	Definition	
ASIG-0 (STEP-0)	1	20	AGND-0 (DIR-0)	Module 0
ASIG-1 (STEP-1)	2	21	AGND-1 (DIR-1)	
ASIG-2 (STEP-2)	3	22	AGND-2 (DIR-2)	Module 1
ASIG-3 (STEP-3)	4	23	AGND-3 (DIR-3)	
ASIG-4 (STEP-4)	5	24	AGND-4 (DIR-4)	
ASIG-5 (STEP-5)	6	25	AGND-5 (DIR-5)	Module 2
ASIG-6 (STEP-6)	7	26	AGND-6 (DIR-6)	
ASIG-7 (STEP-7)	8	27	AGND-7 (DIR-7)	Module0
AIN-0	9	28	AIN-1	
AIN-2	10	29	AIN-3	Module1
AIN-4	11	30	AIN-5	
AIN-6	12	31	AIN-7	None
(LCUR-0)	13	32	(LCUR-1)	
(LCUR-2)	14	33	(LCUR-3)	Module 2
(LCUR-4)	15	34	(LCUR-5)	
(LCUR-6)	16	35	(LCUR-7)	
WD-COM	17	36	WD-NO	
WD-COM	18	37	WD-NC	
AGND	19			

Table 1.7 Analog I/O connector

Motherboard Connectors

Digital Input / Output (P3 / P4)

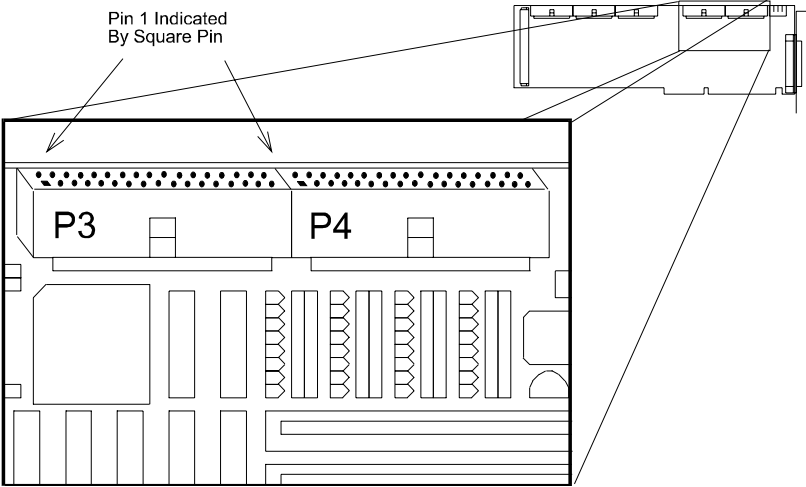

Figure 1.7 Digital I/O connectors

Motherboard Connectors

Digital Input / Output (P3 / P4), Cont'd

Note: P3 and P4 are 34-pin shrouded male headers.

P3			
Usage	Pin	Pin	Usage
OUT-32	1	2	OUT-33
OUT-34	3	4	OUT-35
OUT-36	5	6	OUT-37
OUT-38	7	8	OUT-39
OUT-40	9	10	OUT-41
OUT-42	11	12	OUT-43
OUT-44	13	14	OUT-45
OUT-46	15	16	OUT-47
OUT-48	17	18	OUT-49
OUT-50	19	20	OUT-51
OUT-52	21	22	OUT-53
OUT-54	23	24	OUT-55
OUT-56	25	26	OUT-57
OUT-58	27	28	OUT-59
OUT-60	29	30	OUT-61
OUT-62	31	32	OUT-63
VISO	33	34	VISO

P4			
Usage	Pin	Pin	Usage
INP-00	1	2	INP-01
INP-02	3	4	INP-03
INP-04	5	6	INP-05
INP-06	7	8	INP-07
INP-08	9	10	INP-09
INP-10	11	12	INP-11
INP-12	13	14	INP-13
INP-14	15	16	INP-15
INP-16	17	18	INP-17
INP-18	19	20	INP-19
INP-20	21	22	INP-21
INP-22	23	24	INP-23
INP-24	25	26	INP-25
INP-26	27	28	INP-27
INP-28	29	30	INP-29
INP-30	31	32	INP-31
GISO	33	34	GISO

Table 1.8 Digital I/O connectors

Motherboard Connectors

Communications (P5)

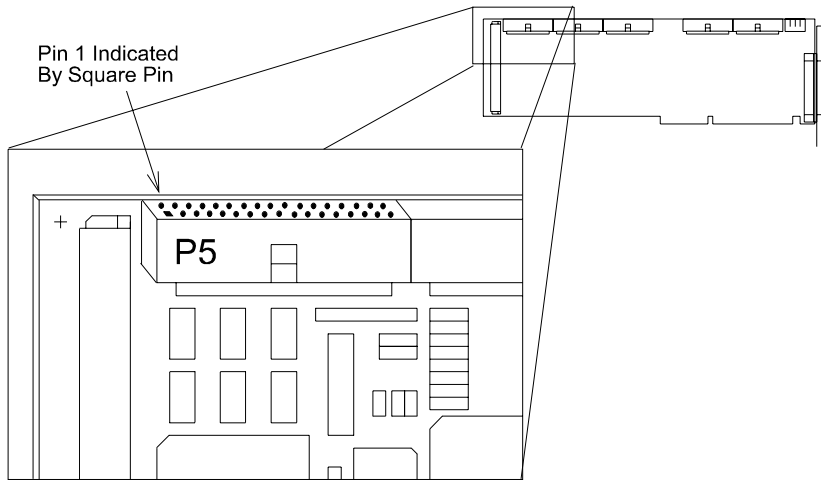

Figure 1.8 Communications connector

Motherboard Connectors

Communications (P5), Cont'd

Note: P5 is a 34-pin shrouded male header.

P5			
Usage	Pin	Pin	Usage
RXD1	1	2	TXD1
GND	3	4	MUX1
TXD1A	5	6	TXD1B
RXD1A	7	8	RXD1B
RXD2	9	10	TXD2
GND	11	12	MUX2
TXD2A	13	14	TXD2B
RXD2A	15	16	RXD2B
STB	17	18	AFD
ERR	19	20	INIT
SLIN	21	22	GND
PD0	23	24	PD1
PD2	25	26	PD3
PD4	27	28	PD5
PD6	29	30	PD7
ACK	31	32	BUSY
PE	33	34	SLCT

Table 1.9 Communications connectors

Motherboard Connectors

Isolated Power (PWR1)

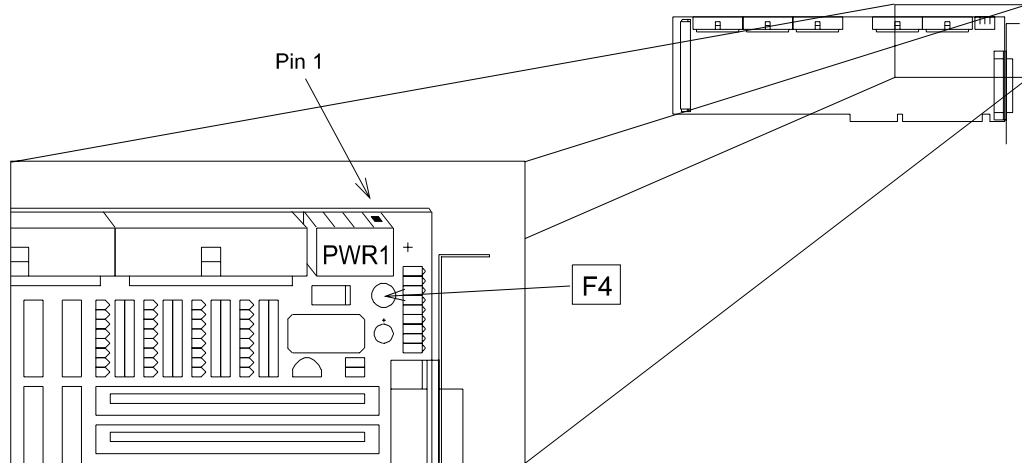

Figure 1.9 Isolated power connector

Note: PWR1 is a male 4-pin Weidmüller plug.

Pin	Description
1	External GND
2	External GND
3	External +24v
4	External +24v

Table 1.10 Isolated power connector

Fuse	Circuit	Amps	Microfuse Part #
F4	+24v	3	273.5

Table 1.11 Isolated power fuse

Motherboard Connectors

Standalone Power (PWR2)

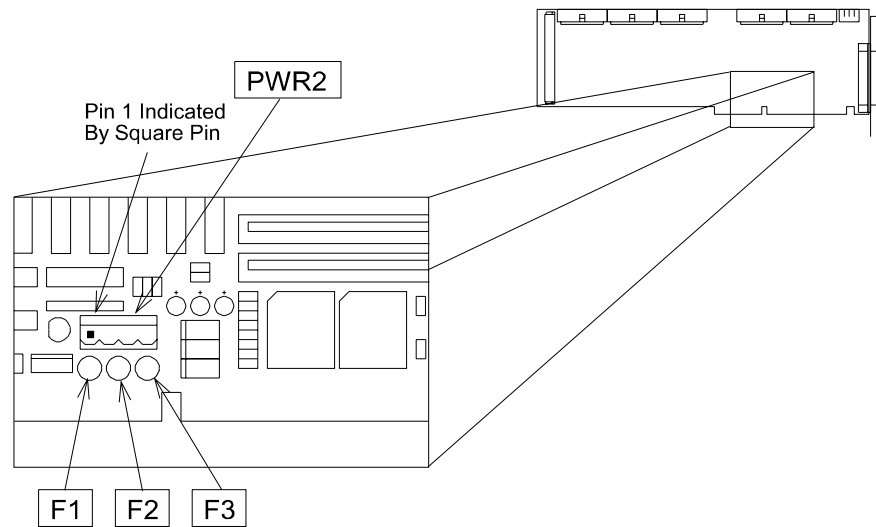

Figure 1.10 Standalone power connector

Note: PWR2 is a male 4-pin Weidmüller plug.

Pin	Description
1	Standalone GND
2	Standalone +5V
3	Standalone -12V
4	Standalone +12V

Table 1.12 Standalone power connector

Fuse	Circuit	Amps	Microfuse Part #
F1	+5v	4	273004
F2	-12v	1/8	273.125
F3	+12v	1/4	273.25

Table 1.13 Standalone power fuses

Daughterboard Jumpers

EPROM Size Select (JS1, JS2)

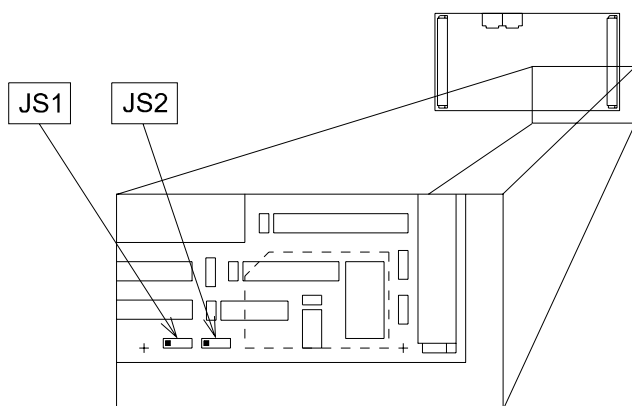

Figure 1.11 EPROM size jumpers

These jumpers are set at the factory to match the EPROM size required for the current firmware version. These jumpers should not be set by the user.

Memory	Atmel	JS1	JS2
64k x 32	27C1024	1-2	1-2
128k x 32	27C2048	1-2	1-2
256k x 32	27C4096	2-3	1-2
512k x 32	27C8192	2-3	2-3

Table 1.14 EPROM size jumpers

Daughterboard Jumpers

Factory Test (JS3)

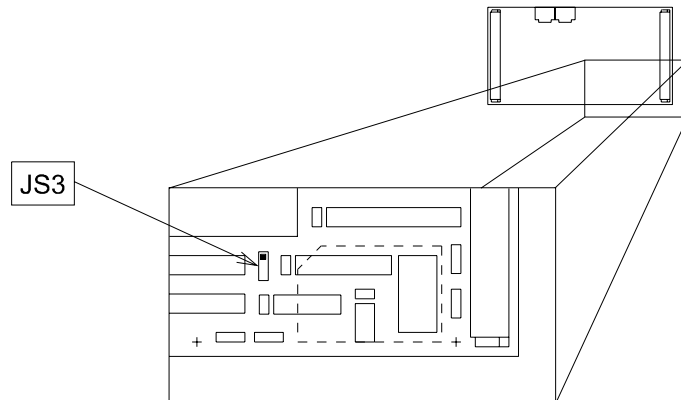

Figure 1.12 Factory test jumper

This jumper is for factory testing purposes only and should be left in the 1-2 position for normal operation.

Daughterboard Jumpers

Battery Backup Select (JS4, JS5)

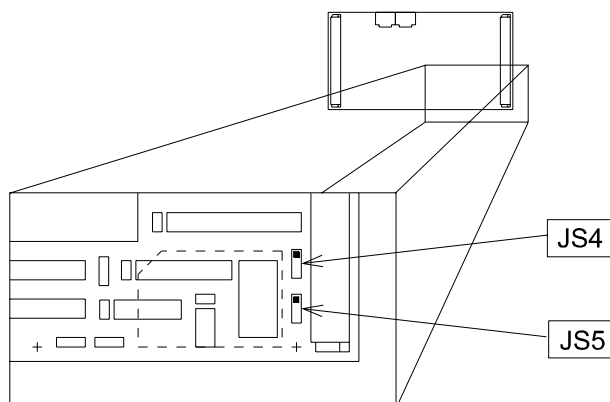

Figure 1.13 Battery backup jumpers

These two jumpers determine if the battery pack on the ACR8000 daughterboard is enabled or disabled. When enabled, user programs on the board are retained when power is removed.

Battery	JS4	JS5
Disabled	1-2	1-2
Enabled	2-3	2-3

Table 1.15 Battery backup jumpers

Daughterboard Connectors

DSP Network (P1)

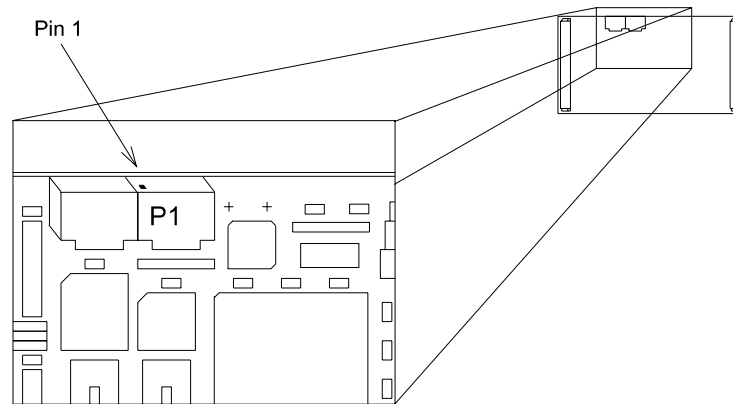

Figure 1.14 DSP network connector

Note: P1 is a 10-pin shrouded male header.

P1			
Usage	Pin	Pin	Usage
CLOCK	1	2	CLOCK'
DATA	3	4	DATA'
FRAME	5	6	FRAME'
N.C.	7	8	N.C.
SYNC	9	10	SYNC'

Table 1.16 DSP network connector

Daughterboard Connectors

Factory Test (P2)

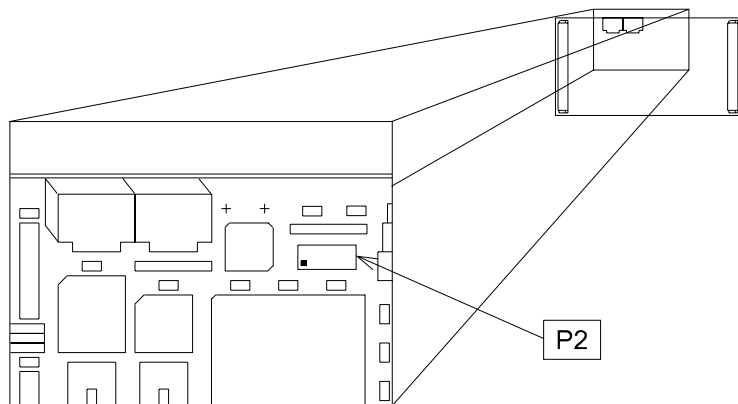

Figure 1.15 Factory test connector

Note: P2 is a 12-pin keyed male header.

P2			
Usage	Pin	Pin	Usage
EMU1	1	2	GND
EMU0	3	4	GND
EMU2	5	6	GND
VCC	7	8	KEY
EMU3	9	10	GND
H3	11	12	GND

Table 1.17 Factory test connector

Daughterboard Connectors

ACR1000 Master (P7)

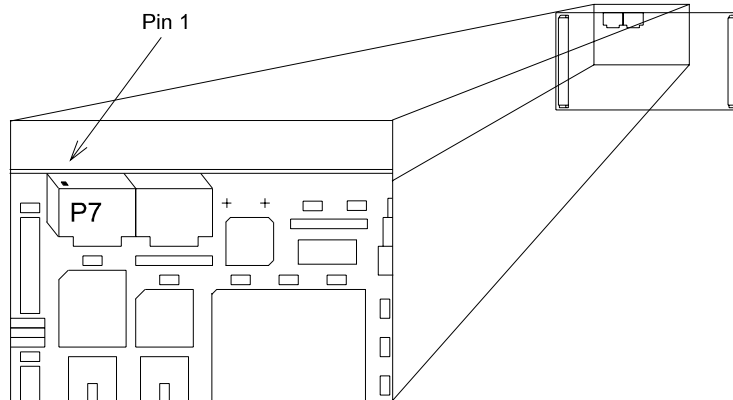

Figure 1.16 ACR1000 master connector

Note: P7 is a 10-pin shrouded male header.

P7			
Usage	Pin	Pin	Usage
GND	1	2	SLRDY
GND	3	4	MSTRT
GND	5	6	SLACK
SLINT	7	8	N.C.
GND	9	10	N.C.

Table 1.18 ACR1000 master connector

This page intentionally left blank.

CHAPTER 2

ACR8000 Expansion I/O Board

(Optional)

ACR8000 Expansion I/O Board (Optional)

The I/O for the ACR8000 expansion I/O cards is mapped into the previously reserved bits 256 through 511. There are also four new bits (Bits 116 thru 119, ACR2000/ACR8000 User's Guide, Miscellaneous Output Flags) which act as card enable control bits.

NOTE: The appropriate enable bit flag must be set before an expansion board's I/O will be updated.

The following is a list of jumpers and connectors for the I/O expansion cards:

J1	Address Select 0
J2	Address Select 1
J3	Watchdog Select
AP1	Input Connector (same pinout as Motherboard Digital Input Connector P4)
AP2	Output Connector (same pinout as Motherboard Digital Output Connector P3)
PWR1	External Power (same pinout as Motherboard Isolated Digital I/O Connector PWR1)

Table 1.19 I/O Expansion Board Jumper Settings

Card Number	0	1	2	3
	2-3	1-2	2-3	1-2
J2 Position	2-3	2-3	1-2	1-2
J3 Position	1-2	1-2	1-2	1-2
Card Enable	Bit 116	Bit 117	Bit 118	Bit 119
Input (Bits)	256 – 287	320 – 351	384 – 415	448 – 479
Output (Bits)	288 – 319	352 – 383	416 – 447	480 - 511

CHAPTER 3

ACR8000 SPECIFICATION

ACR8000 SPECIFICATION

ITEM	SPECIFICATION
CPU:	32 Bit Floating Point DSP @ 27 MHz
Processor Type:	Texas Instruments TMS320C30
Board Size:	1.5 Slots 13.25" x 4.25" PC Form Factor
Axis Configuration:	2, 4, 6, or 8 axes configurations
Weight:	1.5 lbs.
Operating Temperature:	0°C to 50°C (32°F to 122°F)
Humidity:	0 to 95%, Non-Condensing
Power Consumption:	+5 VDC @ 2.5A +12 VDC @ 0.13A -12 VDC @ 0.13A Note: Power consumption does not include any additional power required for external components (Encoders, Stepper Outputs, etc.).
External I/O Power Supply Requirements:	+24 VDC +3/-6VDC @ 4A
Encoder Inputs:	Up to 8 per card Differential Quadrature Encoder Open-Collector or Line Driver 0.1 Hz to 8 MHz Frequency Range 100mA maximum power source per channel
DAC/Stepper Outputs:	Up to 8 per card DAC Outputs: +/- 10VDC @ 5mA, maximum Programmable Output (DAC GAIN, DAC OFFSET) 16 Bit Resolution Single Ended input amplifiers can be used if caution is used to avoid ground loops. Stepper Outputs: Open-Collector Step, Direction, and Low Current Outputs (no pull-up resistors on-board); Step Output Frequency : 0 to 6KHz, pulse width 167us 6KHz to 4MHz, approx. 50% duty cycle

ACR8000 SPECIFICATION

ITEM	SPECIFICATION
Feedback Types:	Any Differential 5VDC or 12VDC including: <ul style="list-style-type: none">- Quadrature Encoder- Glass Scales- Analog (Optional)
Watchdog Relay:	+24VDC @ 1.0 A Single Pole - Double Throw (SPDT) Hardwire through P2 analog header
Digital Outputs:	+24VDC 50 mA x 32 = 1.6A full load, maximum 125mA (up to 13 outputs) maximum load 32 Optically Isolated (standard) Open Collector Sinking Type
Digital Inputs:	+24VDC Activates on 10mA per input 32 Optically Isolated (standard) Sinking Type
A/D Inputs:	Up to 8 single-ended or up to 4 differential 12 bit resolution Configurable for various analog inputs 9 microsecond conversion time
Communications:	PC-Bus, COM1, COM2, and LPT Simultaneous communications on all 4 ports
Serial Communications:	2 ports standard (COM1, COM2) Software Configurable RS-232 or RS-422 Automatic Baud Detect (300 Hz - 38.4 KHz)

This page intentionally left blank.

CHAPTER 4

ACR8000 MECHANICAL DRAWINGS

ACR8000 Motherboard Mechanical Dimensions

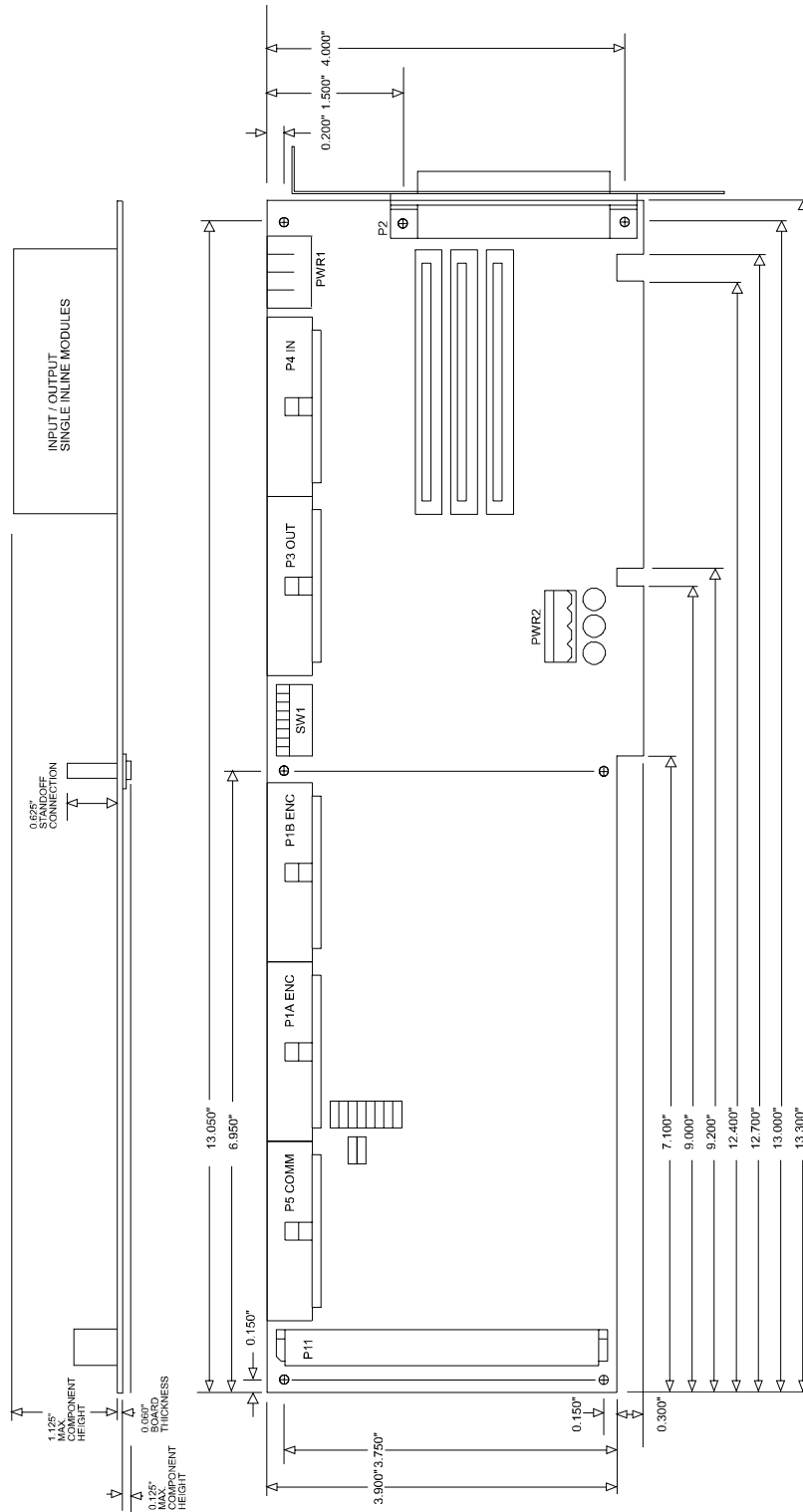

Figure 1.17 ACR8000 Motherboard Mechanical Dimensions

ACR8000 Daughterboard Mechanical Dimensions

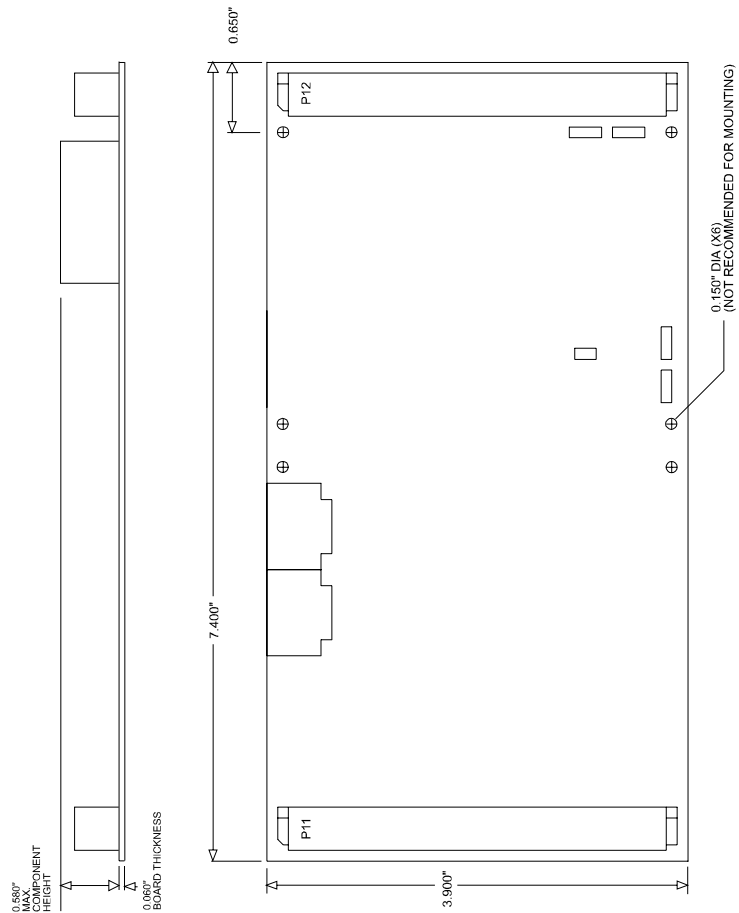

Figure 1.18 ACR8000 Daughterboard Mechanical Dimensions

ACR8000 Stacking Mechanical Dimensions

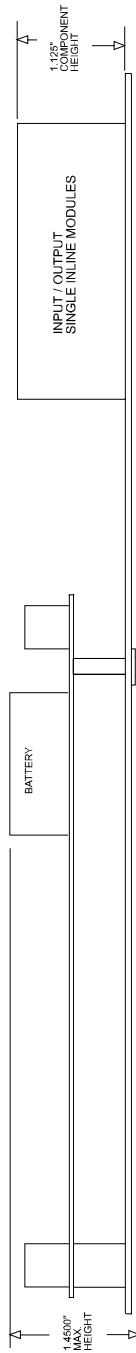

Figure 1.19 ACR8000 Stacking Dimensions

ACR8000 Typical Connection Diagrams

The following schematic sheets represent some typical connection and wiring diagrams for the ACR8000 board:

For electronic media, refer to the typical connection drawing file, ACR8000 TYPICAL CONNECTIONS.PDF, supplied separately on the AMCS CD P/N CD2000 under the \DOCS directory.