

APEX10/20/40 & APEX6151, 6152, & 6154 USER GUIDE ADDENDUM

This addendum is valid for APEX10 and APEX6151 units with serial numbers greater than: 97052700070.

It is also valid for APEX20/40 and APEX6152/6154 units with serial numbers greater than: 97073000109.

Information contained in this addendum covers recent changes not included in the most current User Guides for

- APEX10 APEX20 APEX40 Analog Servo Drive (user guide: 88-013904-02 A)
- APEX615n Servo Controller/Drive (user guide: 88-016148-01 A)

Topics covered in this addendum are:

APEX10, APEX6151 DIP Switch Changes:

DIP switch functions have been changed for:

Current Loop Compensation

Motor Thermal Time Constant

APEX20/40, APEX6152/6154 DIP Switch Changes:

DIP switch functions have been changed for:

Current Loop Compensation

New Motor Information:

Eight new Compumotor 70mm NeoMetric Series motors have been released with another eight 92mm motors pending release, all of which are for use with the APEX10/20/40 and APEX 6151/6152/6154. This addendum contains the following information for these motors:

DIP Switch Settings

Speed/Torque Curves

Motor Specifications

Motor Dimensions



Automation

Compumotor Division

88-016237-01 D 12/98

APEX40 Dip Switch Changes

New DIP switch functions are shown below for the APEX6152 Controller/Drive. DIP switch settings incorporating these changes for Compumotor's APEX Series, SM Series, and NeoMetric Series motors are shown on the following pages.

**APEX40
DIPs**

OFF ↑

SW 1

SW 2

SW 3

REGEN FAULT		1					
Enable	OFF						
Disable	ON						
HALL DEGREES		2					
120° Hall motor	OFF						
60° Hall motor	ON						
RESERVED		3					
Off	OFF						
POLE PAIR NUMBER		4		5			
2	OFF	OFF	OFF				
3	OFF	OFF	ON				
Reserved	ON	OFF	OFF				
Reserved	ON	ON	ON				
RESOLVER SPEED		6					
1	OFF						
2	ON						
CURRENT LOOP COMPENSATION		7		8			
NEW → 20 – 50 mH	OFF	OFF	OFF				
NEW → 4 – 10 mH	OFF	ON	ON				
NEW → 10 – 20 mH	ON	OFF	OFF				
Reserved	ON	ON	ON				
CONTINUOUS CURRENT (peak of sine wave)		1		2		3	
5.0 amps	OFF	OFF	OFF				
7.0	OFF	OFF	ON				
9.0	OFF	ON	OFF				
11.0	OFF	ON	ON				
13.0	ON	OFF	OFF				
15.0	ON	OFF	ON				
17.0	ON	ON	OFF				
PEAK CURRENT		4		5		6	
15.0 amps	OFF	OFF	OFF				
18.0	OFF	OFF	ON				
22.0	OFF	ON	OFF				
25.0	OFF	ON	ON				
29.0	ON	OFF	OFF				
32.0	ON	OFF	ON				
36.0	ON	ON	OFF				
40.0	ON	ON	ON				
MOTOR THERMAL TIME CONSTANT		7		8			
10 minutes	OFF	OFF	OFF				
20	OFF	ON	ON				
30	ON	OFF	OFF				
40	ON	ON	ON				
VELOCITY INTEGRATOR		1					
No	OFF						
Yes	ON						
ALIGNMENT MODE		2					
No	OFF						
Yes	ON						
COMMUTATION TEST MODE		3					
No	OFF						
Yes	ON						
HALL SELECT		4					
Resolver Mode	OFF						
Hall Mode	ON						
TACH SCALING		5					
One speed resolver (1V = 1,000 RPM with a one speed resolver)	OFF						
Two speed resolver (1V = 1,000 RPM with a two speed resolver)	ON						
COMMAND INPUT SCALING		6		7			
10V = 40.0 amps	OFF	OFF	OFF				
10V = 32.0 amps	OFF	ON	ON				
10V = 24.0 amps	ON	OFF	OFF				
10V = 22.0 amps	ON	ON	ON				
COLLECTIVE GAIN		8					
Off	OFF						
On	ON						

APEX6151 Dip Switch Changes

New DIP switch functions are shown below for the APEX6154 Controller/Drive. DIP switch settings incorporating these changes for Compumotor's APEX Series, SM Series, and NeoMetric Series motors are shown on the following pages.

**APEX6151
DIPs**

OFF ↑

		1	SW 1						8		
		1	2	3	4	5	6	7	8		
				SW 2							
		1	2	3	4	5	6	7	8		
				SW 3							
		1	2	3	4	5	6	7	8		
				SW 1							
		1	2	3	4	5	6	7	8		
				SW 2							
		1	2	3	4	5	6	7	8		
				SW 3							
		1	2	3	4	5	6	7	8		
				SW 1							
		1	2	3	4	5	6	7	8		
				SW 2							
		1	2	3	4	5	6	7	8		
				SW 3							
		1	2	3	4	5	6	7	8		
				SW 1							
		1	2	3	4	5	6	7	8		
				SW 2							
		1	2	3	4	5	6	7	8		
				SW 3							
		1	2	3	4	5	6	7	8		
				SW 1							
		1	2	3	4	5	6	7	8		
				SW 2							
		1	2	3	4	5	6	7	8		
				SW 3							
		1	2	3	4	5	6	7	8		
				SW 1							
		1	2	3	4	5	6	7	8		
				SW 2							
		1	2	3	4	5	6	7	8		
				SW 3							
		1	2	3	4	5	6	7	8		
				SW 1							
		1	2	3	4	5	6	7	8		
				SW 2							
		1	2	3	4	5	6	7	8		
				SW 3							
		1	2	3	4	5	6	7	8		
				SW 1							
		1	2	3	4	5	6	7	8		
				SW 2							
		1	2	3	4	5	6	7	8		
				SW 3							
		1	2	3	4	5	6	7	8		
				SW 1							
		1	2	3	4	5	6	7	8		
				SW 2							
		1	2	3	4	5	6	7	8		
				SW 3							
		1	2	3	4	5	6	7	8		
				SW 1							
		1	2	3	4	5	6	7	8		
				SW 2							
		1	2	3	4	5	6	7	8		
				SW 3							
		1	2	3	4	5	6	7	8		
				SW 1							
		1	2	3	4	5	6	7	8		
				SW 2							
		1	2	3	4	5	6	7	8		
				SW 3							
		1	2	3	4	5	6	7	8		
				SW 1							
		1	2	3	4	5	6	7	8		
				SW 2							
		1	2	3	4	5	6	7	8		
				SW 3							
		1	2	3	4	5	6	7	8		
				SW 1							
		1	2	3	4	5	6	7	8		
				SW 2							
		1	2	3	4	5	6	7	8		
				SW 3							
		1	2	3	4	5	6	7	8		
				SW 1							
		1	2	3	4	5	6	7	8		
				SW 2							
		1	2	3	4	5	6	7	8		
				SW 3							
		1	2	3	4	5	6	7	8		
				SW 1							
		1	2	3	4	5	6	7	8		
				SW 2							
		1	2	3	4	5	6	7	8		
				SW 3							
		1	2	3	4	5	6	7	8		
				SW 1							
		1	2	3	4	5	6	7	8		
				SW 2							
		1	2	3	4	5	6	7	8		
				SW 3							
		1	2	3	4	5	6	7	8		
				SW 1							
		1	2	3	4	5	6	7	8		
				SW 2							
		1	2	3	4	5	6	7	8		
				SW 3							
		1	2	3	4	5	6	7	8		
				SW 1							
		1	2	3	4	5	6	7	8		
				SW 2							
		1	2	3	4	5	6	7	8		
				SW 3							
		1	2	3	4	5	6	7	8		
				SW 1							
		1	2	3	4	5	6	7	8		
				SW 2							
		1	2	3	4	5	6	7	8		
				SW 3							
		1	2	3	4	5	6	7	8		
				SW 1							
		1	2	3	4	5	6	7	8		
				SW 2							
		1	2	3	4	5	6	7	8		
				SW 3							
		1	2	3	4	5	6	7	8		
				SW 1							
		1	2	3	4	5	6	7	8		
				SW 2							
		1	2	3	4	5	6	7	8		
				SW 3							
		1	2	3	4	5	6	7	8		
				SW 1							
		1	2	3	4	5	6	7	8		
				SW 2							
		1	2	3	4	5	6	7	8		
				SW 3							
		1	2	3	4	5	6	7	8		
				SW 1							
		1</									

APEX10 and 6151 Dip Switch Settings

New DIP switch functions are shown below for the APEX6151 Controller/Drive. DIP switch settings incorporating these changes for Compumotor's APEX Series, SM Series, and NeoMetric Series motors are shown on the following pages.

APEX10 & APEX6151 DIP SWITCH SETTINGS

OFF ↑

Initial Values for Tuning

<p>SM231AR</p>	<p>SM232AR</p>	<p>SM233BR</p>
<p>SM231AR</p>	<p>SM232AR</p>	<p>SM233BR</p>
<p>602</p>	<p>603</p>	
<p>N0701D</p>	<p>N0701F</p>	
<p>N0702E</p>	<p>N0702F</p>	
<p>N0703F</p>	<p>N0703G</p>	
<p>N0704F</p>	<p>N0704G</p>	
<p>N0921F</p>	<p>N0921G</p>	
<p>N0922G</p>		

APEX20 and 6152 Dip Switch Settings

New DIP switch functions are shown below for the APEX20 and 6152 Controller/ Drive. DIP switch settings incorporating these changes for Compumotor's APEX Series, SM Series, and NeoMetric Series motors are shown on the following pages.

APEX20 & APEX6152 DIP SWITCH SETTINGS

OFF ↑

Use these settings for your final configuration

<p>OFF ↑</p> <p>N0703G</p>		
<p>OFF ↑</p> <p>N0704G</p>	<p>OFF ↑</p> <p>N0921G</p>	<p>OFF ↑</p> <p>N0922G</p>
<p>OFF ↑</p> <p>N0923H</p>	<p>OFF ↑</p> <p>N0924J</p>	<p>OFF ↑</p> <p>N0922J</p>
<p>OFF ↑</p> <p>604</p>	<p>OFF ↑</p> <p>605</p>	<p>OFF ↑</p> <p>606</p>
<p>OFF ↑</p> <p>615</p>	<p>OFF ↑</p> <p>615</p>	<p>OFF ↑</p> <p>615</p>

APEX40 and 6154 Dip Switch Settings

New DIP switch functions are shown below for the APEX40 and 6154 Controller/Drive. DIP switch settings incorporating these changes for Compumotor's APEX Series, SM Series, and NeoMetric Series motors are shown on the following pages.

APEX40 & APEX6154 DIP SWITCH SETTINGS

OFF ↑

Use these settings for your final configuration

<p>N0922J</p>	<p>610</p>
<p>N0923H</p>	<p>620</p>
<p>N0923K</p>	<p>630</p>
<p>N0924J</p>	<p>635</p>
<p>N0924K</p>	<p>640</p>

Speed/Torque Curves – Compumotor SM and N Series Motors

The following speed/torque curves represent the available shaft torque at different operating speeds, under the following conditions. The performance of APEX 10 = APEX6151; APEX20 = APEX6152; and APEX40 = APEX6154.

- 25°C (77°F) ambient temperature
- Nominal torque constant K_t
- Motor mounted to heatsink: 10" x 10" x 0.25" aluminum

Actual motor torque may vary $\pm 10\%$ due to motor manufacturing variances. All SM motor speed/torque data obtained with APEX10 or APEX6151 at 120VAC. All NeoMetric motor speed/torque data obtained with indicated drive at 240VAC.

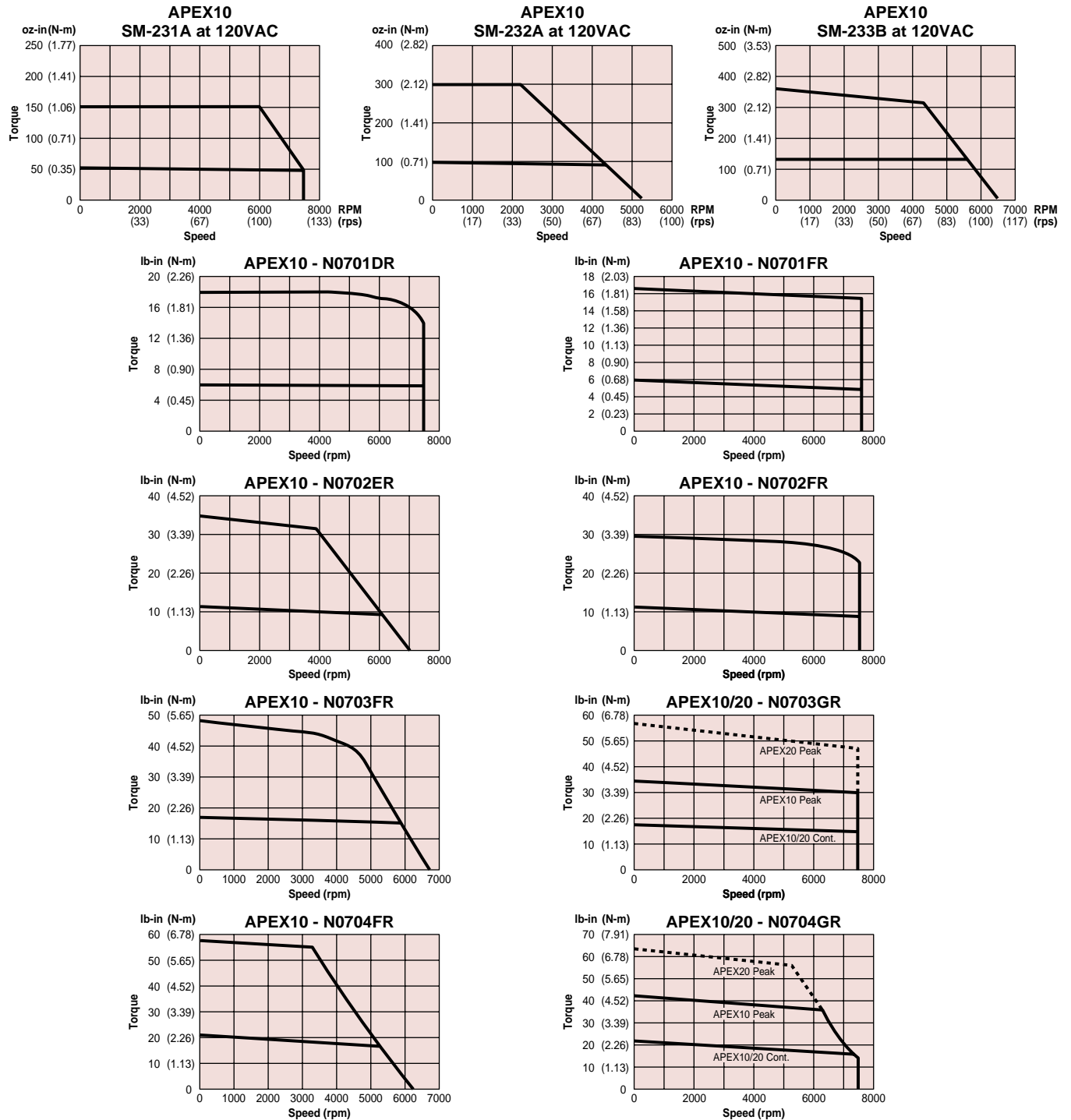

Speed/Torque Curves – Compumotor NeoMetric Series Motors

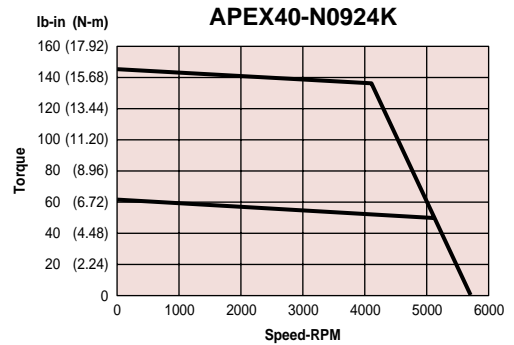
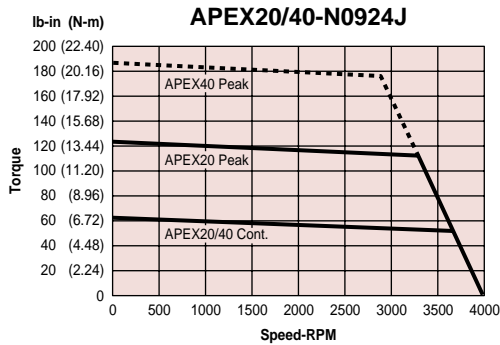
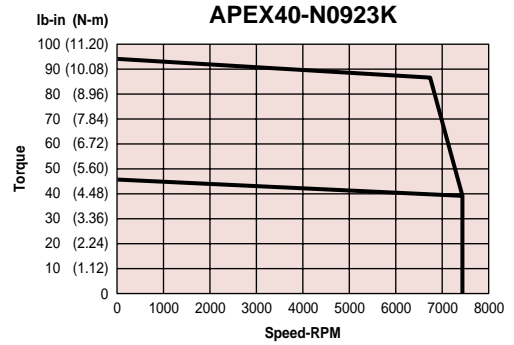
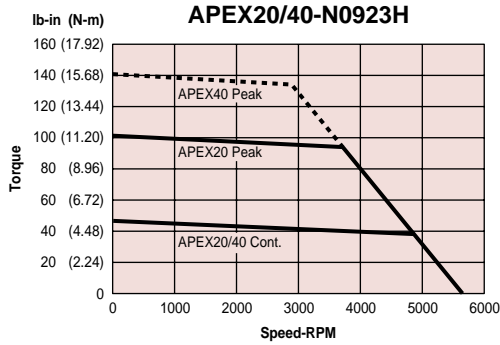
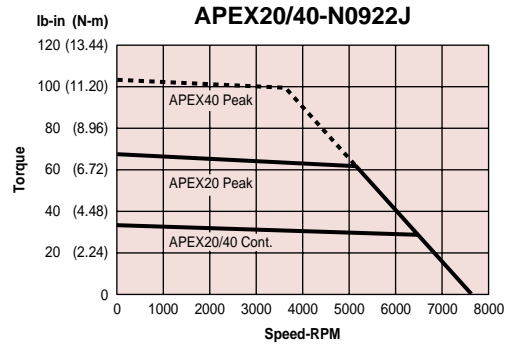
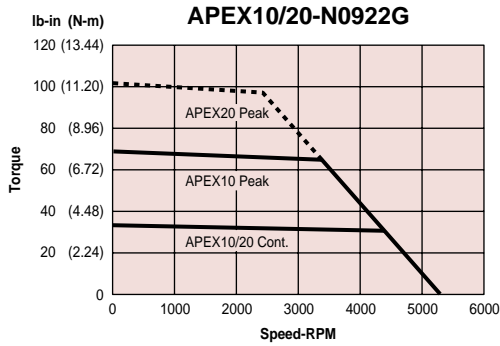
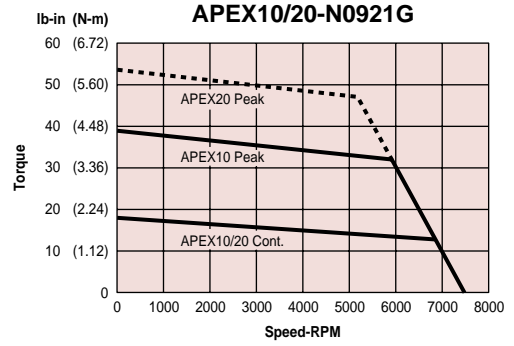
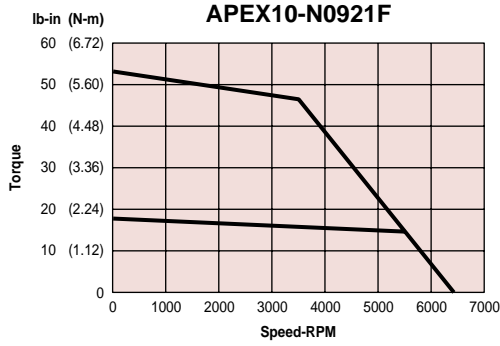

Motor Specifications – Compumotor 70mm NeoMetric Series Motors

The specifications table shows motor characteristics. Torque specifications are with rated and peak current for the *motors*. Rated and peak current for the *drive* may be lower — thus, torque may be lower. Consult the specifications table for *motor* capabilities. Consult the speed/torque curves for APEX10/20 system capabilities.

Parameter	Symbol	Units	N0701DR	N0701FR	N0702ER	N0702FR	N0703FR	N0703GR	N0704FR	N0704GR
Stall Torque Continuous ^{1,2}	T _{CS}	lb-in	6.40	6.40	11.90	11.90	18.00	18.00	22.20	22.20
		N-m	0.72	0.72	1.34	1.34	2.03	2.03	2.50	2.50
Continuous Stall Current ¹	I _{CS}	amperes-rms	2.65	4.14	3.05	4.24	4.17	5.79	4.30	5.96
Rated Speed	ω _r	rpm	7,500	7,500	6,480	7,500	5,800	7,500	4,900	7,000
		rps	125	125	108	125	98	125	82	117
Peak Torque ¹	T _{pk}	lb-in	19.20	19.20	35.60	35.60	54.00	54.00	66.60	66.60
		N-m	2.17	2.17	4.02	4.02	6.10	6.10	7.50	7.50
Peak Current, rms ^{1,6}	I _{pk}	amperes	7.90	12.40	9.10	12.70	12.50	17.40	12.90	17.90
Torque @ Rated Speed ¹	T _C	lb-in	5.80	5.80	9.40	10.40	14.50	15.40	17.50	17.50
		N-m	0.66	0.66	1.06	1.18	1.64	1.74	1.98	1.98
Rated Power-Output Shaft ¹	P _o	watts	510	515	718	919	1,004	1,367	1,014	1,450
Voltage Constant ^{3,4}	K _b	volts/radian/sec	0.221	0.14	0.353	0.253	0.392	0.282	0.468	0.338
Voltage Constant ^{3,4}	K _v	volts/KRPM	23.11	14.67	36.97	26.52	40.99	29.54	49.02	35.36
Torque Constant ^{3,4}	K _t	lb-in/amp rms	2.43	1.55	3.89	2.80	4.32	3.11	5.17	3.73
Resistance ³	R	ohms	5.52	2.27	5.22	2.70	3.36	1.74	3.47	1.80
Inductance ³	L	millihenries	12.98	5.23	15.86	8.16	12.13	6.30	14.50	7.55
Thermal Resistance ¹	R _{th}	°C/watt	1.44	1.44	1.15	1.15	0.96	0.96	0.87	0.87
Motor Constant	K _m	lb-in/√watt	0.83	1.03	1.70	1.70	2.36	2.36	2.77	2.78
Viscous Damping	B	lb-in/Krpm	0.0438	0.0438	0.050	0.050	0.0563	0.0563	0.0625	0.0625
Torque - Static Friction	T _f	oz.in.	1.40	2.10	2.10	2.80	2.80	2.80	3.50	3.50
Thermal Time Constant ⁷	τ _{th}	minutes	45	45	45	45	45	45	45	45
Electrical Time Constant	τ _e	milliseconds	2.35	2.35	3.03	3.03	3.61	3.61	4.19	4.19
Mechanical Time Constant	τ _m	milliseconds	1.60	1.60	0.88	0.88	0.62	0.62	0.56	0.56
Rotor Inertia	J	lb.in.sec ²	0.000128	0.000128	0.000196	0.000196	0.000262	0.000262	0.000329	0.000329
Weight	#	pounds	3.54	3.54	4.53	4.53	6.04	6.04	7.28	7.28
Winding Class			H	H	H	H	H	H	H	H

¹ @25°C ambient with 10 x 10 x 0.25 in. mounting plate, 150°C winding temperature. For 40°C ambient operation, reduce values by 12%

² RMS current through a single phase of a sinusoidally driven motor

³ ±10%, line-to-line, inductance bridge measurement method @ 1 kHz

⁴ Peak value

⁵ +/-30% line-to-line, inductance bridge measurement @ 1KHz

⁶ Peak current for 2 seconds maximum with initial winding temperature of 40° C.

⁷ Per NEMA specifications. For I²t considerations, use 10 minutes.

All specifications are subject to engineering change

Motor Specifications – Compumotor 92mm NeoMetric Series Motors

The specifications table shows motor characteristics. Torque specifications are with rated and peak current for the *motors*. Rated and peak current for the *drive* may be lower — thus, torque may be lower. Consult the specifications table for *motor* capabilities. Consult the speed/torque curves for APEX10/20/40 system capabilities.

Parameter	Symbol	Units	N0921F	N0921G	N0922G	N0922J	N0923H	N0923K	N0924J	N0924K
Stall Torque Continuous ^{1,4}	T_{CS}	lb-in	17.7	17.7	34.3	34.3	46.6	46.6	62.5	62.5
		N-m	2.0	2.0	3.88	3.88	5.26	5.26	7.06	7.06
Continuous Stall Current ^{1,2}	I_{CS}	amperes-rms	3.77	5.22	5.6	8.67	7.89	13.85	8.64	12.07
Rated Speed	ω_r	rpm	5,700	7,500	4,375	6,975	4,350	7,500	3,325	4,825
		rps	95	125	72.9	116.2	72.5	125	55.4	80.4
Peak Torque ¹	T_{pk}	lb-in	53	53	103	103	140	140	188	188
		N-m	5.99	5.99	11.6	11.6	15.8	15.8	21.2	21.2
Peak Current, rms ^{1,6}	I_{pk}	amperes	11.3	15.7	16.8	26	23.7	41.6	25.9	36.2
Torque @ Rated Speed ¹	T_c	lb-in	14.0	14.7	27.0	27.0	36.2	36.3	49	47.7
		N-m	1.58	1.66	3.05	3.05	4.09	4.1	5.5	5.39
Rated Power-Output Shaft ¹	P_o	watts	946	1,305	1,397	2,231	1,864	3,222	1,930	2,731
Voltage Constant ^{3,4}	K_b	volts/radian/sec	0.427	0.309	0.556	0.360	0.540	0.305	0.657	0.470
Voltage Constant ^{3,4}	K_v	volts/KRPM	44.66	32.27	58.18	37.69	56.54	31.96	68.83	49.17
Torque Constant ^{3,4}	K_t	lb-in/amp rms	4.71	3.41	6.13	3.97	5.96	3.37	7.25	5.18
Resistance ³	R	ohms	3.72	1.94	2.32	0.96	1.28	0.42	1.22	0.62
Inductance ³	L	millihenries	17.11	8.99	14.72	6.18	14.95	4.78	20.60	10.51
Thermal Resistance ¹	R_{th}	°C/watt	1.06	1.06	0.77	0.77	0.70	0.70	0.62	0.62
Motor Constant	K_m	lb-in/√watt	1.96	2.45	4.03	4.04	5.26	5.22	6.58	6.57
Viscous Damping	B	lb-in/Krpm	0.075	0.075	0.087	0.087	0.100	0.100	0.1125	0.1125
Torque - Static Friction	T_f	oz.in.	4	4	6	6	8	8	10	10
Thermal Time Constant ⁷	τ_{th}	minutes	60	60	60	60	60	60	60	60
Electrical Time Constant	τ_e	milliseconds	4.6	4.6	6.4	6.4	11.5	11.5	16.9	16.9
Mechanical Time Constant	τ_m	milliseconds	1.13	1.13	0.64	0.64	0.5	0.5	0.41	0.41
Rotor Inertia	J	lb.in.sec ²	0.000532	0.000532	0.000792	0.000792	0.00106	0.00106	0.00132	0.00132
Weight	#	pounds	8.1	8.1	11.7	11.7	15.1	15.1	18.0	18.0
Winding Class			H	H	H	H	H	H	H	H

¹ @25°C ambient with 10 x 10 x 0.25 in. mounting plate, 150°C winding temperature.

² RMS current through a single phase of a sinusoidally driven motor

³ ±10% line-to-line

⁴ Peak value

⁵ +/-30% line-to-line, inductance bridge measurement @ 1KHz

⁶ Peak current for 2 seconds maximum with initial winding temperature of 40° C.

All specifications are subject to engineering change

Connecting NeoMetric Motors

Motor Power

Connector Terminal	NeoMetric Motor Cable Color Code
Phase A	Red/Yellow
Phase B	White/Yellow
Phase C	Black/Yellow
Motor Ground *	Green/Yellow
Shield *	Unshielded

* **Motor Ground** and **Shield** are connected internally to the **Earth** terminal on the AC power connector

Motor Feedback

	NeoMetric Resolver & Cable Color Code
Shield	Uninsulated
Cos	Red
	Black
Sin	Green
	Blue
Ref	Brown
	White
	Yellow
MT+	Yellow
MT-	Yellow
Flt Relay+	
Flt Relay-	
NC	
NC	

NeoMetric Motors — Electrically Released Brakes

Motor brakes are mounted internal to the motor. When ordering the brake option, specify the motor type.

Brakes	70mm or 34 frame	92mm
Static rated torque	24 in-lb	72 in-lb
Coil voltage	24 VDC	24 VDC
Coil current	0.8 amps	0.52 amps
Weight	1.0 lbbs	2.51 lbs
Inertia	0.000038 lbs-in-sec ²	0.00015 lb-in-sec ²

APEX, SM and NeoMetric Motor Resolver Specifications

Parameter	Value
Input voltage @ 7000 Hz	4.25 volts
Input current, max.	55 ma
Input power, nominal	0.12 watts
Impedance ZSO (@90°)	58+j145 ohms
Impedance ZRO	53 +j72 ohms
Impedance ZRS	42 +j55 ohms
Transformation ratio	0.470 ±5%
Output voltage	2.0 ±5% volts
D.C. rotor resistance	23 ±10% ohms
D.C. stator resistance	19 ±10% ohms
Sensitivity	35mV/Degree
Max. Error from EZ	±10 minutes
Phase shift, open circuit	5° leading ±3"
Null voltage (total)	20 mV rms
Impedance ZSS	50 +j128 ohms
Inertia	included in motor specification

Dimensions — Compumotor NeoMetric Series Motors, 70mm

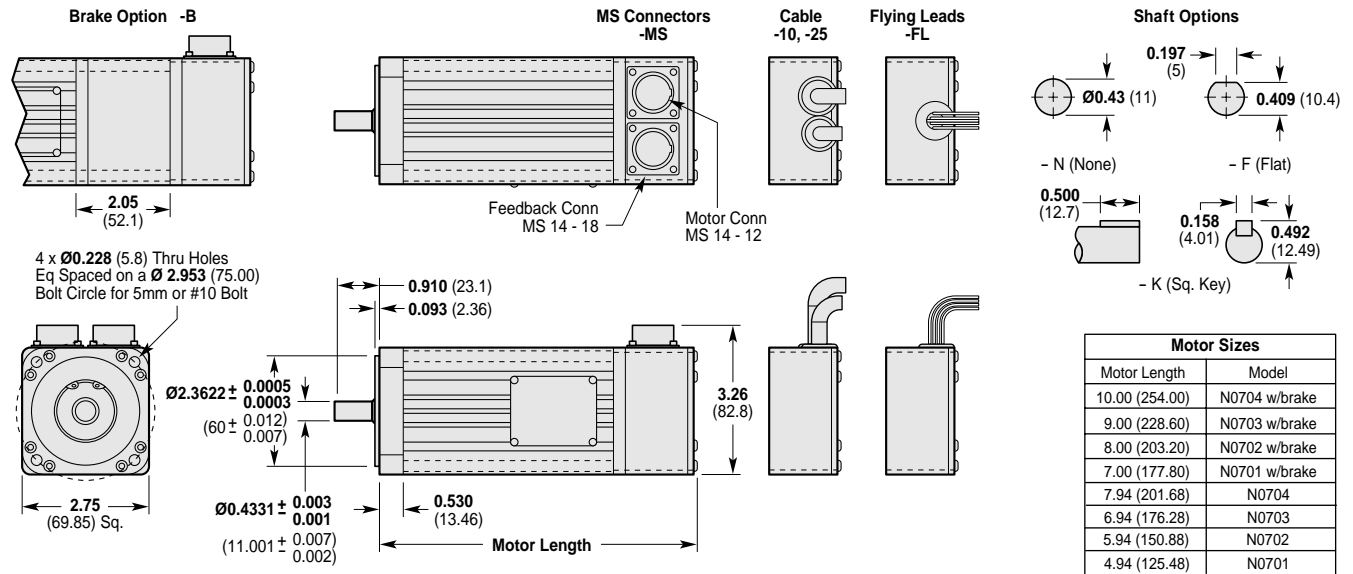

Dimensions — Compumotor NeoMetric Series Motors, 92mm

