

CHAPTER ONE

Introduction

IN THIS CHAPTER

- Introduction
 - APEX Drive Description and Block Diagram
-

INTRODUCTION

This user guide describes three products.

- ❑ APEX10 Servo Drive – 16A peak, 8A continuous; 1-phase AC input
- ❑ APEX20 Servo Drive – 24A peak, 12A continuous; 1- or 3-phase AC input
- ❑ APEX40 Servo Drive – 40A peak, 20A continuous; 1- or 3-phase AC input

NAMES IN THIS USER GUIDE

The drives listed above have many identical features. In this manual, when we describe features that are the same on each drive, we will use the name **APEX Drive**. When we describe features that are not the same on all drives, we will identify each by its full name—**APEX10 Drive**, **APEX20 Drive**, or **APEX40 Drive**. This will help call attention to differences between the drives.

APEX DRIVE0 – DESCRIPTION AND BLOCK DIAGRAM

The APEX Drive is a sinusoidal servo drive designed to run three phase brushless DC servo motors equipped with resolvers. The block diagram for a typical system is shown below.

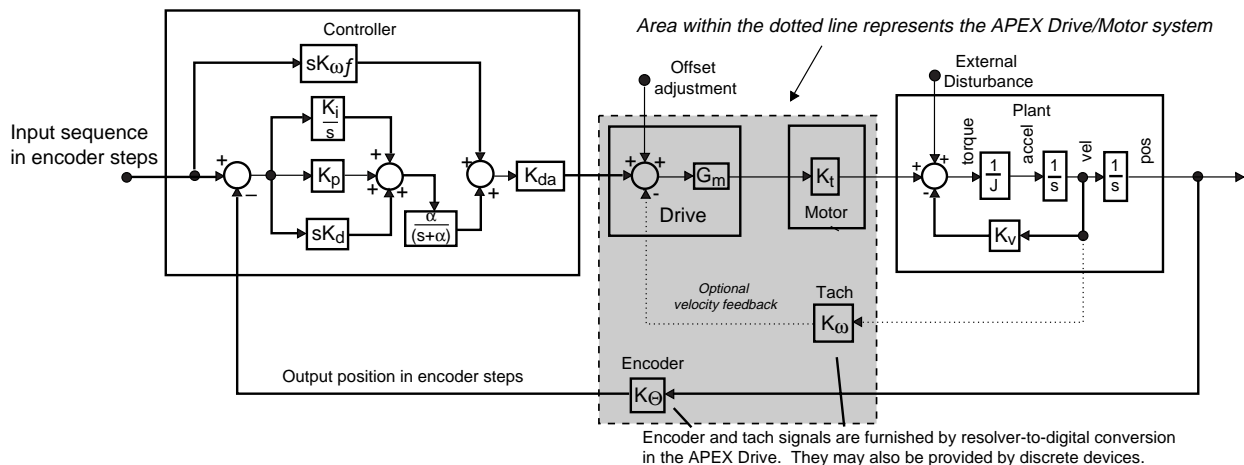

System Block Diagram

Output from the controller to the drive is an analog voltage that can range from -10VDC to +10VDC. This is a *torque command* that represents commanded current. The drive will produce output current to the motor that is proportional to the voltage level of the torque command.

Inside the APEX Drive (see the block diagram below), the torque command goes through input filtering and scaling circuitry, and on to a three phase power amplifier, where it is combined with commutation information from the motor. The power amplifier, an *insulated gate bipolar transistor* (IGBT) module, sends current of the correct phase and polarity to the motor. The amplifier contains pulse width modulation (PWM) and current loop feedback circuitry. The IGBT module also contains control and fault logic that drives the status LEDs and various inputs and outputs.

The drive has an internal regeneration resistor, and control circuitry that will automatically dissipate excess regenerated energy in the resistor. You can also install an external regeneration resistor to dissipate even more regenerated energy.

APEX DRIVE – BLOCK DIAGRAM

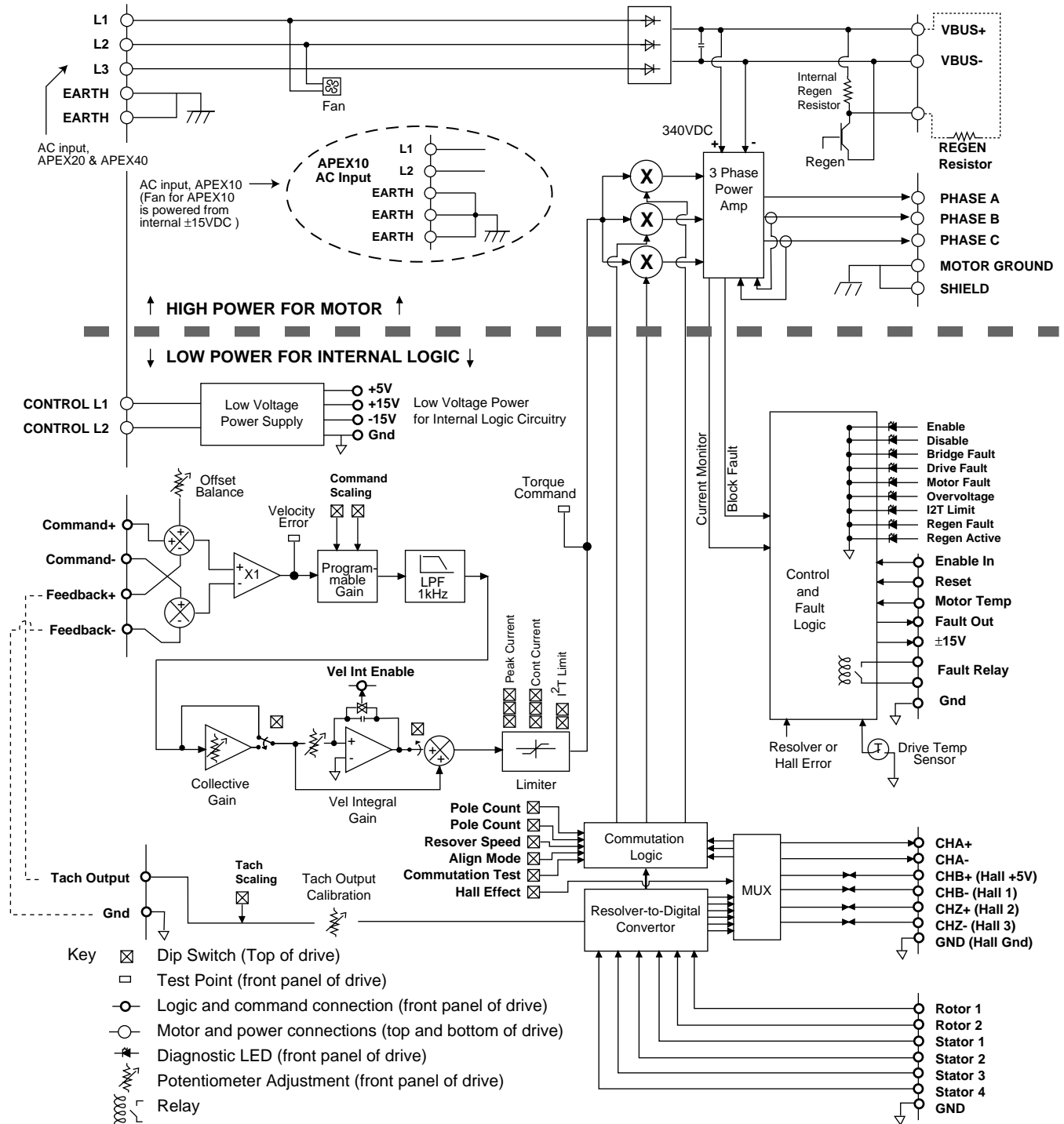

ADDITIONAL FEATURES

TWO AC POWER INPUTS

The drive has two AC inputs. One provides power for motor current, through the internal high-power three phase amplifier. The other input provides power for logic and control, through the internal low-voltage DC power supply. With these two separate inputs, you can remove power from the motor, but continue to power internal control circuits.

TORQUE MODE OR VELOCITY MODE

Most users will operate the drive with a servo controller, such as Compumotor's 6250 Servo Controller. With this type of controller, we recommend operating the drive in torque mode. This provides the best performance, and eliminates the need for tuning at the drive.

You can operate the drive in velocity mode if you use a P type controller (as opposed to PID type controller), or if you need to control the velocity of a spindle with an analog velocity command.

RESOLVER OR HALL EFFECT

The default setup for the Apex drives is to use a resolver for commutation. Encoder signals for feedback are also derived from the resolver information; however, a motor with Hall effects and an encoder can be used in place of a motor with a resolver.

DIP SWITCHES

The APEX Drive has a bank of DIP switches located on top of the drive. You can set these switches to configure the drive for your particular application.

INPUTS AND OUTPUTS

All input and output signal connections are made on the front panel of the drive, through removable screw terminal connectors. The power and motor connections are separated (top and bottom of the drive) and recessed from the front panel for safety.

COMPUMOTOR SERVO MOTORS

Compumotor sells three models of servo motors with the APEX Drive.

- ❑ APEX Series Servo Motors
- ❑ SM Series Servo Motors
- ❑ NeoMetric Series Servo Motors

Each model is available in many different sizes. See *Chapter 4 Hardware Reference* for motor specifications and dimensions.

COMPUMOTOR FAMILY OF PRODUCTS

The APEX Drive is completely compatible with Compumotor's broad range of single-axis and multi-axis motion control products.