

DM1004B & DM1004C Motor Dimensions

DM1004B

Dimensions in inches (mm)

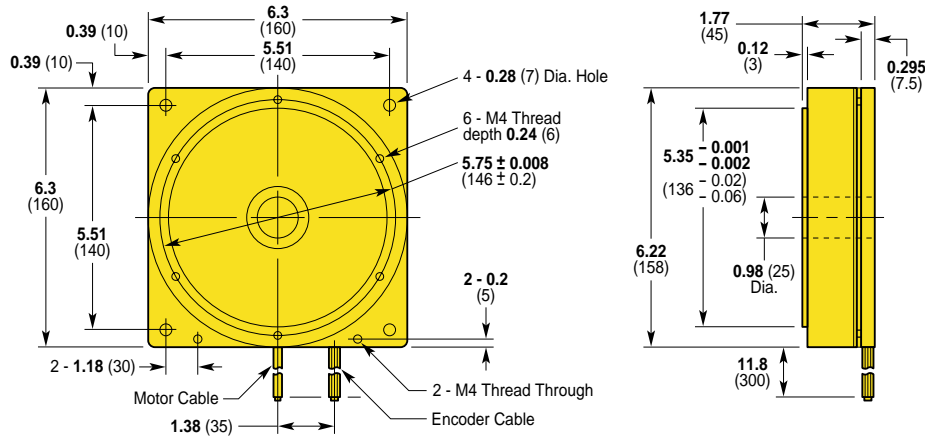

DM1004C

Dimensions in inches (mm)

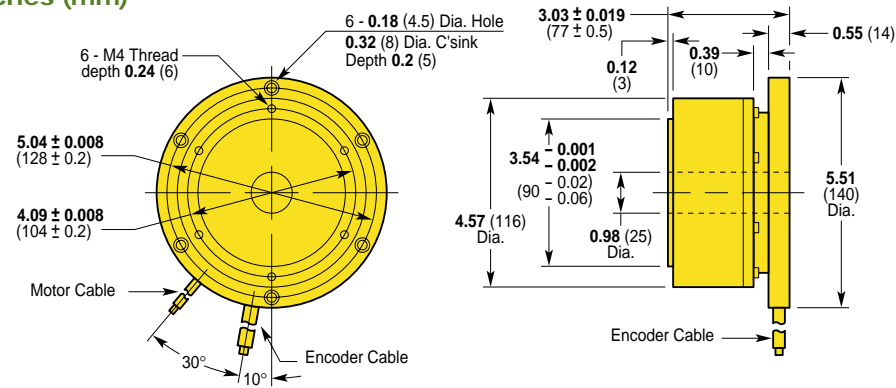

DM1004B & DM1004C Drive Dimensions

Dimensions in inches (mm)

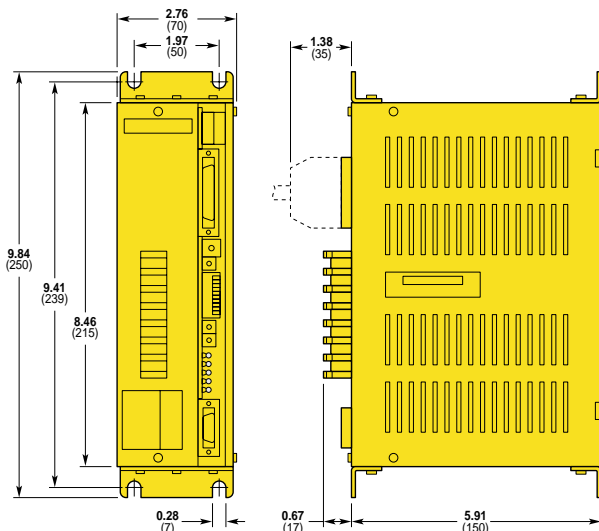

Speed/Torque Curve

The speed/torque curves represent peak torque available; continuous torques are approximately 2/3 of the peak value.

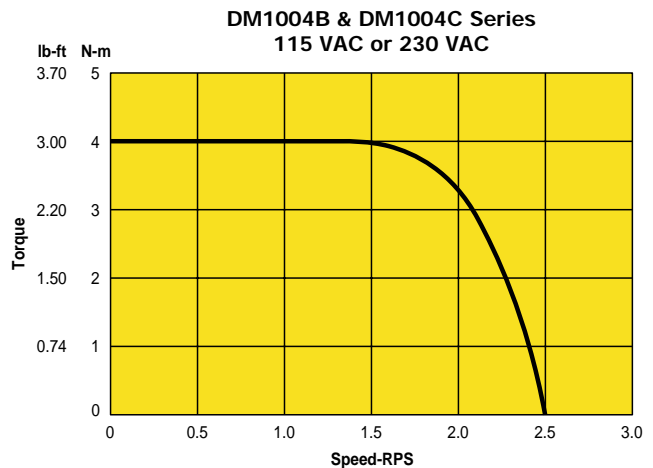

Integrate Direct Drive Servo Systems Into Your Next Application. Call 1-800-358-9070 Today.