

**DM Series – Motor Data**

	Model 1015B	Model 1030B	Model 1045B	Model 1050A	Model 1100A	Model 1150A	Model 1200A
<b>Peak torque</b>							
ft-lbs	11	22	33	37	74	111	148
(Nm)	(15)	(30)	(45)	(50)	(100)	(150)	(200)
<b>Rated speed</b>							
• rps							
115VAC	2.0	2.0	1.0	1.0	1.0	0.5	0.5
230VAC	2.0	2.0	2.0	1.0	1.0	1.0	1.0
<b>Rotor inertia</b>							
oz-in <sup>2</sup> x 10 <sup>2</sup>	6.6	8.2	10.4	52.5	65.1	77.6	91.3
(Kgm <sup>2</sup> ) x 10 <sup>-3</sup>	(12)	(15)	(19)	(96)	(119)	(142)	(167)
<b>Maximum steps/rev</b>	655,360	655,360	655,360	1,024,000	1,024,000	1,024,000	1,024,000
<b>Motor weight*</b>							
lbs	12	17	21	32	42	53	64
(kg)	(5.5)	(7.5)	(9.5)	(14.5)	(19)	(24)	(29)
<b>Maximum static axial load**</b>							
• Compression	lbs 6,600	6,600	6,600	8,800	8,800	8,800	8,800
• Tension	lbs 2,200	2,200	2,200	4,400	4,400	4,400	4,400
<b>Max. static overhung load**</b>	148	148	148	296	296	296	296
<b>Power Consumption load</b>	0.9/1.8	1.2/2.3	1.2/2.3	1.4/2.8	1.6/3.1	1.7/3.5	1.7/3.5
Max 115/230VAC							

\* Drive weight is 13.2 lbs (6 kgs)

\*\* When designing a system, de-rate the maximum load to the values shown at the right:

Application	De-rate Factor
Smooth, rotary motion	1/3
Intermittent press loading	1/5
Repetitive shock loading	1/10

**DM Series Motor Dimensions**

**DM-A Series**

Dimensions in inches (mm)

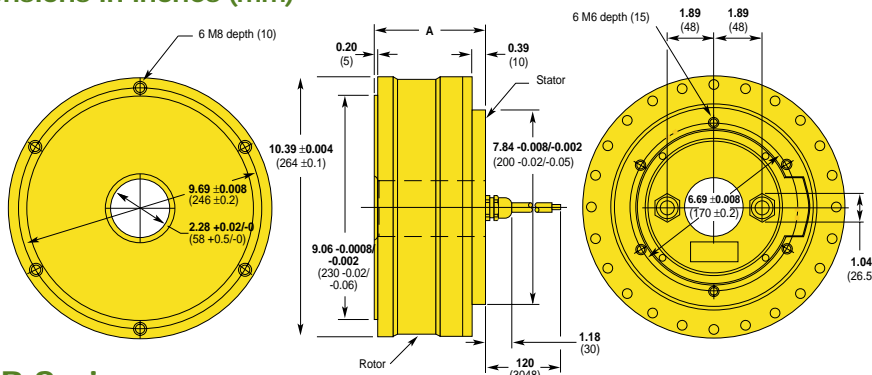

Model	A
DM1050A	4.45 ± 0.04 (113 ± 1)
DM1100A	5.43 ± 0.04 (138 ± 1)
DM1150A	6.42 ± 0.04 (163 ± 1)
DM1200A	7.40 ± 0.04 (188 ± 1)

**DM-B Series**

Dimensions in inches (mm)

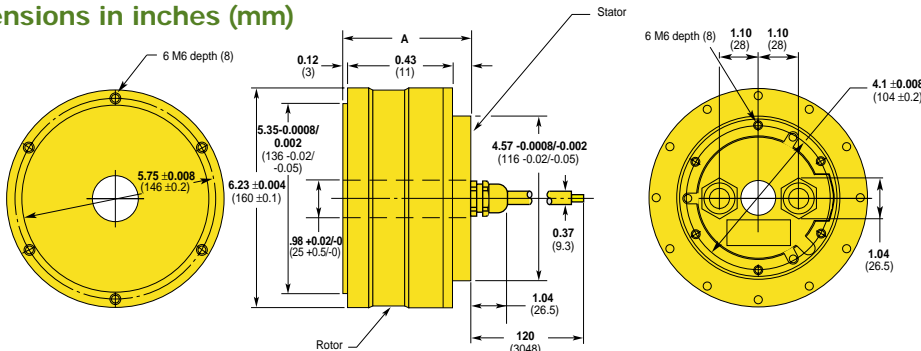

Model	A
DM1015B	3.62 ± 0.04 (92 ± 1)
DM1030B	4.65 ± 0.04 (118 ± 1)
DM1045B	5.63 ± 0.04 (143 ± 1)

**Integrate Direct Drive Servo Systems Into Your Next Application. Call 1-800-358-9070 Today.**