

## PDS Series

### Step/Direction Drives

PDS drives are appropriate in applications that require coordinated multi-axis motion control, interfacing to a user-supplied pulse source or applications that have very simple control functions. The PDS drives are frequently used on multi-axis applications with Compumotor 6000 Series indexers. The internal oscillator can solve some low-complexity applications without the additional expense of a PDX indexer/drive.

When the PDS drive is used with a Compumotor 6000 Series indexer, the drive is essentially a slave to the Step and Direction signals output by the 6000 Series indexer. The drive plugs directly into the cable supplied with the indexer; the only other configuration required is to select the appropriate motor current, motor resolution and standby mode. Selection of these parameters is by switches accessed through the front panel. All other system parameters are configured by software in the 6000 Series indexer.

Applications having simple control requirements could be solved with the PDS drive internal oscillator feature. The drive's internal oscillator is controlled by two inputs; slow and fast. When the slow input is active, the oscillator generates low-frequency pulses and slowly rotates the motor at a constant speed, when the input goes inactive the motor stops immediately. When the fast input is active, the oscillator generates high-frequency pulses and will rotate the motor at a higher speed. The fast speed range will ramp pulses to accelerate the motor. If the pulses were unramped, the motor would tend to stall. When the fast input is deactivated, the pulses will be ramped down to a stop. The speed of the step pulses is controlled by two potentiometers; one to control the slow range and one for the fast range. Another potentiometer is provided to adjust the fast speed ramp rate. A PLC can control the PDS drive Fast, Slow and Direction inputs solving some low-complexity applications.

#### Features

- Standardized Step/Direction/Shutdown inputs and Fault output
- Directly compatible with Compumotor 6000 Series controls
- Directly compatible with open-collector user supplied pulse sources
- Internal dual range speed-control oscillator
- Self-test rotates motor without supplying external pulse source

#### Diagram

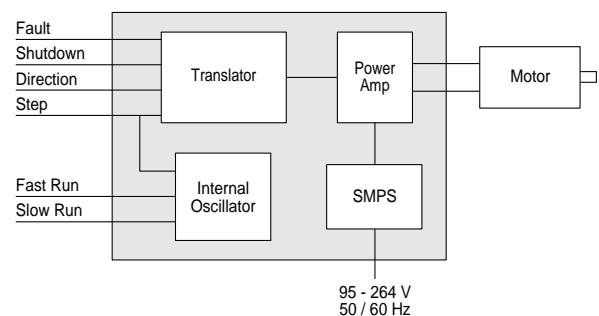

**PDS Specifications**

Parameter	Value
<b>AC Power Input</b>	
Connector	IEC 3-way, mating cable supplied
Supply voltage	95VAC - 264VAC (absolute limits)
Supply frequency	47 to 63Hz
Power factor	Better than 0.9 over full input voltage and output power range
<b>Performance</b>	
Resolution	Switch selectable: 400, 1,000, 2,000 and 4,000 steps/rev
Speed/Torque	Curves located on page C49; CE motors located on page C52.
<b>Motors</b>	
Type	2-phase hybrid or permanent magnet
Step angle	Typically 1.8°, but 0.9°, or 3.6° and others acceptable
Motion	Linear or rotary movement
Number of leads	4, 6 or 8 (5 lead not suitable)
Inductance	Min. 1MH, max. 30MH: recommend 1-10MH
<b>Amplifier</b>	
Type	20KHz fixed frequency, bi-polar recirculating current control using ultra-low $R_{ds(on)}$ MOSFETs
DC Bus voltage	70VDC
Nominal current	One-phase-on or peak current level 0.9-3.0A (PDS/X13), 2.5-5.0A (PDS/X15)
Standby	Current is normally reduced to 80% of nominal when the motor is stopped. Reduction of 50% can be selected with the standby switch
Protection	Drive shuts down and signals a fault in any of the conditions listed
Short-circuit	Across and between phase and phase to GND
Brownout	If DC Bus <50VDC
Overvoltage	If DC Bus >90VDC
Internal supplies	Any internal supply out of specification
Overtemperature	If internal temperature >90° (194°F)
Self-Test	Rotates motor at SLOW speed setting
Diagnostics	Power LED (green); Fault LED (red) and Fault Output
Reset	Faults reset by Shutdown input; power-up reset time 2 sec
<b>Step/Direction Mode</b>	
	Differential TTL opto-isolated inputs. On current = 10mA min., 21mA max.; voltage low = 0.4V max.; voltage high = 3-5.0V
Step Input	Drive steps on high-low transition; Min. step pulse width 1μS; Max. frequency 200KHz
Direction Input	Motor direction changes on transition; Direction input must change at least 2.5μS before step pulse
Shutdown Input	Motor shutdown when input high; Fault latch reset on high-low transition
Fault Output	Opto-isolated NPN transistor Fault + = Collector, Fault - = Emitter; Transistor ON during Fault conditions $V_{ce(sat)} = +1.0V$ max. at 5mA; $V_{ce(max)} = +24V$ max.; $I_{max} = 5mA$
Aux Clock Input	Single-ended step input, 4k7 pull-up to +12V; Voltage low: 0 to +2.0V or short to gnd; Voltage high: +10V to +12V or open circuit; Negative going pulses, steps on high-low transition
Aux DIR Input	Single-ended direction input, 4k7 pull-up to +12V Voltage low: 0 to +2.0V or short to gnd; Voltage high: +10V to +12V or open circuit
<b>Oscillator Mode</b>	
Slow Input	Active low; Low voltage <2.0V High voltage open-circuit, internally pulled-up to 12V
Fast Input	Active low; Low voltage <2.0V High-voltage open-circuit, internally pulled-up to 12V
Aux DIR Input	Controls motor direction; Low-voltage <2.0V High-voltage open-circuit, internally pulled-up to 12V
Slow speed range	0.05 rps-2.0 rps, unramped; Internal slow potentiometer or external 100K potentiometer
Fast speed range	1 rps-50 rps ramped; Internal fast potentiometer or external 10K potentiometer
Ramping	Acceleration/Deceleration of Fast speed only 20-500 rps <sup>2</sup>
Internal clock-out	NPN transistor: Open-collector, emitter = GND; Low going pulse for every pulse generated by the oscillator; Output pulse width = 1μS (fixed); $V_{ce(sat)} = 0.25V$ at $I = 10mA$ ; $V_{ce(max)} = 24V$ ; $I_{max} = 15mA$
<b>Physical</b>	
Drive dimensions	Height 9.8" (250mm), width 2" (50mm), depth 7.5" (190mm); Drawings located on page C55
Weight (Drive only)	Net 4 lbs (1.8Kg); Ship 5.7 lbs (2.6Kg)
<b>Environmental</b>	
Operating temperature	0°C to 40°C (32°F to 104°F)
Storage temperature	-40°C to 85°C (40°F to 185°F)
Relative Humidity	0% to 95% (non-condensing)
Ingress protection	IP20
Mounting	Panel mount. Vertical mounting only; Mounting slots for #8 (M4) Allen Cap or Fillister/Pan Head screws