



and (LVD)

## APEX6151, APEX6152 and APEX6154

Compumotor's APEX6151, APEX6152 and APEX6154 are stand-alone, single-axis servo drive/controller systems. The APEX6151, APEX6152 and APEX6154 pack all the power and reliability of the 6000 family of controllers and APEX series of drives into one convenient package. All of the I/O points, RS-232C control, operator interface options and following capabilities for single-axis applications are included. The following package can perform phase shifts, electronic gearbox, and flying cutoff functionality with ease. The APEX6151, APEX6152 and APEX6154 are designed to solve single-axis applications cleanly and completely. For multiple-axis applications, up to 99 APEX6151, APEX6152 and APEX6154s can be daisy chained to work together.

In order to speed your application development, the APEX6151, APEX6152 and APEX6154 come standard with Motion Architect, a Microsoft Windows-based development software. Motion Architect contains many tools which allow you to easily create and implement motion programs. The optional Servo Tuner module for Motion Architect allows you to gather and display real-time move information. You can see the results of changing tuning values to optimize motion profiles. The APEX6151, APEX6152 and APEX6154 are also compatible with Motion Toolbox™ and DDE Server.

The APEX6151, APEX6152 and APEX6154 use the 6000 Series command language. This popular language is powerful enough to implement complex motion control applications and simple enough to not overwhelm the novice programmer. The APEX6151, APEX6152 and APEX6154 are your single-axis solutions!

### Features

#### Performance

- One axis of packaged servo control
- Programmable update rates for servo loop as fast as 205 microseconds
- Accepts brushless resolver feedback or hall effect sensors for commutation
- Digital Signal Processor (DSP) for servo control (PIV with velocity and acceleration feed-forward)
- 1.2 MHz post-quadrature position feedback frequency

### Protection

- Over temperature, over voltage, short circuit protected
- Internal power dump circuit to dissipate regenerated power from motor
- Motors include over-temperature sensor

### I/O

- Home limit, positive and negative end-of-travel limits
- 16 programmable inputs and 8 programmable outputs
- Auxiliary high-speed, programmable inputs (2) and output (1) providing position capture or output on position to  $\pm 1$  count at maximum encoder frequency

### Language

- Dedicated hardware registers for commanded position, I/O, system status, axis status, and encoder position
- Position-based following
- Capability to interrupt program execution on error conditions
- Variable storage, conditional branching, and math capability
- Program debug tools—trace mode, break points, and simulation of I/O
- Scaling of distance, velocity and acceleration
- S curve or trapezoidal motion profiling
- 150,000 bytes of nonvolatile memory for storage of programs and paths

### Software Provided

- Motion Architect, Microsoft Windows-based application development software

### Optional Software

- Servo Tuner provides graphical feedback of real-time motion information to make determining tuning gains simplistic
- Motion Toolbox library of LabVIEW virtual instruments (VIs) for icon-based programming of Compumotor's 6000 Series controllers with LabVIEW
- Motion Builder provides a visual development environment for graphical icon-based programming of the 6000 Series products.

### Interface Capability

- Operates stand-alone or interfaces to computers or programmable logic controllers
- Compatible with RP240 operator interface panel
- Two RS-232C communications ports

### Physical

- Stand-alone package
- Nine diagnostic LEDs
- Same voltage input as APEX10/20/40



Software information is  
available on page B109.

Parameter	Value		
<b>Performance</b>			
Position Range	±2,147,483,648 counts		
Velocity Range	0.001 to 200 units/sec		
Acceleration Range	0.001 to 9999.9999 units/sec <sup>2</sup>		
Velocity Accuracy	±0.02% of maximum rate		
Velocity Repeatability	±0.02% of set rate		
Motion Trajectory Update Period	Default is 860 μs (depends on SSFR value)		
Servo Sampling Update Period	Default is 215 μs (depends on SSFR value)		
System Update Period	Default is 1.7 ms (depends on SSFR value)		
Repeatability	±5 arcmin		
Resolver Accuracy	±22 arcmin		
Resolution	4096 post-quadrature counts		
<b>Output Power</b>			
	<b>APEX6151</b>	<b>APEX6152</b>	<b>APEX6154</b>
Voltage	170-340VAC; 420VDC (max)	340VDC (nominal); 420VDC (max)	340VDC (nominal); 420VDC (max)
Frequency	0-400 Hz fundamental; (15 kHz PWM)	0-400 Hz fundamental; (8 kHz PWM)	0-400 Hz fundamental; (8 kHz PWM)
Current (max continuous)	8A continuous per phase sinusoidal (5.6.5A rms); 16A peak per phase sinusoidal (11.3A rms)	12A continuous per phase sinusoidal (8.5A rms); 24A peak per phase sinusoidal (17.0A rms)	20A continuous per phase sinusoidal (14.14A rms); 40A peak per phase sinusoidal (28.3A rms)
<b>Input Power</b>			
	<b>APEX6151</b>	<b>APEX6152</b>	<b>APEX6154</b>
Motor Supply Voltage	120-240VAC (1-phase)	205-252VAC (1- or 3-phase)	205-252VAC (1- or 3-phase)
Frequency Range	47-66 Hz	47-66 Hz	47-66 Hz
Current (max continuous)	10A (rms) @ 120VAC single phase; 10A (rms) @ 240VAC single phase	8A (rms) 3-phase	15A (rms) 3-phase
Power (max continuous)	3.4 KVA	4.8 KVA	8.5 KVA
Fuses		No internal fuses. Recommend external fuse.	
Isolation Transformer	Not required	Not required	Not required
Logic Supply Voltage	85-252 (1-phase)	85-252 (1-phase)	85-252 (1-phase)
Frequency Range	47-66 Hz	47-66 Hz	47-66 Hz
Current (max continuous)	1.0A	1.0A	1.0A
Power (max continuous)	0.08 KVA	0.08 KVA	0.08 KVA
Fuses		3.0A 250VAC internal fuse. Not user replaceable.	
Isolation Transformer	Not required	Not required	Not required
<b>Protection</b>			
Short Circuit	Phase-to-phase, phase-to-ground		
Brownout	Below 100VAC		
Over voltage	385VDC (provision for power dump)		
Over temperature	Drive and motor		
I <sup>2</sup> T	Motor protection		
<b>Inputs (see also I/O pin-outs)</b>			
Home, pos/neg limits	POS NEG and HOM input switching voltage levels are determined by V <sub>I/O</sub> . Low ≤ [1/3 x (V <sub>I/O</sub> )] volts. High ≥ [2/3 x (V <sub>I/O</sub> )] volts. If V <sub>I/O</sub> is connected to a +5V power supply (internal or external), AUX-P can be connected to a supply of up to +24VDC. If V <sub>I/O</sub> is connected to an external +24VDC power supply, then AUX-P must also be at +24VDC (or at ISO GND).		
External Incremental Encoder	Differential comparator accepts 2-phase quadrature incremental encoders with differential (recommended) or single-ended outputs (+5VDC HCMOS-compatible**). Maximum frequency = 1.2 MHz, minimum time between transitions = 833 ns.		
16 Programmable	HCMOS-compatible** with internal 6.8 kΩ, pull-up (connect IN-P to GND to sink current). Voltage range = 0 to 24V, 50-pin plug is compatible with OPTO-22™ signal conditioning equipment. Controllable with the 6000 Series programming language.		
Two trigger inputs	APEX6151, 6152, 6154 have HCMOS-compatible** high-speed inputs for position capture and general purpose functions		
<b>Outputs (see also I/O pin-outs)</b>			
8 Programmable	HCMOS-compatible,** open collector output. Can be pulled up by connecting OUT-P to +5V on the auxiliary board, or to user-supplied voltage of up to 24V. Max. current in ON state (sinking) = 300mA, 50-pin plug is comparable with OPTO-22™ signal conditioning equipment		
One Auxiliary Output	Open collector high-speed output for output on position & general purpose functions.		
<b>Environment</b>			
Operating Temperature	32°F to 122°F (0° to 50°C)		
Storage Temperature	-22°F to 185°F (-30°C to 85°C)		
Max Heat Sink Temperature	162°F (75°C)		
Max Motor Case Temperature	257°F (125°C)		
Motor Temperature	32°F to 104°F (0° to 40°C)		
Humidity	0 to 95% non-condensing		

\* For operation from single-phase power, derate system performance as shown in motor speed torque curves.

\*\* HCMOS-compatible voltage levels: Low ≤ 1.0V; High ≥ 3.25V

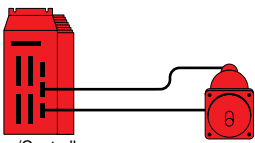

Drive/Controller

## Command Language (partial list)

The APEX6151, APEX6152 and APEX6154 are easily programmed with the 6000 Series language. Each command is an ASCII character mnemonic with numeric parameters for the axis following the command. The following command example sets velocity to 10 revolutions per second: V10.

### Conditionals

Command	Description
IF()	If Statement
REPEAT	Repeat Statement
WAIT()	Wait for a Specific Condition
WHILE()	While a Condition is True
GOWHEN()	Initiate a move based on a condition

### Display [RP240]

Command	Description
DCLEAR	Clear Display
DPCUR	Position Cursor
DREAD	Read Display Entry
DVAR	Display Variable
DWRITE" "	Write String to Display

### Following

Command	Description
FOLEN	Enable following
FOLMAS	Define master axes
FOLMD	Define master move distance
FOLRN	Set following ratio numerator
FOLRD	Set following ratio denominator
FSHFD	Initiate preset phase shift
FSHFC	Initiate continuous shift

### Homing

Command	Description
HOM	Go Home
HOMA	Home Acceleration
HOMAD	Home Deceleration
HOMBAC	Home Backup Enable
HOMDF	Home Direction Final
HOMEDG	Home Reference Edge
HOMFV	Home Final Velocity
HOMLVL	Home Active Level
HOMV	Home Velocity
HOMZ	Home to Z-channel Enable

### I/O

Command	Description
INFEN	Enable Input Functions
INFNC	Input Function
OUTFNC	Output Function
OUT	Turn On/Off Outputs

### Limits

Command	Description
LH	Hard Limit Enable
LHAD	Hard Limit Deceleration
LHLVL	Hard Limit Active Level
LS	Soft Limit Enable
LSAD	Soft Limit Deceleration
LSCCW	Soft Limit CCW Range
LSCW	Soft Limit CW Range



Software information is available on page B109.

### Miscellaneous

Command	Description
;	Comment
DRIVE	Drive Enable
ERRORP	Error Program
L	Loop
MA	Absolute / Incremental Mode Enable
MC	Preset / Continuous Mode Enable
PSET	Define Position Counter
READ	Read a Value from Terminal
TIMST	Reset and Start Timer
STEP	Single Step Mode Enable
WRITE" "	Transmit a String to Terminal

### Motion

Command	Description
A	Acceleration
AA	Acceleration Average (for S curves)
AD	Deceleration
ADA	Deceleration Average (for S curves)
D	Distance
GO	Initiate Motion
S	Stop
V	Velocity

### Scaling

Command	Description
SCLA	Accel / Decel Scale Factor
SCLD	Distance Scale Factor
SCLV	Velocity Scale Factor

### Servo Tuning

Command	Description
SGAF	Acceleration Feedforward Gain
SGL	Integral Feedback Gain
SGP	Proportional Feedback Gain
SGSET	Save a Set of Servo Gains
SGV	Velocity Feedback Gain
SGVF	Velocity Feedforward Gain
SOFFS	Servo Command Offset

### Subroutines

Command	Description
DEF	Define a Subroutine
GOSUB	Execute a Subroutine with Return
GOTO	Execute a Subroutine without Return

### Transfer Information

Command	Description
TAS	Transfer Axis Status
TANV	Transfer Analog Input Value
TIN	Transfer Input Status
TLIM	Transfer Limit Status
TOUT	Transfer Output State
TPER	Transfer Position Error
TPE	Transfer Position of Encoder
TPC	Transfer Position Commanded

**Speed/Torque Curves for SM and NeoMetric Motors**

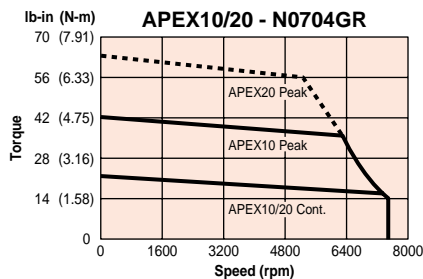
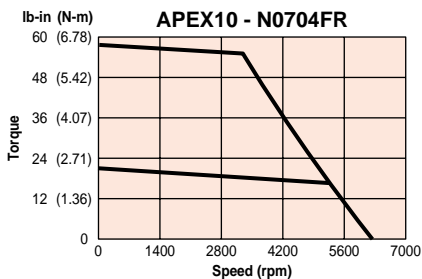
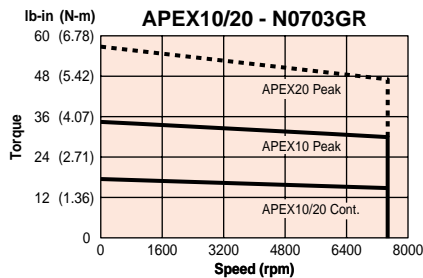
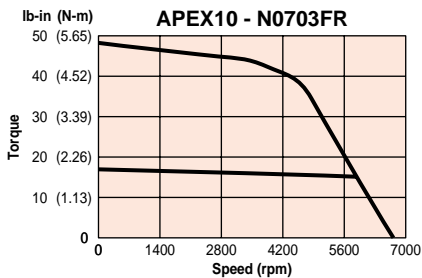
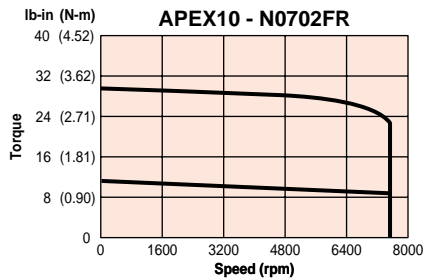
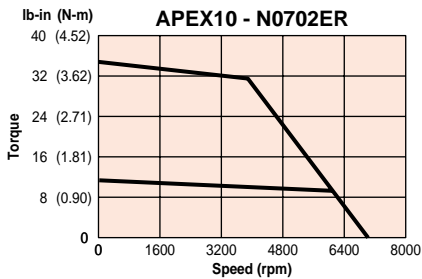
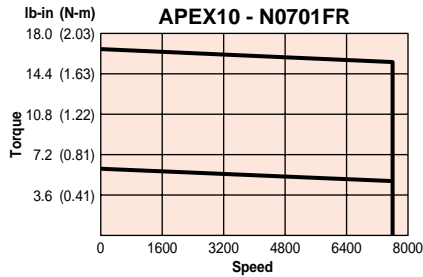
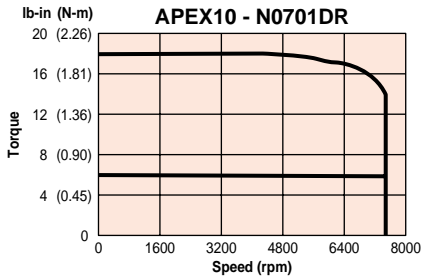
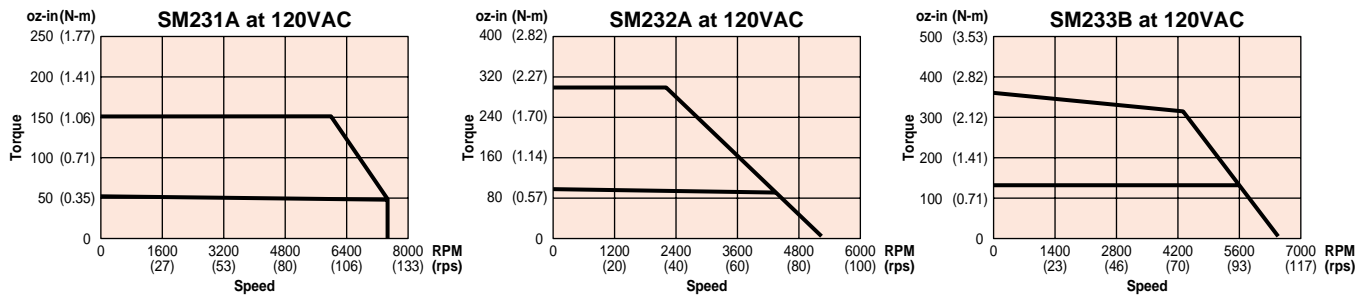

All APEX torque/speed data assume the following conditions:

- the performance of APEX10 = APEX6151; APEX20 = APEX6152 and APEX40 = APEX6154
- 40°C ambient temperature
- nominal  $K_t$  of motor
- SM-231A through 610: motor on aluminum heat sink = 8.0" x 12.0" x 0.25"

- 620 through 640: motor on aluminum heat sink = 12.0" x 12.0" x 0.75"
- All SM motor speed/torque data obtained with APEX10 or APEX6151 at 120VAC. All NeoMetric motor speed/torque data obtained with indicated drive at 240VAC.

**B Servo Systems**

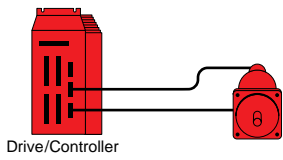

## APEX10/20/40 Speed/Torque Curves

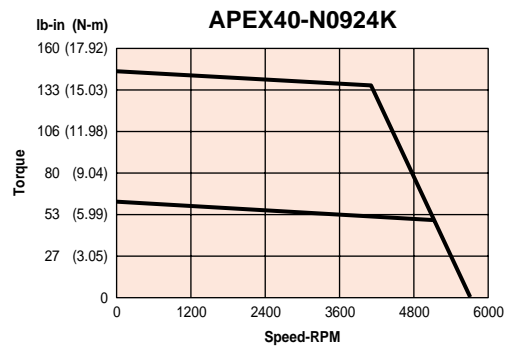
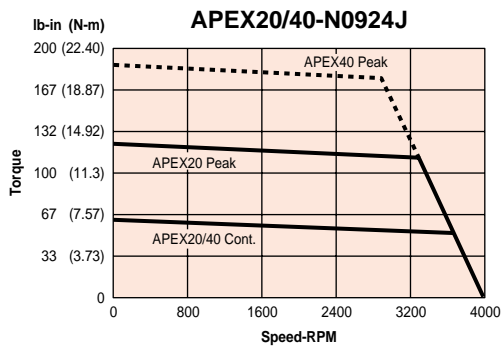
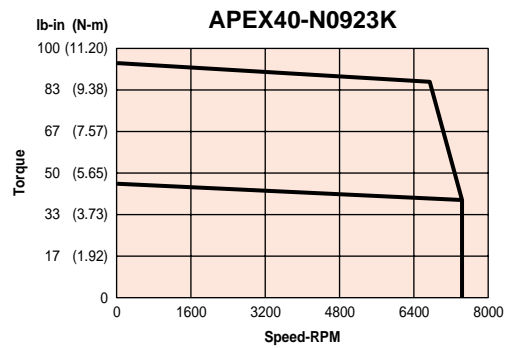
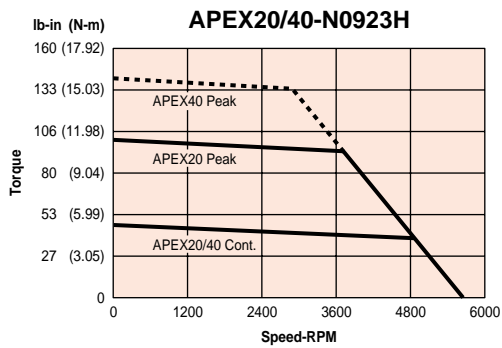
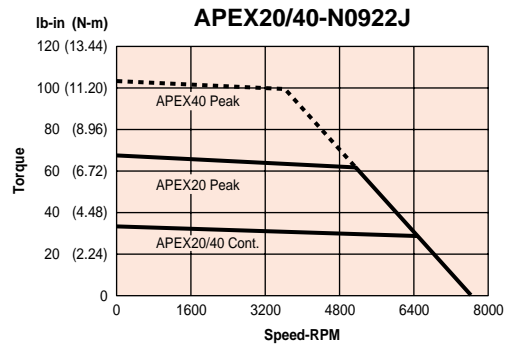
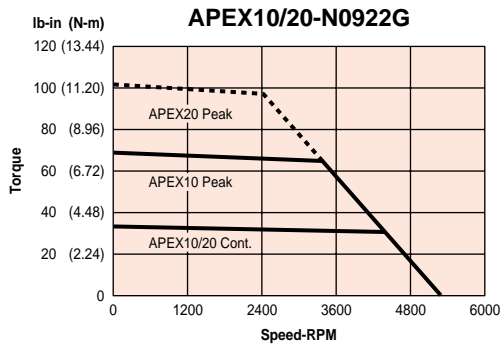
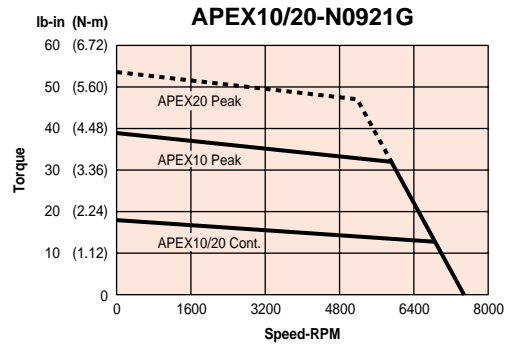
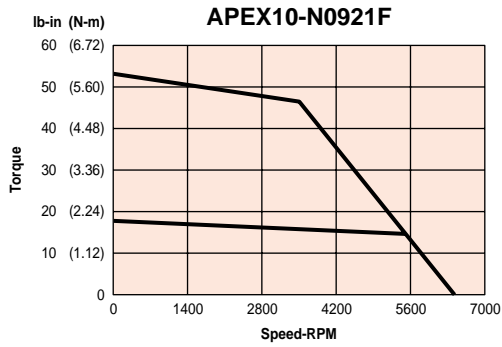

**Motor-Only Technical Data SM and 70 mm NeoMetric Resolver Feedback**

Parameter	Symbol	Units	SM231A	SM232A	SM233B	N0701 or N0341		N0702 or N0342		N0703 or N0343		N0704 or N0344	
			A	A	B	D	F	E	F	F	G	F	G
Winding Selection													
Stall Torque Continuous <sup>1</sup>	T <sub>cs</sub>	lb-in/oz-in	3.5/56	6.7/107	10.2/163	6.4/102		11.9/190		18.0/288		22.2/355	
Stall Current Continuous <sup>1,2</sup>	I <sub>cs</sub>	amperes-rms	2.0	2.0	3.9	2.65	4.14	3.05	4.24	4.17	5.79	4.3	5.96
Rated Speed	w <sub>r</sub>	rpm	7,500	4,250	76,000	7,500	7,500	6,480	7,500	5,850	7,500	4,900	7,000
Peak Torque <sup>1,6</sup>	T <sub>pk</sub>	lb-in/oz-in	17.5/280	33.4/535	50.9/815	19.2		35.6		54.0		66.6	
Peak Current, rms <sup>1,6</sup>	I <sub>pk</sub>	amperes	10	10	19.5	7.9	12.4	9.1	12.7	12.5	17.4	12.9	17.9
Torque @ Rated Speed <sup>1</sup>	T <sub>c</sub>	lb-in/oz-in	2.8/46	6.0/96	9/145	5.8	5.8	9.4	10.4	14.5	15.4	17.5	17.5
Rated Power–Output Shaft <sup>1</sup>	P <sub>o</sub>	watts	250	302	643	510	515	718	919	1,004	1,367	1,014	1,450
Voltage Constant <sup>3,4</sup>	K <sub>v</sub>	volts/radian/sec	0.161	0.31	0.242	0.221	0.14	0.353	0.253	0.392	0.282	0.468	0.338
Voltage Constant <sup>3,4</sup>	K <sub>e</sub>	volts/KRPM	16.86	32.45	25.33	23.11	14.67	36.97	26.52	40.99	29.54	49.02	35.36
Torque Constant <sup>3,4,7</sup>	K <sub>t</sub>	oz-in/amp rms	27.82	53.54	41.76	38.88	24.8	62.24	44.8	69.12	49.76	82.72	59.68
Resistance <sup>3</sup>	R	ohms	5.22	7.5	2.58	5.52	2.27	5.22	2.7	3.36	1.74	3.47	1.80
Inductance <sup>5</sup>	L	millihenries	1.64	2.9	1.06	12.98	5.23	15.86	8.16	12.13	6.30	14.50	7.55
Thermal Resistance <sup>1</sup>	R <sub>th</sub>	°C/watt	2.23	1.58	1.26	1.44		1.15		0.96		0.87	
Motor Constant	Km	oz-in/√watts	9.97	15.99	21.25	13.28	16.48	27.2	27.2	37.76	37.76	44.32	44.48
Viscous Damping	B	oz-in/Krpm	0.565	0.525	0.459	0.701		0.800		0.90		1.00	
Torque/Static Friction	T <sub>f</sub>	oz-in	1.2	2.0	2.25	1.4		2.1		2.8		3.5	
Thermal Time Constant	τ <sub>th</sub>	minutes	30	35	40	45		45		45		45	
Electrical Time Constant	τ <sub>e</sub>	milliseconds	0.31	0.3	0.41	2.35		3.03		3.61		4.19	
Mechanical Time Constant	τ <sub>m</sub>	milliseconds	13.7	14.5	7.0	1.6		0.88		0.62		0.56	
Rotor Inertia	J	lb-in-sec <sup>2</sup>	0.00048	0.00084	0.00119	0.000128		0.000196		0.000262		0.000329	
Weight	#	pounds	2.6	3.5	4.4	3.54		4.53		6.04		7.28	
Winding Class			H	H	H	H		H		H		H	

**92 mm NeoMetric Resolver Feedback**

Parameter	Symbol	Units	N0921		N0922		N0923		N0924	
			F	G	G	J	H	K	J	K
Winding Selection										
Stall Torque Continuous <sup>1</sup>	T <sub>cs</sub>	lb-in	17.7		34.3		46.6		62.5	
Stall Current Continuous <sup>1,2</sup>	I <sub>cs</sub>	amperes-rms	3.77	5.22	5.60	8.67	7.89	13.85	8.64	12.07
Rated Speed	w <sub>r</sub>	rpm	5700	7500	4375	6975	4350	7500	3325	4825
Peak Torque <sup>1</sup>	T <sub>pk</sub>	lb-in	53		103		140		188	
Peak Current, rms <sup>1,6</sup>	I <sub>pk</sub>	amperes	11.3	15.7	16.8	26	23.7	41.6	25.9	36.2
Torque @ Rated Speed <sup>1</sup>	T <sub>c</sub>	lb-in	14.0	14.7	27.0	27.0	36.2	36.3	49	47.7
Rated Power–Output Shaft <sup>1</sup>	P <sub>o</sub>	watts	946	1305	1397	2231	1864	3222	1930	2731
Voltage Constant <sup>3,4</sup>	K <sub>v</sub>	volts/radian/sec	0.427	0.309	0.556	0.360	0.540	0.305	0.657	0.47
Voltage Constant <sup>3,4</sup>	K <sub>e</sub>	volts/KRPM	44.66	32.27	58.18	37.69	56.54	31.96	68.83	49.17
Torque Constant <sup>3,4</sup>	K <sub>t</sub>	lb-in/amp rms	4.71	3.41	6.13	3.97	5.96	3.37	7.25	5.18
Resistance <sup>3</sup>	R	ohms	3.72	1.94	2.32	0.96	1.28	0.42	1.22	0.62
Inductance <sup>5</sup>	L	millihenries	17.11	8.99	14.72	6.18	14.95	4.78	20.60	10.51
Thermal Resistance <sup>1</sup>	R <sub>th</sub>	°C/watt	1.06		0.77		0.70		0.62	
Motor Constant	Km	lb-in/√watts	1.96	2.45	4.03	4.04	5.26	5.22	6.58	6.57
Viscous Damping	B	lb-in/Krpm	0.075		0.087		0.100		0.1125	
Torque-Static Friction	T <sub>f</sub>	oz-in	4		6		8		10	
Thermal Time Constant	τ <sub>th</sub>	minutes	60		60		60		60	
Electrical Time Constant	τ <sub>e</sub>	milliseconds	4.6		6.4		11.5		16.9	
Mechanical Time Constant	τ <sub>m</sub>	milliseconds	1.13		0.64		0.5		0.41	
Rotor Inertia	J	lb-in-sec <sup>2</sup>	0.000532		0.000792		0.00106		0.00132	
Weight	#	pounds	8.1		11.7		15.1		18	
Winding Class			H		H		H		H	

<sup>1</sup> @ 25°C ambient with 10 x 10 x 0.25 in. mounting plate, 150°C winding temperature. At 40°C ambient, derate phase currents and torques by 12%.

<sup>2</sup> RMS current through a single motor phase of a sinusoidally driven motor.

<sup>3</sup> ±10% line-to-line

<sup>4</sup> Peak value

<sup>5</sup> ±30%, line-to-line, inductance bridge measurement @ 1 kHz

<sup>6</sup> Peak current for 2 second maximum with initial winding temperature of 40°C

<sup>7</sup> Effective torque constant when applied with a sinusoidal amplifier.

All specifications are subject to engineering change.

**B Servo Systems**

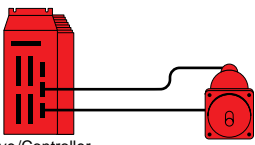

Drive/Controller

# Motor Dimensions

( ) denotes millimeters

## SM231A, SM232A, SM233B

### Size 70 Brushless Servo Motor Dimensions N0701, N0702, N0703, N0704

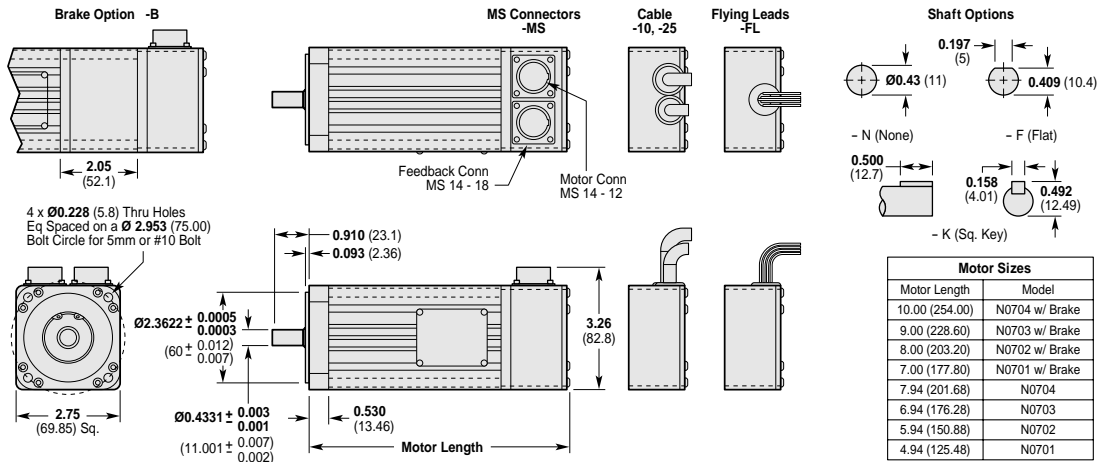

### Size 92 Brushless Servo Motor Dimensions N0921, N0922, N0923, N0924

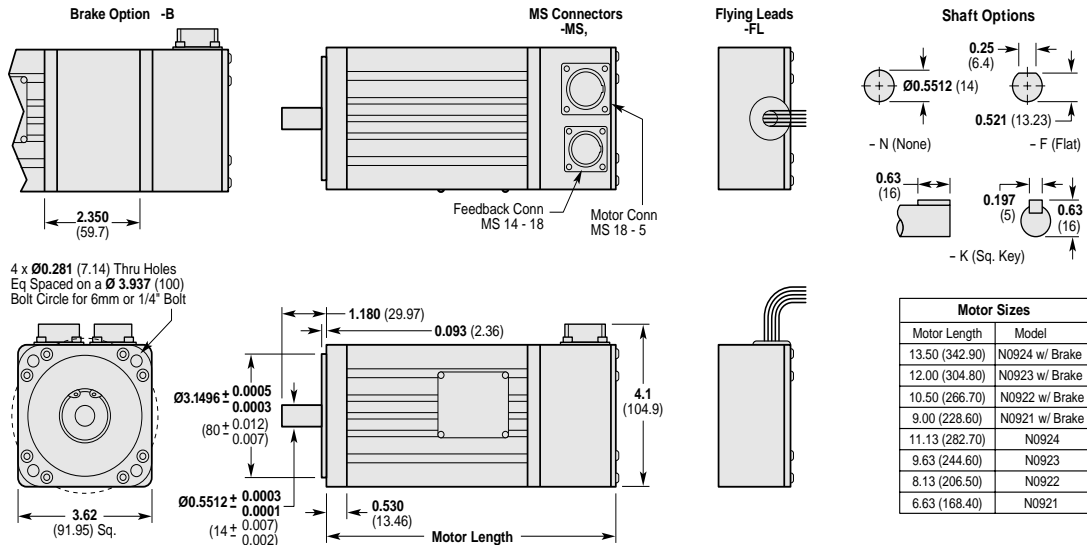

**Speed/Torque Curves**

Note: Parker recommends using SM, 70 mm and 92 mm NeoMetric motors whenever possible for new applications.

The following APEX Series motors are available for existing applications and higher torque requirements.

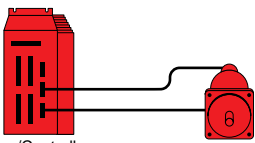

Drive/Controller

## APEX Motor Only Technical Data

		APEX602	APEX603	APEX604	APEX605	APEX606
Continuous Stall Torque @ 40° ambient	lb-in	13.9	21.6	20	22	40
	oz-in	222	346	315	346	634
	Nm	1.57	2.44	2.22	2.44	4.48
Peak Torque	lb-in	39.4	65.4	56	68	122
	oz-in	630	1,046	899	1,085	1,957
	Nm	4.45	7.38	6.35	7.66	13.82
Rated Power	hp	1.5	1.3	2.0	2.0	2.1
	k Watts	1.12	1.0	1.5	1.5	1.6
Rated Speed	rpm	7,500	3,800	7,500	6,200	3,600
	rps	125	63	125	103	60
Rated Current	A (rms)	4.2	3.0	6.0	5	5.3
Peak Current	A (rms)	12.6	9.6	18.0	16.6	17.2
Rotor Inertia	oz-in <sup>2</sup> (mass)	2.52	4.02	4.18	5.43	9.44
	oz-in-sec <sup>2</sup>	0.006	0.01	0.01	0.01	0.02
	kg m <sup>2</sup> x 10 <sup>-6</sup>	46.1	99.6	76.5	99.6	172.9
Motor Weight	lbs	7.0	9.0	8.5	10.0	13.4
	kg	3.2	4.1	3.9	4.5	6.1
Recommended APEX Drive		<b>APEX10 or APEX6151</b>		<b>APEX20 or APEX6152</b>		

		APEX610	APEX620	APEX630	APEX635	APEX640
Continuous Stall Torque @ 40° ambient	lb-in	58	116	164	154	274
	oz-in	922	1,862	2,630	2,458	4,378
	Nm	6.51	13.15	18.57	17.36	30.92
Peak Torque	lb-in	164	331	468	438	779
	oz-in	2,630	5,299	7,488	7,008	12,461
	Nm	18.6	37.4	52.9	49.5	88.0
Rated Power	hp	4.5	6.0	5.7	6.1	6.3
	k Watts	3.3	4.5	4.3	4.5	4.7
Rated Speed	rpm	7,000	3,700	2,500	3,000	1,600
	rps	117	62	42	50	27
Rated Current	A (rms)	14	14	14	14	14
Peak Current	A (rms)	45	45	45	45	45
Rotor Inertia	oz-in <sup>2</sup> (mass)	13.72	35.87	50.79	56.1	111.0
	oz-in-sec <sup>2</sup>	0.04	0.09	0.13	0.15	0.29
	kg m <sup>2</sup> x 10 <sup>-6</sup>	251.2	656	929	1,028	2,034
Motor Weight	lbs	16.4	29.0	32.0	37	51.0
	kg	7.4	13.2	14.5	16.8	23.2
Recommended APEX Drive		<b>APEX40 or APEX6154</b>				

\*These are Compumotor stock motors. Please contact Compumotor for alternative motor windings.

**APEX Motor Dimensions**

(—) denotes millimeters

**APEX602, APEX604**

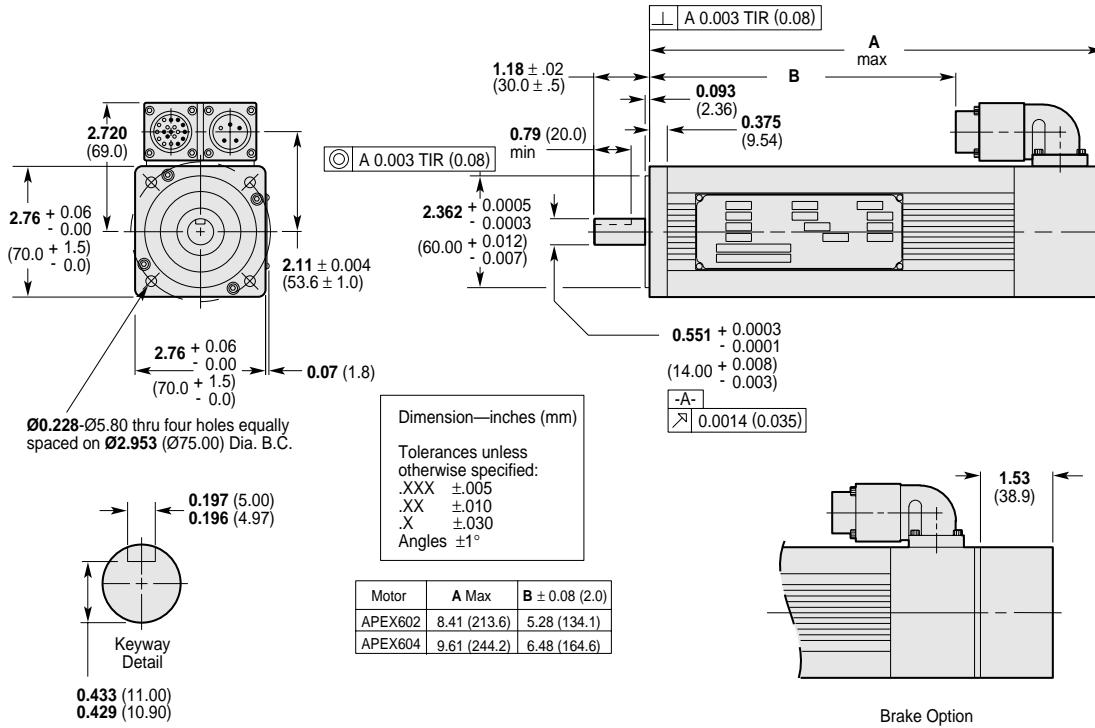

**APEX603, 605, 606, 610**

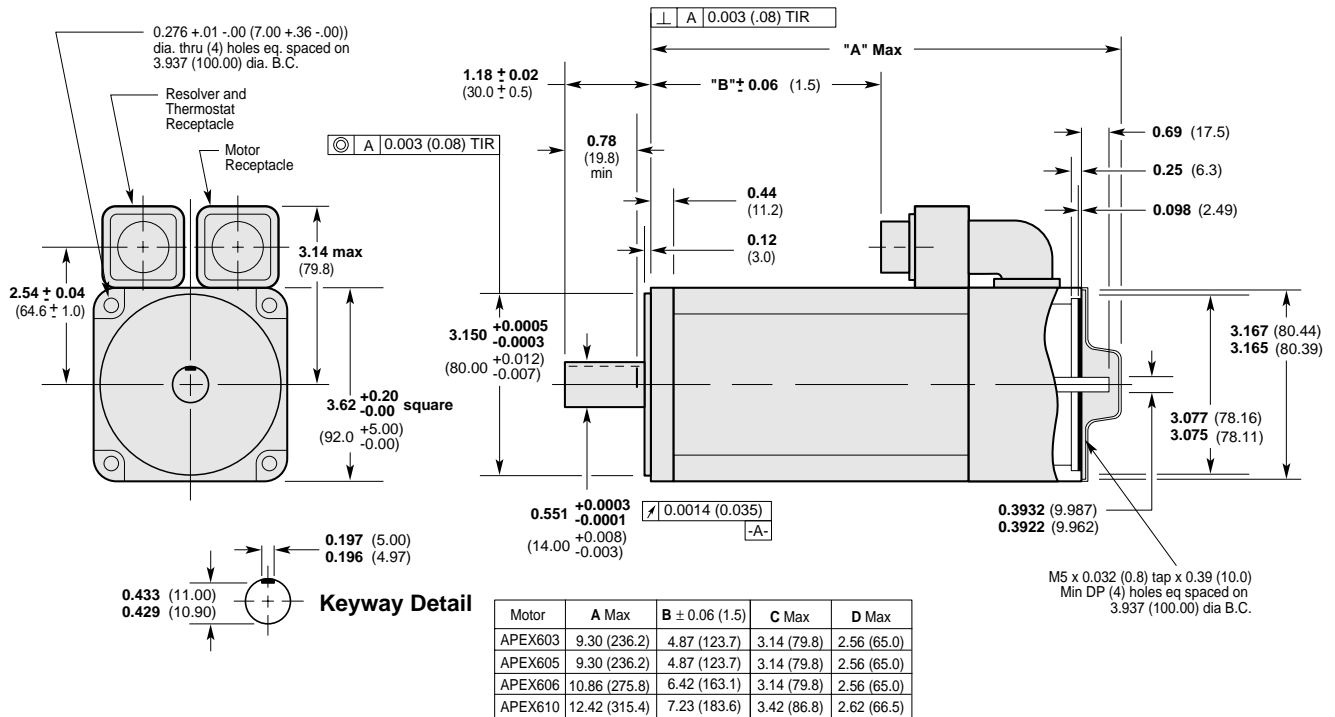

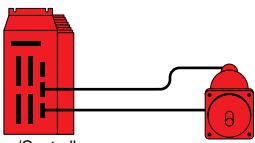

Drive/Controller

## APEX Motor Dimensions

(—) denotes millimeters

### APEX620, 630

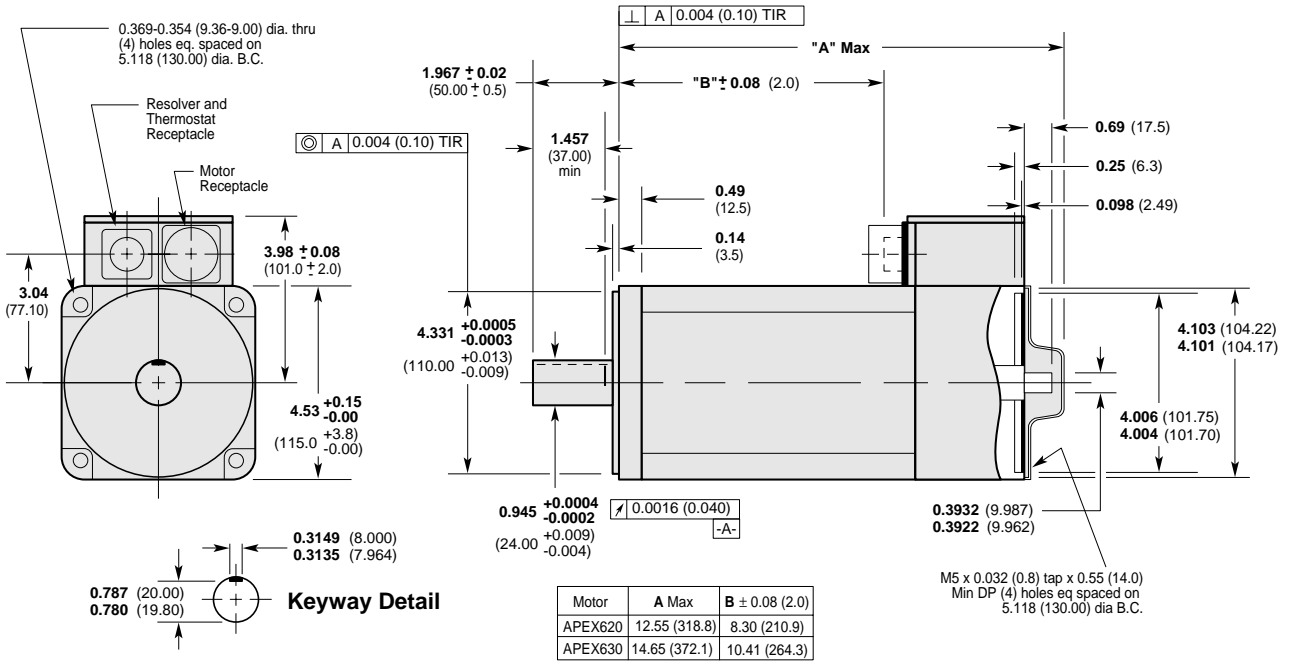

### APEX635, 640

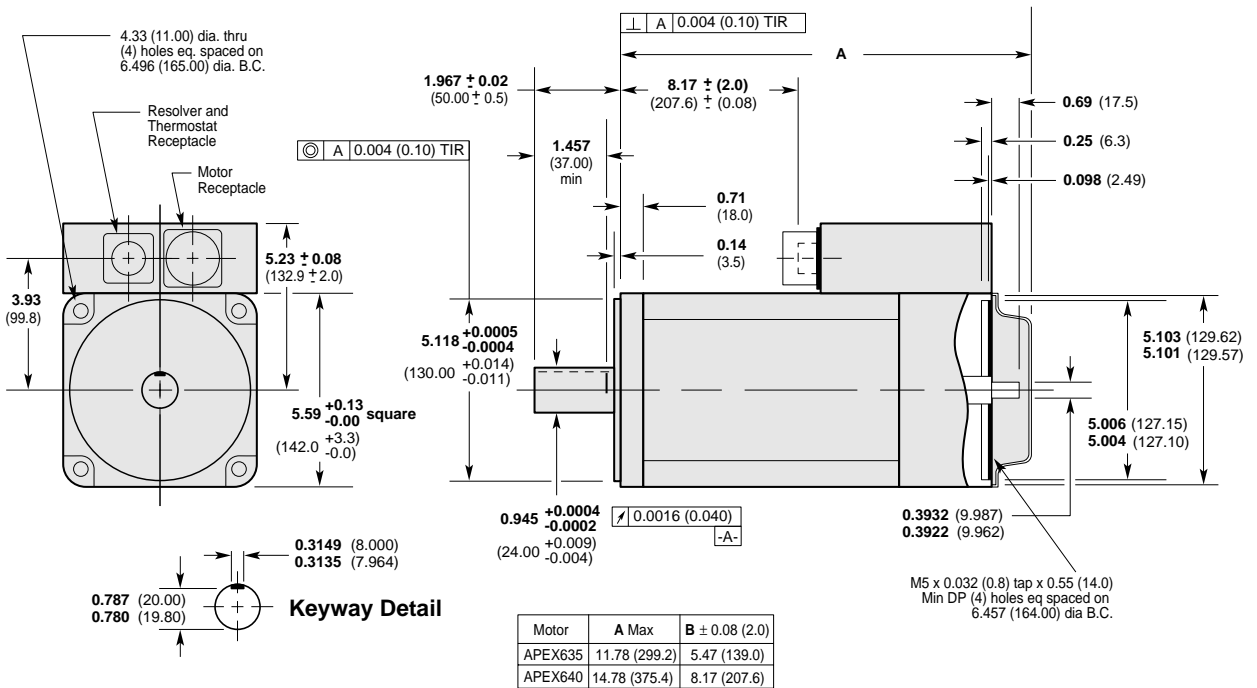

**APEX10, APEX20 and APEX40 Connections**

**Control Connections**

**13-Pin Removable Connector**

Pin No.	Type	Signal
1	Input	Reset
2	Gnd	Gnd
3	Input	Velocity Integrator Enable
4	Input	Enable
5	Output	Fault
6	Gnd	Gnd
7	Input	Command+
8	Input	Command-
9	Output	Tach out
10	Gnd	Gnd
11	Output	+15V
12	Gnd	Gnd
13	Output	-15V

**Power Connections**

**7-Pin High Power Removable Connector**

Pin No.	Type	Signal	APEX20/40	APEX10
1	Input	Line 1	Line 1	Line 1
2	Input	Line 2	Line 2	Line 2
3	Input	Line 3	Earth	Earth
4	Input	Earth	Earth	Earth
5	Input	Earth	Control L1	Control L1
6	Input	Control L1	Control L2	Control L2
7	Input	Control L2		

**Resolver Connections**

**13-Pin Removable Connector**

Pin No.	Type	Signal
1	Input	Shield
2	Input	Stator 3
3	Input	Stator 1
4	Input	Stator 2
5	Input	Stator 4
6	Output	Rotor 1
7	Output	Rotor 2
8	Input	Motor Temp+
9	Input	Motor Temp-
10	Output	Fault Relay+
11	Output	Fault Relay-
12	Input	Feedback+
13	Input	Feedback-

**Motor Connector**

**8-Pin Screw Terminal**

Pin No.	Signal
1	V Bus +
2	Regen Resistor
3	V Bus -
4	Phase A
5	Phase B
6	Phase C
7	Motor Ground
8	Shield

**Encoder Connections**

**7-Pin Removable Connector**

Pin No.	Type	Signal
1	Output	CHA+
2	Output	CHA-
3	Output	CHB+
4	Output	CHB-
5	Output	CHZ+
6	Output	CHZ-
7	Output	Gnd

**Ordering Information**

Model No.	Description	UL and CE (LVD)
-----------	-------------	-----------------

**Drive:**

APEX10	10 Amp analog servo drive
APEX20	20 Amp analog servo drive
APEX40	40 Amp analog servo drive

**Motors:**

SM231AR-NMSN	Size 23 brushless motor with resolver
SM232AR-NMSN	Size 23 brushless motor with resolver
SM233BR-NMSN	Size 23 brushless motor with resolver
N0701DR-NMSN	Size 70 mm brushless motor with resolver
N0701FR-NMSN	Size 70 mm brushless motor with resolver
N0702ER-NMSN	Size 70 mm brushless motor with resolver
N0702FR-NMSN	Size 70 mm brushless motor with resolver
N0703FR-NMSN	Size 70 mm brushless motor with resolver
N0703GR-NMSN	Size 70 mm brushless motor with resolver
N0704FR-NMSN	Size 70 mm brushless motor with resolver
N0704GR-NMSN	Size 70 mm brushless motor with resolver
N0921FR-NMSN	Size 92 mm brushless motor with resolver
N0921GR-NMSN	Size 92 mm brushless motor with resolver
N0922GR-NMSN	Size 92 mm brushless motor with resolver
N0922JR-NMSN	Size 92 mm brushless motor with resolver
N0923HR-NMSN	Size 92 mm brushless motor with resolver
N0923KR-NMSN	Size 92 mm brushless motor with resolver
N0924JR-NMSN	Size 92 mm brushless motor with resolver
N0924KR-NMSN	Size 92 mm brushless motor with resolver

**Motor-to-drive cables:**

71-014675-10	SM-231A, -232A, -233B MS motor (10' cable)
71-014675-25	SM-231A, -232A, -233B MS motor (25' cable)
71-015531-10	70 mm, MS 10-foot motor cable
71-015531-25	70 mm, MS 25-foot motor cable
71-015532-10	92 mm, MS 10-foot motor cable
71-015532-25	92 mm, MS 25-foot motor cable
71-013863-XX	APEX602, 603, 604, 605, 606 motor cable
71-013864-XX	APEX610, 620, 630 motor cable
71-013865-XX	APEX635, 640 motor cable (XX can be 25', 50' or 100')

**Resolver-to-drive cable:**

71-015019-10	SM-231A, -232A, -233B resolver (10')
71-015019-25	SM-231A, -232A, -233B resolver (25')
71-015019-10	70 mm and 92 mm MS 10' resolver cable
71-015019-25	70 mm and 92 mm MS 25' resolver cable
71-013862-XX	Resolver-to-drive cable for APEX600 Series motors (XX can be 25', 50' or 100').

Cables for SM size 23 motors NeoMetric motors are available as a set. These sets consist of 1 motor cable and 1 resolver cable. Standard lengths are 10' and 25'. Please consult factory for options on cable lengths and motor shaft modifications for all SM and NeoMetric Series motors.

**Cable Part No.:**

23RS Cable-10	1 set of 10' cables for SM size 23 motor
23RS Cable-25	1 set of 25' cables for SM size 23 motor
70RS Cable-10	1 set of 10' cables for NeoMetric size 70 mm motor
70RS Cable-25	1 set of 25' cables for NeoMetric size 70 mm motor
92RS Cable-10	1 set of 10' cables for NeoMetric size 92 mm motor
92RS Cable-25	1 set of 25' cables for NeoMetric size 92 mm motor

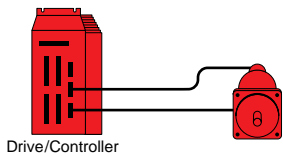

### Model APEX6151, APEX6152 and APEX6154 Connections

#### External Encoder

9-Pin Screw Terminal Pin No.	Signal
1	Shield
2	ISO Ground
3	Z- Channel
4	Z+ Channel
5	B- Channel
6	B+ Channel
7	A- Channel
8	A+ Channel
9	+5VDC (out)

#### Auxiliary

11-Pin Screw Terminal Pin No.	Signal
1	Reserved
2	Reserved
3	Trigger A
4	Trigger B
5	Output -A
6	ISO Ground
7	+5VDC (out)
8	Output Pull-Up
9	Input Pull-Up
10	Auxiliary Pull-Up
11	V___ I/O

### Programmable I/O Pin Outs

#### 50-Pin Header

#### Pin No. I/O Connector

1	Input #16	27	Input #7
3	Input #15	29	Input #6
5	Input #14	31	Input #5
7	Input #13	33	Output #4
9	Input #12	35	Output #3
11	Input #11	37	Output #2
13	Input #10	39	Output #1
15	Input #9	41	Input #4
17	Output #8	43	Input #3
19	Output #7	45	Input #2
21	Output #6	47	Input #1
23	Output #5	49	+5VDC
25	Input #8		

#### COM 1

3-Pin Screw Terminal Pin No.	Signal
1	Rx
2	Tx
3	ISO Ground

#### COM 2

#### 5-Pin Screw Terminal

Pin No.	Signal	
	RP240	RS485
1	+5V	Rx+
2	ISO GND	Rx-
3	Rx	Tx+
4	Tx	Tx-
5	Shield	ISO GND

#### Power Connections

#### 7-Pin High Power Removable Connector

Pin No.	Type	Signal	
		APEX6152/6154	APEX6151
1	Input	Line 1	Line 1
2	Input	Line 2	Line 2
3	Input	Line 3	Earth
4	Input	Earth	Earth
5	Input	Earth	Earth
6	Input	Control L1	Control L1
7	Input	Control L2	Control L2

#### Limits

#### 4-Pin Screw Terminal

Pin No.	Signal
1	ISO Ground
2	Home
3	Negative
4	Positive

#### Motor Connector

#### 8-Pin Screw Terminal

Pin No.	Signal
1	V Bus +
2	Regen Resistor
3	V Bus -
4	Phase A
5	Phase B
6	Phase C
7	Motor Ground
8	Shield

### Ordering Information

Part No.	Description	and $\text{CE}$ (LVD)
----------	-------------	-----------------------

#### Drives:

APEX6151	10 Amp analog servo drive
APEX6152	20 Amp analog servo drive
APEX6154	40 Amp analog servo drive

#### Motors:

SM231AR-NMSN	Size 23 brushless motor with resolver
SM232AR-NMSN	Size 23 brushless motor with resolver
SM233BR-NMSN	Size 23 brushless motor with resolver
N0701DR-NMSN	Size 70 mm brushless motor with resolver
N0701FR-NMSN	Size 70 mm brushless motor with resolver
N0702ER-NMSN	Size 70 mm brushless motor with resolver
N0702FR-NMSN	Size 70 mm brushless motor with resolver
N0703FR-NMSN	Size 70 mm brushless motor with resolver
N0703GR-NMSN	Size 70 mm brushless motor with resolver
N0704FR-NMSN	Size 70 mm brushless motor with resolver
N0704GR-NMSN	Size 70 mm brushless motor with resolver
N0921FR-NMSN	Size 92 mm brushless motor with resolver
N0921GR-NMSN	Size 92 mm brushless motor with resolver
N0922GR-NMSN	Size 92 mm brushless motor with resolver
N0922JR-NMSN	Size 92 mm brushless motor with resolver
N0923HR-NMSN	Size 92 mm brushless motor with resolver
N0923KR-NMSN	Size 92 mm brushless motor with resolver
N0924JR-NMSN	Size 92 mm brushless motor with resolver
N0924KR-NMSN	Size 92 mm brushless motor with resolver

**Ordering Information** (continued)

**Motor-to-drive cables:**

71-014675-10	SM-231A, -232A, -233B MS motor (10 foot)
71-014675-25	SM-231A, -232A, -233B MS motor (25 foot)
71-015531-10	70 mm, MS 10-foot resolver cable
71-015531-25	70 mm, MS 25-foot resolver cable
71-015532-10	92 mm, MS 10-foot resolver cable
71-015532-25	92 mm, MS 25-foot resolver cable
71-013863-XX	APEX602, 603, 604, 605, 606 motor
71-013864-XX	APEX610, 620, 630 motor
71-013865-XX	APEX635, 640 motor (XX can be 25, 50 or 100 feet)

**Resolver-to-drive cable:**

71-015019-10	SM-231A, -232A, -233B resolver (10 foot)
71-015019-25	SM-231A, -232A, -233B resolver (25 foot)
71-015019-10	70 mm and 92 mm MS 10-foot resolver cable
71-015019-25	70 mm and 92 mmMS 25-foot resolver cable
71-013862-XX	Resolver-to-drive cable for APEX600 Series motors (XX can be 25, 50 or 100 feet)

Cables for SM size 23 motors NeoMetric motors are available as a set. These sets consist of 1 motor cable and 1 resolver cable. Standard lengths are 10 ft and 25 ft. Please consult factory for options on cable lengths and motor shaft modifications for all SM and NeoMetric Series motors.

**Cable Part No.:**

23RS Cable-10	1 set of 10-ft cables for SM size 23 motor
23RS Cable-25	1 set of 25-ft cables for SM size 23 motor
70RS Cable-10	1 set of 10-ft cables for NeoMetric size 70 mm motor
70RS Cable-25	1 set of 25-ft cables for NeoMetric size 70 mm motor
92RS Cable-10	1 set of 10-ft cables for NeoMetric size 92 mm motor
92RS Cable-25	1 set of 25-ft cables for NeoMetric size 92 mm motor

**Accessories**

<b>Part No.</b>	<b>Description</b>
VM24S	24V input/output module. See page B138.
RP240	Operator interface. See page B140.
RP240-NEMA4	NEMA rated operator interface. Flat panel mounted. See page B140.
Servo Tuner	Motion Architect's Servo Tuning module. See page B109.
DDE 6000	DDE server for APEX6152 and APEX6154. Includes software disk with instructions. See page B109.
Motion Builder	Graphical icon-based software. See page B109.



**Software information is available on page B109.**

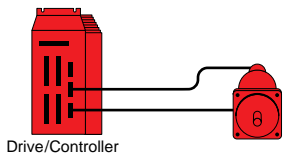

**APEX10 and APEX6151 Dimensions**

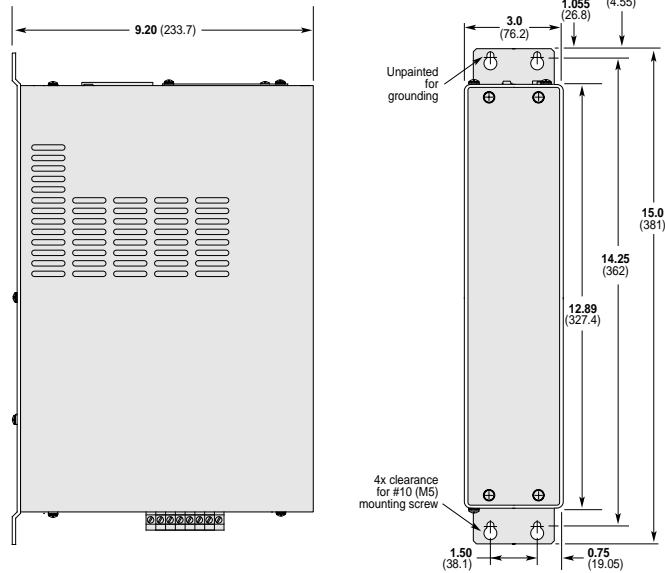

**APEX20 and APEX6152 Dimensions**

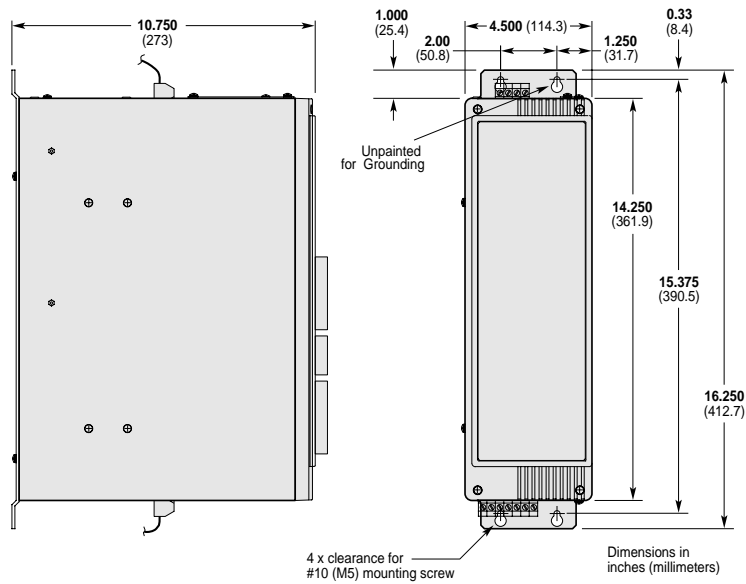

**APEX40 and APEX6154 Dimensions**

